

# terminal connectors

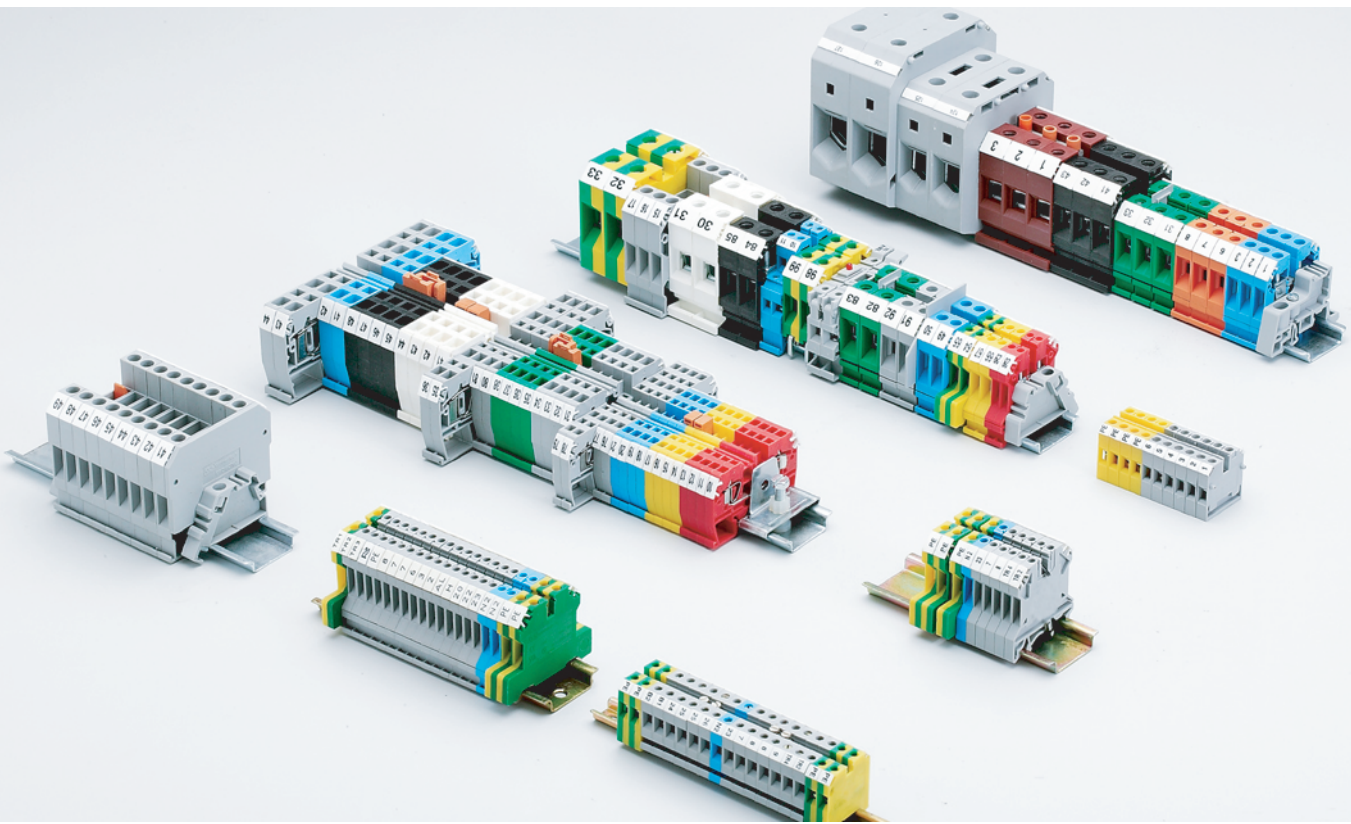

# Index

Contents	Page	Contents	Page
Standard Feed-Through, Screw Clamp Terminals .....	2	Spring Clamp Ground .....	17
Feed-Through, Screw Clamp Terminals for Highly Corrosive and Explosive Environment .....	4	Panel Mount, Neutral/Earth Screw Clamp Busbar Systems .....	18
Standard Feed-Through, Spring Clamp Terminals .....	6	Distribution Blocks .....	19
Multiple Connection, Feed-Through Spring Clamp Terminals .....	7	Safety Fuse Link Terminals .....	21
Multiple Connection, Feed-Through Screw Clamp Terminals .....	9	Disconnect & Test Terminals .....	24
Micro, Feed-Through Terminals .....	10	Tab Connection Terminals .....	26
Double Level, Feed-Through Terminals .....	11	Clip Connection Terminals .....	27
Offset Double Level, Feed-Through Terminals .....	12	Terminals with Electronic Components .....	28
Triple Level, Feed-Through Terminals .....	13	Printed Circuit Board Modular Terminals .....	32
Panel Mount Feed-Through Screw Clamp Terminals .....	14	High Current, Feed-Through Screw Clamp Terminals .....	34
Panel Mount Feed-Through Spring Clamp Terminals .....	14	Active Terminal Blocks .....	35
Grounding (Earth) Terminals .....	15	Thermocouple Terminal Blocks .....	37
		Accessories .....	38
		Terminals Details .....	46

## Product Finder

<b>SCRW2.5U</b>	<b>SCRW4U</b>	<b>SCRW6U</b>	<b>SCRW10U</b>	<b>SCRW16U</b>	<b>SCRW25U</b>
					
Page 2	Page 2	Page 2	Page 3	Page 3	Page 3
STANDARD FEED-THROUGH, SCREW CLAMP TERMINALS					
<b>SCRW35U</b>	<b>SCRW2.5UCR</b>	<b>SCRW4UCR</b>	<b>SCRW6UCR</b>	<b>SCRW10UCR</b>	<b>SCRW16UCR</b>
					
Page 3	Page 4	Page 4	Page 4	Page 5	Page 5
FEED-THROUGH, SCREW CLAMP TERMINALS FOR HIGHLY CORROSIVE AND EXPLOSIVE ENVIRONMENT					
<b>SCRW25UCR</b>	<b>SCRW35UCR</b>	<b>CAGE2.5</b>	<b>CAGE4</b>	<b>CAGE6</b>	<b>CAGE2.5 1-2/2-2</b>
					
Page 5	Page 5	Page 6	Page 6	Page 6	Page 7
STANDARD FEED-THROUGH, SPRING CLAMP TERMINALS					
<b>CAGE4 1-2/2-2</b>	<b>CAGE6 1-2/2-2</b>	<b>SCRW4U 1-2/2-2</b>	<b>M4/S</b>	<b>DBL4U</b>	<b>DBL4U(I.S)</b>
					
Page 7	Page 8	Page 9	Page 10	Page 11	Page 11
MULTIPLE CONNECTION, FEED-THROUGH SPRING CLAMP TERMINALS		MULTIPLE CONNECTION, FEED-THROUGH SCREW CLAMP TERMINALS		DOUBLE LEVEL, FEED-THROUGH TERMINALS	
<b>DBLOFF4U</b>	<b>TL2.5U#</b>	<b>TL2.5UH/L</b>	<b>P4</b>	<b>CAGEP2.5</b>	<b>CAGEP2.5 2-2</b>
					
Page 12	Page 13	Page 13	Page 14	Page 14	Page 14
OFFSET DOUBLE LEVEL, FEED-THROUGH TERMINALS		TRIPLE LEVEL, FEED-THROUGH TERMINALS		PANEL MOUNT SCREW CLAMP TERMINALS	
PANEL MOUNT SPRING CLAMP TERMINALS		PANEL MOUNT SCREW CLAMP TERMINALS		PANEL MOUNT SPRING CLAMP TERMINALS	
<b>G4</b>	<b>G10</b>	<b>G35</b>	<b>GM4</b>	<b>CAGEG2.5</b>	<b>CAGEG4</b>
					
Page 15	Page 15	Page 16	Page 16	Page 17	Page 17
GROUNDING (EARTH) TERMINALS				SPRING CLAMP GROUND TERMINALS	

## Product Finder (continued)

<b>CAGEG6</b>  Page 17	<b>GN4, GN16</b>  Page 18 PANEL MOUNT, NEUTRAL/EARTH SCREW CLAMP BUSBAR SYSTEMS	<b>GN35</b>  Page 18	<b>DISBL4</b>  Page 19	<b>DISBL4(1)</b>  Page 19	<b>DISBL6</b>  Page 20
DISTRIBUTION BLOCKS					
<b>DISBL10</b>  Page 20	<b>F4U</b>  Page 21	<b>F4U(L)</b>  Page 21	<b>FDBL4U</b>  Page 22	<b>FDBL4UE</b>  Page 22	<b>FDBL4UE(LR)</b>  Page 22
SAFETY FUSE LINK TERMINALS					
<b>FA4U</b>  Page 22	<b>F6U</b>  Page 23	<b>DISCT6U</b>  Page 24	<b>KN4U</b>  Page 24	<b>DISCTL4U</b>  Page 24	<b>DISCT6US</b>  Page 25
DISCONNECT & TEST TERMINALS					
<b>DISCTL6U</b>  Page 25	<b>DBLDISCTL4U</b>  Page 24	<b>TAB4U</b>  Page 26	<b>SCRW4UTAB</b>  Page 26	<b>SCRW4UCLIP</b>  Page 27	<b>DBL4UCLIP</b>  Page 27
TAB CONNECTION TERMINALS			CLIP TERMINALS BLOCKS		
<b>DBL4UED1/D2/D3</b>  Page 28	<b>DBL4UEDD1/DD2/DD3/DD4</b>  Page 29	<b>DBL4UED4/DD5</b>  Page 29	<b>DBL4UEN1, DBL4UELD3/4/5</b>  Page 30	<b>DBL4UELD1/LD2 DBL4UEL1/L2</b>  Page 31	<b>DBL4U(O)</b>  Page 31
TERMINALS WITH ELECTRONIC COMPONENTS					
<b>PCBM5H/A/V</b>  Page 32-33	<b>PCB5</b>  Page 33	<b>PCB7.5</b>  Page 33	<b>PCBDBL11</b>  Page 33	<b>SCRW50U</b>  Page 34	<b>SCRW95U</b>  Page 34
PRINTED CIRCUIT BOARD MODULAR TERMINALS				HIGH CURRENT, FEED-THROUGH SCREW CLAMP TERMINALS	
<b>DBL4UELA/3LA</b>  Page 35	<b>DBL4UEMOV</b>  Page 36	<b>DBL4UESD/RC/RS</b>  Page 36	<b>TH2.5U</b>  Page 37 THERMOCOUPLE TERMINAL BLOCKS	<b>End Clamps/ Stop</b>  Page 39	<b>Rails</b>  Page 39
ACTIVE TERMINAL BLOCKS			Pre-Assembled Shorting Links		
<b>Mounting Bracket</b>  Page 39	<b>End Plates</b>  Page 40	<b>Partition Plates</b>  Page 41	<b>Shorting Links, Sleeves</b>  Page 41	 Page 41	
<b>Comb Links, Insulated Push-In Shorting Links</b>  Page 41 - 42		<b>Markers &amp; Marker Plotter</b>  Page 43 - 44		<b>Technical Details</b>  Page 45	

## Standard, Feed-Through Screw Clamp Terminals

The "U" Series, universal rail mounting, standard screw clamp, feed through terminals are the most versatile for wire-to-wire connections for control, automation, industrial and power distribution applications. The

terminals mount on DIN 32, DIN 35 and DIN 35-15 rails. A special design feature of the flexible foot enables easy mounting and dismounting from the DIN rail with a screwdriver.

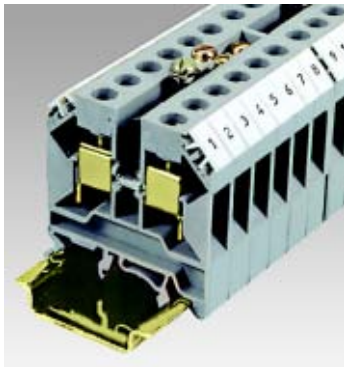

**SCRW2.5U**

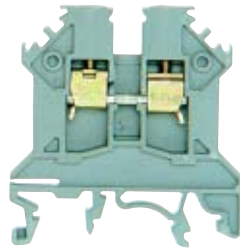

**SCRW4U**

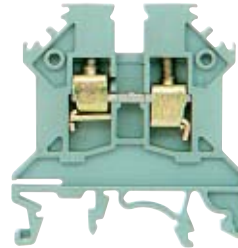

**SCRW6U**









Terminal Pitch	5 mm			6 mm			8 mm		
Height x Width	45 x 43 mm			45 x 43 mm			47 x 43 mm		
Connection Possibility	Stranded Wire	0.5 to 2.5 sq.mm		0.5 to 4 sq.mm		1.5 to 6 sq.mm		1.5 to 10 sq.mm	
	Solid Wire	0.5 to 4 sq.mm		0.5 to 6 sq.mm		1.5 to 10 sq.mm			
Stripping Length	9 mm			9 mm			12 mm		
Insulation Material	Polyamide 6.6			Polyamide 6.6			Polyamide 6.6		
Type of Connection	2 screw clamps and 1 tapped hole for cross connection			2 screw clamps and 1 tapped hole for cross connection			2 screw clamps and 1 tapped hole for cross connection		
Approvals									
Rated Cross Section	22-14 AWG	0.5-2.5sq.mm	22-14 AWG	22-12 AWG	0.5 - 4 sq.mm	22-10 AWG	22-8 AWG	1.5-6 sq.mm	22-8 AWG
Voltage Rating	600 V	750 V	600 V	600 V	750 V	600 V	600 V	750 V	600 V
Current Rating	20 A	24 A	20 A	25 A	32 A	35 A**	50 A	41 A	50 A
Torque	7 lb-in	0.4 Nm	7 lb-in	7 lb-in	0.5 Nm	7 lb-in	9 lb-in	0.8 Nm	14 lb-in
	Type Cat No.	Std. Packing in Nos.	Wt Per unit in Grams	Type Cat No.	Std. Packing in Nos.	Wt Per unit in Grams	Type Cat No.	Std. Packing in Nos.	Wt Per unit in Grams
Terminal Station	SCRW2.5U	100	6	SCRW4U	100	7.6	SCRW6U	100	13
End Plate	EPSCRW2.5U/4U	50	1.7	EPSCRW2.5U/4U	50	1.7	EPSCRW6U/10U	50	2.2
Partition Plate	PPSCRW2.5U/4U	50	2.3	PPSCRW2.5U/4U	50	2.3	PPSCRW6U/10U	50	2.9
Mounting Rail	DIN 32G	50 M	750	DIN 32G	50 M	750	DIN 32G	50 M	750
	DIN 35U	50 M	360	DIN 35U	50 M	360	DIN 35U	50 M	360
	DIN 35-15D	50 M	700	DIN 35-15D	50 M	700	DIN 35-15D	50 M	700
End Clamp	ES1S	50	15.3	ES1S	50	15.3	ES1S	50	15.3
	ES2S	50	15.1	ES2S	50	15.1	ES2S	50	15.1
	ES3S	50	7.0	ES3S	50	7.0	ES3S	50	7.0
	ES2N	50	7.4	ES2N	50	7.4	ES2N	50	7.4
	ES3N	50	4.5	ES3N	50	4.5	ES3N	50	4.5
Pre Assembled Shorting Links	2 way  PASL05/2	10	1.3	2 way  PASL06/2	10	2.2	2 way  PASL08/2	10	3.1
	3 way  PASL05/3	10	1.5	3 way  PASL06/3	10	3.2	3 way  PASL08/3	10	3.5
	4 way  PASL05/4	10	1.7	4 way  PASL06/4	10	3.9	4 way  PASL08/4	10	4.3
	10 way  PASL05/10	10	11	10 way  PASL06/10	10	11.5	10 way  PASL08/10	10	30
Permanent Shorting Link	2 way  PSL05/2	100	0.3	2 way  PSL06/2	100	0.3	2 way  PSL08/2	100	0.5
	3 way  PSL05/3	100	0.4	3 way  PSL06/3	100	0.5	3 way  PSL08/3	100	0.9
	4 way  PSL05/4	100	0.5	4 way  PSL06/4	100	0.7	4 way  PSL08/4	100	1.35
	10 way  PSL05/10	100	1.4	10 way  PSL06/10	100	1.7	10 way  PSL08/10	100	3.25
Short Sleeve for quick Permanent Shorting	SS02	100	1.16	SS02	100	1.16	SS03	100	2.64
Removable Shorting Link	RSL5	100	0.2	RSL6	100	0.25	RSL8	100	0.51
Long Sleeve for quick Temporary Shorting	SL04	100	1.75	SL04	100	1.73	SL02	100	3.69
Comb Link	2 way  CL6/2	100	1.2	2 way  CL6/2	100	1.2			
	3 way  CL6/3	100	1.8	3 way  CL6/3	100	1.8			
	4 way  CL6/4	100	2.4	4 way  CL6/4	100	2.4			
	10 way  CL6/10	50	6.0	10 way  CL6/10	50	6.0			
Marking Tags (K Type)	KM/5	100	0.07	KM/6	100	0.1	KM/8	100	0.12

\* 10 way breakable shorting link.

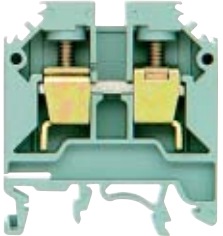
\*\* 40A with 2 Nos of 12AWG wire, 35A with 1No of 10 AWG wire

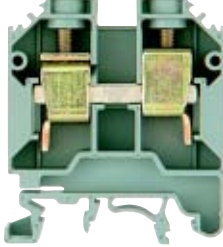
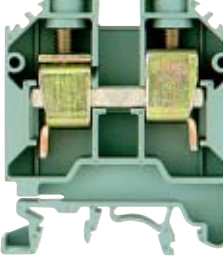
The terminals are suitable for wire size of 0.5 to 35 sq.mm. (22 - 1/0 AWG) and accept international 'K' type markers.

Wide range of accessories further improve the flexibility for wider applications. Shorting links and sleeves can be used for cross connections.

SCRW10U			SCRW16U			SCRW25U			SCRW35U		
											
10 mm			12 mm			12 mm			15 mm		
47 x 43 mm			47 x 43 mm			56 x 49.5 mm			58 x 52.5 mm		
1.5 to 10 sq.mm 1.5 to 16 sq.mm			2.5 to 16 sq.mm 2.5 to 25 sq.mm			6 to 25 sq.mm 6 to 35 sq.mm			10 to 35 sq.mm 10 to 50 sq.mm		
12 mm			16 mm			18 mm			18 mm		
Polyamide 6.6			Polyamide 6.6			Polyamide 6.6			Polyamide 6.6		
2 screw clamps and 1 tapped hole for cross connection			2 screw clamps and 1 tapped hole for cross connection			2 screw clamps and 1 tapped hole for cross connection			2 screw clamps and 1 tapped hole for cross connection		
											
15-7 AWG 1.5-10 sq.mm 16-6 AWG			14-6 AWG 2.5-16 sq.mm 14-6 AWG			9-3 AWG 6-25 sq.mm 14-2 AWG			7-2 AWG 10-35sq.mm 18-1/0 AWG		
600 V 750 V 600 V			600 V 750 V 600 V			600 V 750 V 600 V			600 V 750 V 600 V		
65 A 57 A 65 A			70 A 76 A 70 A			115 A 101 A 115 A			145 A 125 A 145 A		
14 lb-in 1.2 Nm 14 lb-in			14 lb-in 2.0 Nm 14 lb-in			14 lb-in 2.0 Nm 14 lb-in			25 lb-in 2.5 Nm 25 lb-in		
<b>Type Cat No.</b>	<b>Std. Packing in Nos.</b>	<b>Wt Per unit in Grams</b>	<b>Type Cat No.</b>	<b>Std. Packing in Nos.</b>	<b>Wt Per unit in Grams</b>	<b>Type Cat No.</b>	<b>Std. Packing in Nos.</b>	<b>Wt Per unit in Grams</b>	<b>Type Cat No.</b>	<b>Std. Packing in Nos.</b>	<b>Wt Per unit in Grams</b>
SCRW10U	100	17.5	SCRW16U	50	25	SCRW25U	50	35	SCRW35U	50	49
EPSCRW6U/10U	50	2.2				EPSCRW25U	50	2.4	EPSCRW35U	50	3.6
PPSCRW6U/10U	50	2.9	SPSCRW16U	100		PPSCRW25U	50	4.2	PPSCRW35U	50	4.9
DIN 32G 50 M	750		DIN 32G 50 M	760		DIN 32G 50 M	750		DIN 32G 50 M	750	
DIN 35U 50 M	360		DIN 35U 50 M	360		DIN 35U 50 M	360		DIN 35U 50 M	360	
DIN 35-15D 50 M	700		DIN 35-15D 50 M	700		DIN 35-15D 50 M	700		DIN 35-15D 50 M	700	
ES1S 50	15.3		ES1S 50			ES1S 50	15.3		ES1S 50	15.3	
ES2S 50	15.1		ES2S 50			ES2S 50	15.1		ES2S 50	15.1	
ES3S 50	7.0		ES2N 50	7.4		ES3S 50	7.0		ES3S 50	7.0	
ES2N 50	7.4		ES3N 50	4.5		ES2N 50	7.4		ES2N 50	7.4	
ES3N 50	4.5		ES3S 50			ES3N 50	4.5		ES3N 50	4.5	
PASL10/2 10	6.4		PASL12/2A 100	6.4		PASL12/2 10	11.6		PASL15/2 10	12.2	
PASL10/3 10	9.6		PASL12/3A 50	9.6		PASL12/3 10	17.8		PASL15/3 10	18.8	
PASL10/4 10	13		PASL12/4A 50	13		PASL12/4 10	24.1		PASL15/4 10	25.5	
PASL10/10 10	32.4		PASL12/10A 10	32.4		PASL12/10 10	60.4		PASL15/10 10	63.4	
PSL10/2 100	0.95		PSL12/2A 100			PSL12/2 100	1.5		PSL15/2 100	1.9	
PSL10/3 100	1.5		PSL12/3A 100			PSL12/3 100	2.5		PSL15/3 100	3.5	
PSL10/4 100	2.2		PSL12/4A 100			PSL12/4 100	3.7		PSL15/4 100	5	
PSL10/10 100	5.4		PSL12/10A 10			PSL12/10 100	8.9		PSL15/10 100	11.9	
SS03 100	2.64		SS05 50	2.64		SS04 50	5.15		SS04 50	5.15	
RSL10 100	0.75		RSL12 100	0.75		RSL12A 100	1.2		RSL15 100	1.7	
SL02 100	3.7		SL05 50	3.7		SL03 50	7.39		SL03 50	7.39	
KM/10 100	0.16		KM/12 100 KM/9F 10	0.16		KM/12 100	0.2		KM/15 100	0.24	

# Feed-Through Screw Clamp Terminals for Highly Corrosive Environment

The "U" Series, universal rail mounting terminal blocks for highly corrosive environment comply to the international standards, with carefully selected insulating material for shell and copper/copper alloy with

appropriate surface protection for fail-proof clamping parts. With right materials, process and surface protection treatment; seasoned cracking is eliminated. The terminal blocks comply to 'Corrosion Cracking Test'

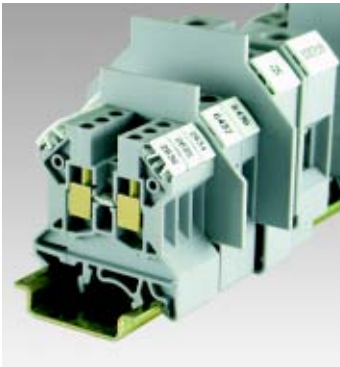

**SCRW2.5UCR**





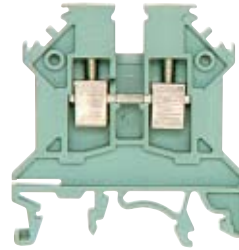





**SCRW4UCR**

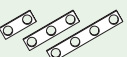

**SCRW6UCR**



Terminal Pitch	5 mm			6 mm			8 mm			
	45 x 43 mm			45 x 43 mm			47 x 43 mm			
Connection Possibility	Stranded Wire	0.5 to 2.5 sq.mm 0.5 to 4 sq.mm			0.5 to 4 sq.mm 0.5 to 6 sq.mm			1.5 to 6 sq.mm 1.5 to 10 sq.mm		
		9 mm			9 mm			12 mm		
Insulation Material	Polyamide 6.6			Polyamide 6.6			Polyamide 6.6			
Type of Connection	2 screw clamps and 1 tapped hole for cross connection			2 screw clamps and 1 tapped hole for cross connection			2 screw clamps and 1 tapped hole for cross connection			
Approvals*	CSA Standard	CE	UL Standard	CSA Standard	CE	UL Standard	CSA Standard	CE	UL Standard	
	Rated Cross Section	22-14 AWG	0.5-2.5sq.mm	22-14 AWG	22-12 AWG	0.5 - 4 sq.mm	22-12 AWG	22-8 AWG	1.5-6 sq.mm	22-8 AWG
Voltage Rating	600 V	750 V	600 V	600 V	750 V	600 V	600 V	750 V	600 V	
Current Rating	20 A	24 A	20 A	25 A	32 A	25 A	50 A	41 A	50 A	
Torque	7 lb-in	0.4 Nm	7 lb-in	7 lb-in	0.5 Nm	7 lb-in	9 lb-in	0.8 Nm	14 lb-in	
	Type Cat No.	Std. Packing in Nos.	Wt Per unit in Grams	Type Cat No.	Std. Packing in Nos.	Wt Per unit in Grams	Type Cat No.	Std. Packing in Nos.	Wt Per unit in Grams	
Terminal Station	SCRW2.5UCR	100	6	SCRW4UCR	100	7.6	SCRW6UCR	100	13	
End Plate	 EPSCRW2.5U/4U	50	1.7	EPSCRW2.5U/4U	50	1.7	EPSCRW6U/10U	50	2.2	
Partition Plate	 PPSCRW2.5U/4U	50	2.3	PPSCRW2.5U/4U	50	2.3	PPSCRW6U/10U	50	2.9	
Mounting Rail	 DIN 32G	50 M	750	DIN 32G	50 M	750	DIN 32G	50 M	750	
	DIN 35U	50 M	360	DIN 35U	50 M	360	DIN 35U	50 M	360	
	DIN 35-15D	50 M	700	DIN 35-15D	50 M	700	DIN 35-15D	50 M	700	
End Clamp	 ES1S	50	15.3	ES1S	50	15.3	ES1S	50	15.3	
	ES2S	50	15.1	ES2S	50	15.1	ES2S	50	15.1	
	ES3S	50	7.0	ES3S	50	7.0	ES3S	50	7.0	
	ES2N	50	7.4	ES2N	50	7.4	ES2N	50	7.4	
	ES3N	50	4.5	ES3N	50	4.5	ES3N	50	4.5	
Pre Assembled Shorting Links	2 way  PASL05/2	10	1.3	PASL06/2	10	2.2	PASL08/2	10	3.1	
	3 way	PASL05/3	10	1.5	PASL06/3	10	3.2	PASL08/3	10	3.5
	4 way	PASL05/4	10	1.7	PASL06/4	10	3.9	PASL08/4	10	4.3
	10 way	PASL05/10	10	11	PASL06/10	10	11.5	PASL08/10	10	30
	Permanent Shorting Link	2 way  PSL05/2	100	0.3	PSL06/2	100	0.3	PSL08/2	100	0.5
3 way		PSL05/3	100	0.4	PSL06/3	100	0.5	PSL08/3	100	0.9
4 way		PSL05/4	100	0.5	PSL06/4	100	0.7	PSL08/4	100	1.35
10 way		PSL05/10	100	1.4	*PSL06/10	100	1.7	PSL08/10	100	3.25
Short Sleeve for quick Permanent Shorting		 SS02	100	1.16	SS02	100	1.16	SS03	100	2.64
Removable Shorting Link	 RSL5	100	0.2	RSL6	100	0.25	RSL8	100	0.51	
Long Sleeve for quick Temporary Shorting	 SL04	100	1.75	SL04	100	1.73	SL02	100	3.69	
Comb Link	2 way			CL6/2	100	1.2				
	3 way			CL6/3	100	1.8				
	4 way			CL6/4	100	2.4				
	10 way			CL6/10	50	6.0				
Marking Tags (K Type)	 KM/5	100	0.07	KM/6	100	0.1	KM/8	100	0.12	

\* Proposed ratings as per CSA and UL standards.

\* 10 way breakable shorting link.

as per **CSA C 22.2 No.158 standard**. These terminals ensure superior performance in corrosive conditions, compared to most other components used in the cabinets, switchboards and control boxes.

**SCRW10UCR**

**SCRW16UCR**

**SCRW25UCR**

**SCRW35UCR**

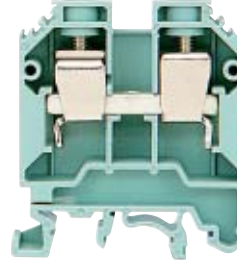
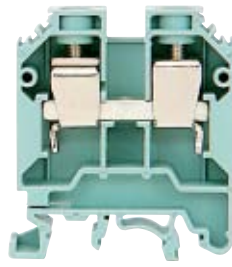

10 mm			12 mm			12 mm			15 mm		
47 x 43 mm			47 x 43 mm			56 x 49.5 mm			58 x 52.5 mm		
1.5 to 10 sq.mm 1.5 to 16 sq.mm			2.5 to 16 sq.mm 2.5 to 25 sq.mm			6 to 25 sq.mm 6 to 35 sq.mm			10 to 35 sq.mm 10 to 50 sq.mm		
12 mm			16 mm			18 mm			18 mm		
Polyamide 6.6			Polyamide 6.6			Polyamide 6.6			Polyamide 6.6		
2 screw clamps and 1 tapped hole for cross connection			2 screw clamps and 1 tapped hole for cross connection			2 screw clamps and 1 tapped hole for cross connection			2 screw clamps and 1 tapped hole for cross connection		
CSA Standard	CE	UL Standard	CSA Standard	CE	UL Standard	CSA Standard	CE	UL Standard	CSA Standard	CE	UL Standard
15-7 AWG	1.5-10 sq.mm	16-6 AWG	14-6 AWG	2.5-16 sq.mm	14-6 AWG	9-3 AWG	6-25 sq.mm	14-2 AWG	7-2 AWG	10-35sq.mm	18-1/0 AWG
600 V	750 V	600 V	600 V	750 V	600 V	600 V	750 V	600 V	600 V	750 V	600 V
65 A	57 A	65 A	70 A	76 A	70 A	115 A	101 A	115 A	145 A	125 A	145 A
14 lb-in	1.2 Nm	14 lb-in	14 lb-in	2.0 Nm	14 lb-in	14 lb-in	2.0 Nm	14 lb-in	25 lb-in	2.5 Nm	25 lb-in
Type Cat No.	Std. Packing in Nos.	Wt Per unit in Grams	Type Cat No.	Std. Packing in Nos.	Wt Per unit in Grams	Type Cat No.	Std. Packing in Nos.	Wt Per unit in Grams	Type Cat No.	Std. Packing in Nos.	Wt Per unit in Grams
SCRW10UCR	100	17.5	SCRW16UCR	50	25	SCRW25UCR	50	35	SCRW35UCR	50	49
EPSCRW6U/10U	50	2.2				EPSCRW25U	50	2.4	EPSCRW35U	50	3.6
PPSCRW6U/10U	50	2.9	SPSCRW16U	100		PPSCRW25U	50	4.2	PPSCRW35U	50	4.9
DIN 32G	50 M	750	DIN 32G	50 M	760	DIN 32G	50 M	750	DIN 32G	50 M	750
DIN 35U	50 M	360	DIN 35U	50 M	360	DIN 35U	50 M	360	DIN 35U	50 M	360
DIN 35-15D	50 M	700	DIN 35-15D	50 M	700	DIN 35-15D	50 M	700	DIN 35-15D	50 M	700
ES1S	50	15.3	ES1S			ES1S	50	15.3	ES1S	50	15.3
ES2S	50	15.1	ES2S			ES2S	50	15.1	ES2S	50	15.1
ES3S	50	7.0	ES2N	50	7.4	ES3S	50	7.0	ES3S	50	7.0
ES2N	50	7.4	ES3N	50	4.5	ES2N	50	7.4	ES2N	50	7.4
ES3N	50	4.5	ES3S			ES3N	50	4.5	ES3N	50	4.5
PASL10/2	10	6.4	PASL12/2A	100	6.4	PASL12/2	10	11.6	PASL15/2	10	12.2
PASL10/3	10	9.6	PASL12/3A	50	9.6	PASL12/3	10	17.8	PASL15/3	10	18.8
PASL10/4	10	13	PASL12/4A	50	13	PASL12/4	10	24.1	PASL15/4	10	25.5
PASL10/10	10	32.4	PASL12/10A	10	32.4	PASL12/10	10	60.4	PASL15/10	10	63.4
PSL10/2	100	0.95	PSL12/2A	100		PSL12/2	100	1.5	PSL15/2	100	1.9
PSL10/3	100	1.5	PSL12/3A	100		PSL12/3	100	2.5	PSL15/3	100	3.5
PSL10/4	100	2.2	PSL12/4A	100		PSL12/4	100	3.7	PSL15/4	100	5
PSL10/10	100	5.4	PSL12/10A	10		PSL12/10	100	8.9	PSL15/10	100	11.9
SS03	100	2.64	SS05	50	2.64	SS04	50	5.15	SS04	50	5.15
RSL10	100	0.75	RSL12	100	0.75	RSL12A	100	1.2	RSL15	100	1.7
SL02	100	3.7	SL05	50	3.7	SL03	50	7.39	SL03	50	7.39
KM/10	100	0.16	KM/12 KM/9F	100 10	0.16	KM/12	100	0.2	KM/15	100	0.24

## Standard, Feed-Through Spring Clamp Terminals

In certain applications, with smaller cross section wires, "screw-less" spring clamp terminals are preferred.

In screw clamp terminals, it is the screw clamp that holds the wire against the current bar, whereas in spring clamp terminals, the wire is held against the current bar directly by a pre-stressed spring clamp.

The pre-stressed spring clamp is opened by using an appropriate screw driver to provide access to wire through the opening in the spring clamp. The conductor is pulled against the current bar and gets clamped by the spring force when the screw driver is removed. The recommended blade size of the screw driver is 3mm × 0.6mm, 3.5mm × 0.6mm and

4.5mm × 0.8mm for CAGE2.5, CAGE4 and CAGE6 terminals respectively.

Spring clamp terminals have top wire entry and are suitable for mounting on DIN 35 and DIN 35-15 rails.

Insulated push-in type shorting link wire, besides providing shock protection, simplifies the task of cross connection.

The terminals have marker holding recesses to accept international "K" type markers.



**CAGE2.5**

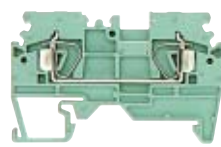

**CAGE4**

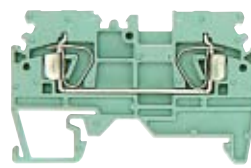

**CAGE6**

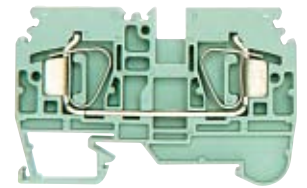

Terminal Pitch	5 mm			6 mm			8 mm			
Height x Width	36 x 58 mm			42 x 65 mm			45 x 72 mm			
Connection Possibility	Stranded Wire Solid Wire			0.5 - 4 sq. mm 0.5 - 4 sq. mm			0.5 - 4 sq. mm 0.5 - 6 sq. mm			
Stripping Length	9 mm			9 mm			12 mm			
Insulation Material	Polyamide 6.6			Polyamide 6.6			Polyamide 6.6			
Type of Connection	2 Spring clamp connection and 2 slots for interconnection			2 Spring clamp connection and 2 slots for interconnection			2 Spring clamp connection and 2 slots for interconnection			
Standards										
Rated Cross Section	22-14 AWG	2.5 sq. mm	22-14 AWG	22-12 AWG	4 sq. mm	22-12 AWG	22-8 AWG	6 sq. mm	22-8 AWG	
Voltage Rating	600 V	750 V	600 V	600 V	750 V	600 V	600 V	750 V	600 V	
Current Rating	20 A	24 A	20 A	25 A	32 A	25 A	50 A	41 A	50 A	
	<b>Type Cat No.</b>	<b>Std. Packing in Nos.</b>	<b>Wt Per unit in Grams</b>	<b>Type Cat No.</b>	<b>Std. Packing in Nos.</b>	<b>Wt Per unit in Grams</b>	<b>Type Cat No.</b>	<b>Std. Packing in Nos.</b>	<b>Wt Per unit in Grams</b>	
Terminal Station	CAGE2.5	100	5.7	CAGE4	100	10	CAGE6	50	15	
End Plate	EPCAGE2.5	50	2.5	EPCAGE4	50	4.5	EPCAGE6	50	6.5	
Partition Plate	PPCAGE2.5	50	3.5	PPCAGE4	50	5.5	PPCAGE6	50	7.5	
Mounting Rail	DIN 35U DIN 35-15D	50 M 50 M	360 700	DIN 35U DIN 35-15D	50 M 50 M	360 700	DIN 35U DIN 35-15D	50 M 50 M	360 700	
End Clamp	ES1S ES2S ES2N ES3N	50 50 50 50	15.3 15.1 7.4 4.5	ES1S ES2S ES2N ES3N	50 50 50 50	15.3 15.1 7.4 4.5	ES1S ES2S ES2N ES3N	50 50 50 50	15.3 15.1 7.4 4.5	
Insulated Push-In type Shorting Link (2 way)	Consecutive Alternate	SL-PUSHIN5 SL-PUSHIN5A	100 100	1.2 2.2	SL-PUSHIN6 SL-PUSHIN6A	100 100	3 5	SL-PUSHIN8 SL-PUSHIN8A	100 100	4 6
Insulated Push-In type Shorting Link Wire		SL-PUSHIN5B	100	3	SL-PUSHIN6B	100	5	-	-	-
Marking Tags (K Type)		KM/5	100	0.1	KM/6	100	0.1	KM/8	100	0.1



## Multiple Connection, Feed-Through Spring Clamp Terminals

The multiple connection spring clamp terminals offer reliable solution for multiple wire connections. The terminal eliminates conventional cross connections, looping wires and reliability problems encountered when connecting two wires in one clamp.

The terminals provide multiple connection points in the terminal itself and possibility of further multiplication of connections through bridging.

The multiple connection terminal blocks can even be bridged to standard feed through spring clamp terminal blocks of same wire size.

CAGE2.5 1-2 and CAGE4 1-2 feature one termination point on one side and two termination points on the other side, while CAGE2.5 2-2 and CAGE4 2-2 have two termination points on both sides. Bridging facility is at the centre of the terminals.

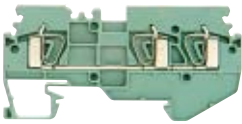
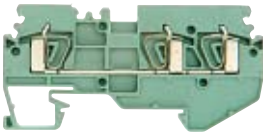
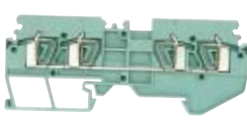
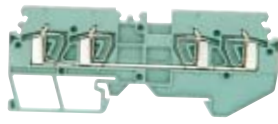
CAGE2.5 1-2			CAGE4 1-2			CAGE2.5 2-2			CAGE4 2-2		
											
5 mm			6 mm			5 mm			6 mm		
36 x 74 mm			42 x 84.6 mm			36 x 89.8 mm			42 x 105 mm		
0.5 - 2.5 sq. mm 0.5 - 4 sq. mm			0.5 - 4 sq. mm 0.5 - 6 sq. mm			0.5 - 2.5 sq. mm 0.5 - 4 sq. mm			0.5 - 4 sq. mm 0.5 - 6 sq. mm		
9 mm			9 mm			9 mm			9 mm		
Polyamide 6.6			Polyamide 6.6			Polyamide 6.6			Polyamide 6.6		
3 Spring clamp connections and 2 slots for interconnection			3 Spring clamp connections and 2 slots for interconnection			4 Spring clamp connections and 2 slots for interconnection			4 Spring clamp connections and 2 slots for interconnection		
CSA Standard	CE	UL US	CSA Standard	CE	UL US	CSA Standard	CE	UL US	CSA Standard	CE	UL US
22-14 AWG	2.5 sq. mm	22-14 AWG	22-12 AWG	4 sq. mm	22-12 AWG	22-14 AWG	2.5 sq. mm	22-14 AWG	22-12 AWG	4 sq. mm	22-12 AWG
600 V	750 V	600 V	600 V	750 V	600 V	600 V	750 V	600 V	600 V	750 V	600 V
20 A	24 A	20 A	25 A	32 A	25 A	20 A	24 A	20 A	25 A	32 A	25 A
Type Cat No.	Std. Packing in Nos.	Wt Per unit in Grams	Type Cat No.	Std. Packing in Nos.	Wt Per unit in Grams	Type Cat No.	Std. Packing in Nos.	Wt Per unit in Grams	Type Cat No.	Std. Packing in Nos.	Wt Per unit in Grams
CAGE2.5 1-2	100	9	CAGE4 1-2	100	15	CAGE2.5 2-2	100	12	CAGE4 2-2	100	20
EPCAGE2.5 1-2	50	2	EPCAGE4 1-2	50	3	EPCAGE2.5 2-2	50	4	EPCAGE4 2-2	50	6
PPCAGE2.5 1-2	50	3	PPCAGE4 1-2	50	4	PPCAGE2.5 2-2	50	5	PPCAGE4 2-2	50	7
DIN 35U DIN 35-15D	50 M 50 M	360 700	DIN 35U DIN 35-15D	50 M 50 M	360 700	DIN 35U DIN 35-15D	50 M 50 M	360 700	DIN 35U DIN 35-15D	50 M 50 M	360 700
ES1S	50	15.3	ES1S	50	15.3	ES1S	50	15.3	ES1S	50	15.3
ES2S	50	15.1	ES2S	50	15.1	ES2S	50	15.1	ES2S	50	15.1
ES2N	50	7.4	ES2N	50	7.4	ES2N	50	7.4	ES2N	50	7.4
ES3N	50	4.5	ES3N	50	4.5	ES3N	50	4.5	ES3N	50	4.5
SL-PUSHIN5	100	1.2	SL-PUSHIN6	100	3	SL-PUSHIN5	100	1.2	SL-PUSHIN6	100	3
SL-PUSHIN5A	100	2.2	SL-PUSHIN6A	100	5	SL-PUSHIN5A	100	2.2	SL-PUSHIN6A	100	5
SL-PUSHIN5B	100	3	SL-PUSHIN6B	100	5	SL-PUSHIN5B	100	3	SL-PUSHIN6B	100	5
KM/5	100	0.1	KM/6	100	0.1	KM/5	100	0.1	KM/6	100	0.1

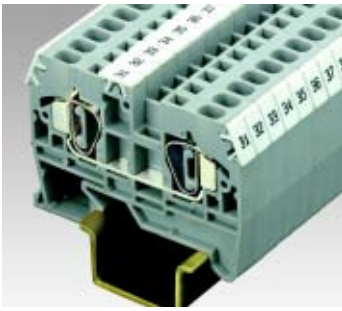

	CAGE6 1-2			CAGE6 2-2		
Terminal Pitch	8 mm			8 mm		
Height x Width	45 x 94 mm			45 x 116 mm		
Connection Possibility	Stranded Wire Solid Wire			0.5 - 6 sq. mm 0.5 - 10 sq. mm		
Stripping Length	12 mm			12 mm		
Insulation Material	Polyamide 6.6			Polyamide 6.6		
Type of Connection	3 Spring clamp connections and 2 slots for interconnection			4 Spring clamp connections and 2 slots for interconnection		
Standards	CSA Standard	CE	UL Standard	CSA Standard	CE	UL Standard
Rated Cross Section	22-8 AWG	0.5-6 sq. mm	22-8 AWG	22-8 AWG	0.5-6 sq. mm	22-8 AWG
Voltage Rating	600 V	750 V	600 V	600 V	750 V	600 V
Current Rating	50 A	41 A	50 A	50 A	41 A	50 A
	<b>Type Cat No.</b>	<b>Std. Packing in Nos.</b>	<b>Wt Per unit in Grams</b>	<b>Type Cat No.</b>	<b>Std. Packing in Nos.</b>	<b>Wt Per unit in Grams</b>
Terminal Station	CAGE6 1-2	50	5	CAGE6 2-2	100	20
End Plate 	EPCAGE6 1-2	50	6	EPCAGE6 2-2	50	6
Partition Plate 	PPCAGE6 1-2	50	4	PPCAGE6 2-2	50	7
Mounting Rail 	DIN 35U DIN 35-15D	50 M 50 M	360 700	DIN 35U DIN 35-15D	50 M 50 M	360 700
End Clamp 	ES1S ES2S ES2N ES3N	50 50 50 50	15.3 15.1 7.4 4.5	ES1S ES2S ES2N ES3N	50 50 50 50	15.3 15.1 7.4 4.5
Insulated Push-In type Shorting Link (2 way) 	SL-PUSHIN8 SL-PUSHIN8A	100 100	3 5	SL-PUSHIN8 SL-PUSHIN8A	100 100	3 5
Insulated Push-In type Shorting Link Wire  Current Rating : 10A, wire length 110mm.	SL-PUSHIN8B	100	5	SL-PUSHIN8B	100	5
Marking Tags (K Type) 	KM/8	100	0.1	KM/8	100	0.1

## Multiple Connection, Feed-Through Screw Clamp Terminals

The multiple connection terminals offer reliable solution for different voltage connections in wiring. Conventionally, either wire looping or cross connections are used. While looping is unsafe, cross connecting requires more terminals and additional space.

The multiple connection terminals provide :

- Multiple connection points in the terminal.
- Further multiplication of connections through bridging point/points in the terminal.

SCRW4U 1-2 Multiple Connection Terminals provide one terminal point on one side and two terminal points on the other side. Bridging facility is at the centre of the terminal.

SCRW4U 2-2 Multiple Connection Terminals provide two terminal points on each side of the terminal and also two points for cross connection at the centre. This simplifies the task of accommodating several wires safely and efficiently.

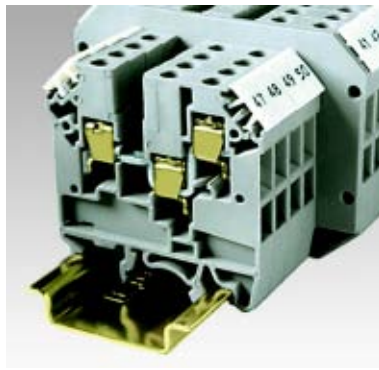

	SCRW4U 1-2			SCRW4U 2-2		
Terminal Pitch	6 mm			6 mm		
Height x Width	47 x 46.5 mm			51.5 x 65 mm		
Connection Possibility	Stranded Wire Solid Wire			0.5 to 4 sq.mm 0.5 to 6 sq.mm		
Stripping Length	9 mm			9 mm		
Insulation Material	Polyamide 6.6			Polyamide 6.6		
Type of Connection	3 screw clamps and 1 tapped hole for cross connection			4 screw clamps and 2 tapped holes for cross connection		
Approvals						
Rated Cross Section	22-12AWG	0.5-4 sq.mm	22-10 AWG	22-12AWG	0.5-4 sq.mm	22-10 AWG
Voltage Rating	600 V	600 V	600 V	600 V	600 V	600 V
Current Rating	25 A	32 A	**35 A	25 A	32 A	**35 A
Torque	7 lb-in	0.5 Nm	7 lb-in	7 lb-in	0.5 Nm	7 lb-in
	<b>Type Cat No.</b>	<b>Std. Packing in Nos.</b>	<b>Wt Per unit in Grams</b>	<b>Type Cat No.</b>	<b>Std. Packing in Nos.</b>	<b>Wt Per unit in Grams</b>
Terminal Station	SCRW4U 1.2	100	10.8	SCRW4U 2-2	50	15.8
End Plate	EPSCRW4U 1-2	50	2.4	EPSCRW4U 2-2	50	3.4
Mounting Rail		DIN 32G 50 M 750 DIN 35J 50 M 360 DIN 35-15D 50 M 700			DIN 32G 50 M 750 DIN 35J 50 M 360 DIN 35-15D 50 M 700	
End Clamp		ES1S 50 15.3 ES2S 50 15.1 ES2N 50 7.4 ES3N 50 4.5			ES1S 50 15.3 ES2S 50 15.1 ES2N 50 7.4 ES3N 50 4.5	
Pre Assembled Shorting Links	 2 way 3 way 4 way 10 way	PASL06/2 10 2.2 PASL06/3 10 3.2 PASL06/4 10 3.9 PASL06/10 10 11.5		 2 way 3 way 4 way 10 way	PASL06/2 10 2.2 PASL06/3 10 3.2 PASL06/4 10 3.9 PASL06/10 10 11.5	
Permanent Shorting Link	 2 way 3 way 4 way 10 way	PSL06/2 100 0.3 PSL06/3 100 0.5 PSL06/4 100 0.7 PSL06/10 100 1.7 *PASL/10A 100 1.53		 2 way 3 way 4 way 10 way	PSL06/2 100 0.3 PSL06/3 100 0.5 PSL06/4 100 0.7 PSL06/10 100 1.7 *PASL/10A 100 1.53	
Short Sleeve for quick Permanent Shorting	SS02	100	1.16	SS02	100	1.16
Removable Shorting Link	RSL6	100	0.25	RSL6	100	0.25
Long Sleeve for quick Temporary Shorting	SL04	100	1.73	SL04	100	1.73
**Comb Link	 2 way 3 way 4 way 10 way	CL6/2 100 1.2 CL6/3 100 1.8 CL6/4 100 2.4 CL6/10 50 6.0		 2 way 3 way 4 way 10 way	CL6/2 100 1.2 CL6/3 100 1.8 CL6/4 100 2.4 CL6/10 50 6.0	
Marking Tags (K Type)	KM/6	100	0.1	KM/6	100	0.1

\*\*Comb link can be used in the upper level of the clamping unit.

\*\* Limited VA rating of 5 A maximum at 600 V for General Industrial use.

\* 10 way breakable shorting link.

# Micro, Feed-Through Terminals

The micro terminals, besides offering the obvious space advantage essential for compact wiring systems, are functionally as versatile as standard screw clamp terminals. They are also available for solder connections in two types. The terminals are modular in construction and can be mounted on DIN 15 rails.

The terminals have marker holding recesses to accept international 'K' type marking tags.

Cross connections can be achieved with shorting links/sleeves.

Further, M4SU Terminals are offered, identical to M4S except the following:

- 2 solder points are at uneven level and interchanged in alternate terminals, thus facilitating wire termination due to offset levels of terminals when mounted side-by-side.
- CSA and UL (Limited VA rating of 10 A maximum at 300 V for General Industrial use) ratings are 15A instead of 25A for M4S.



M4SU Terminals carry the same international certification marks as M4S.

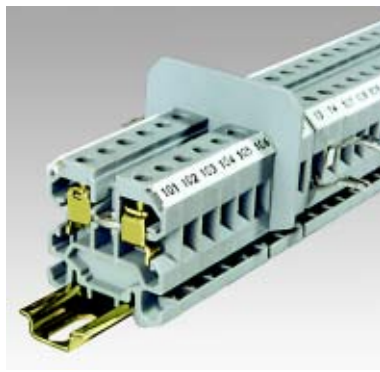

		M4			M4S		
Terminal Pitch		6 mm			6 mm		
Height x Width		29 x 27 mm			29 x 27 mm		
Connection Possibility	Stranded Wire Solid Wire	0.5 to 4 sq.mm 0.5 to 6 sq.mm			0.5 to 4 sq.mm 0.5 to 4 sq.mm		
Stripping Length		9 mm			9 mm		
Insulation Material		Polyamide 6.6			Polyamide 6.6		
Type of Connection		2 screw clamps and 1 tapped hole for cross connection			2 screw clamp, 2 solder points and 1 tapped hole for cross connection		
Approvals							
Rated Cross Section		22-12 AWG	0.5 - 4 sq.mm	22-10 AWG	22-12 AWG	Upto 1.5 sq.mm	22-10 AWG
Voltage Rating		300 / 600 V	400 V	300 V	300 / 600 V	160 V	300 V
Current Rating		25 A	32 A	35 A	25 A	15 A	35 A
Torque		6 lb-in	0.5 Nm	6 lb-in	7 lb-in	0.5 Nm	7 lb-in
		<b>Type Cat No.</b>	<b>Std. Packing in Nos.</b>	<b>Wt Per unit in Grams</b>	<b>Type Cat No.</b>	<b>Std. Packing in Nos.</b>	<b>Wt Per unit in Grams</b>
Terminal Station		M4	100	4.8	M4S	50	5.1
End Plate		EPM4	50	1	EPM4	50	1
Partition Plate		PPM4	50	2	PPM4	50	2
Mounting Rail		DIN 15	50 M	150	DIN 15	50 M	150
End Clamp		ES1N	50	2.5	ES1N	50	2.5
Pre Assembled Shorting Links	2 way 3 way 4 way 10 way 	PASL6/2A PASL6/3A PASL6/4A PASL6/10A	10 10 10 10	1.1 1.25 1.5 9.5	PASL6/2A PASL6/3A PASL6/4A PASL6/10A	10 10 10 10	1.1 1.25 1.5 9.5
Permanent Shorting Link	2 way 3 way 4 way 10 way 	PSL06/2 PSL06/3 PSL06/4 PSL06/10	100 100 100 100	0.3 0.5 0.7 1.7	PSL06/2 PSL06/3 PSL06/4 PSL06/10	100 100 100 100	0.3 0.5 0.7 1.7
Short Sleeve for quick Permanent Shorting		SS01	100	0.7	SS01	100	0.7
Removable Shorting Link		RSL6A	100	0.25	RSL6A	100	0.25
Long Sleeve for quick Temporary Shorting		SL01	100	1.28	SL01	100	1.28
Breakable Shorting Link (10 way)		PASL/10A	100	1.53	PASL/10A	100	1.53
Comb Link	2 way 3 way 4 way 10 way 	CL6/2B CL6/3B CL6/4B CL6/10B	100 100 100 50	1.2 1.8 2.4 6.0	CL6/2B CL6/3B CL6/4B CL6/10B	100 100 100 50	1.2 1.8 2.4 6.0
Marking Tags (K Type)		KM/2	100	0.02	KM/2	100	0.02

## Double Level, Feed-Through Terminals









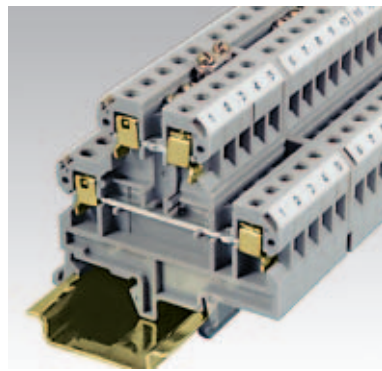







The double level terminals facilitate high wiring density unavoidable in certain wiring arrangements. Besides other advantages of "U" Series terminals, double level terminals have the following additional facilities.

- Double wiring density without extension of mounting rails.
- Interconnection/shorting can be done at both levels.
- Marking/identification by marking tags possible at both levels.

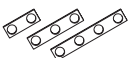
DBL4U(I.S) internally shorted double level terminals are useful for distribution application using shorting links at lower level.

DBL4U terminals with marker KM/2 for marking facility at the centre of the terminal and terminals with Separator Plate, Cat.No: SPDBL4U, having provision on both the levels for segregating sets of consecutively shorted terminals is available on request.



		DBL4U			DBL4U(I.S)			
Terminal Pitch		6 mm			6 mm			
Height x Width		54 x 55.5 mm			54 x 55.5 mm			
Connection Possibility		Stranded Wire Solid Wire			0.5 to 4 sq.mm 0.5 to 6 sq.mm			
Stripping Length		9 mm			9 mm			
Insulation Material		Polyamide 6.6			Polyamide 6.6			
Type of Connection		4 screw clamps and 2 tapped holes for cross connection			4 screw clamps and 1 tapped hole for cross connection			
Approvals		  			  			
Rated Cross Section		22-12 AWG	0.5 - 4 sq.mm	22-10 AWG	22-12 AWG	0.5 - 4 sq.mm	22-10 AWG	
Voltage Rating		300 / 600 V	400 V	300 V	600 V	400 V	600 V	
Current Rating		25 A	32 A	35 A	25 A	32 A	35 A	
Torque		6 lb-in	0.5 Nm	6 lb-in	7 lb-in	0.5 Nm	7 lb-in	
		<b>Type Cat No.</b>	<b>Std. Packing in Nos.</b>	<b>Wt Per unit in Grams</b>	<b>Type Cat No.</b>	<b>Std. Packing in Nos.</b>	<b>Wt Per unit in Grams</b>	
Terminal Station		DBL4U	100	13	DBL4U(I.S)	100	15	
End Plate 		EPDBL4U	50	2.5	EPDBL4U	50	2.5	
Mounting Rail 		DIN 32G DIN 35U DIN 35-15D	50 M 50 M 50 M	750 360 700	DIN 32G DIN 35U DIN 35-15D	50 M 50 M 50 M	750 360 700	
End Clamp 		ES1S ES2S ES3S ES2N ES3N	50 50 50 50 50	15.3 15.1 7.0 7.4 4.5	ES1S ES2S ES3S ES2N ES3N	50 50 50 50 50	15.3 15.1 7.0 7.4 4.5	
Pre Assembled Shorting Links 		2 way 3 way 4 way 10 way	PASL6/2A PASL6/3A PASL6/4A PASL6/10A	10 10 10 10	1.1 1.25 1.5 9.5	PASL6/2A PASL6/3A PASL6/4A PASL6/10A	10 10 10 10	1.1 1.25 1.5 9.5
Permanent Shorting Link 		2 way 3 way 4 way 10 way	PSL06/2 PSL06/3 PSL06/4 PSL06/10	100 100 100 100	0.3 0.5 0.7 1.7	PSL06/2 PSL06/3 PSL06/4 PSL06/10	100 100 100 100	0.3 0.5 0.7 1.7
Short Sleeve for quick Permanent Shorting 			SS01	100	0.7	SS01	100	0.7
Removable Shorting Link 			RSL6A	100	0.25	RSL6A	100	0.25
Long Sleeve for quick Temporary Shorting 			SL01	100	1.28			
Breakable Shorting Link (10 way) 			PASL/10A	100	1.53	PASL/10A	100	1.53
Comb Link 		2 way 3 way 4 way 10 way	CL6/2B CL6/3B CL6/4B CL6/10B	100 100 100 50	1.2 1.8 2.4 6.0	CL6/2B CL6/3B CL6/4B CL6/10B	100 100 100 50	1.2 1.8 2.4 6.0
Marking Tags (K Type) 			KM/2	100	0.02	KM/2	100	0.02

## Offset Double Level, Feed-Through Terminals

The offset double level terminals not only provide separate connection possibility at two levels, but the top level is offset from bottom level by half the thickness of terminal.

Therefore the DBLOFF terminals offer following advantages.

- Double wiring density without extension of mounting rails.
- Bottom level screws have better accessibility for tightening/loosening.
- Easier interconnections and shorting can be done at both levels.
- Marking tags of bottom level are not obstructed by wires connected at top level.

It is recommended to use spacer or end plate at both the ends of assembled set of DBLOFF terminals for flat alignment to enable effective use of end stops or clamps.

“Add-On” type DBLOFF terminal block is available on request.

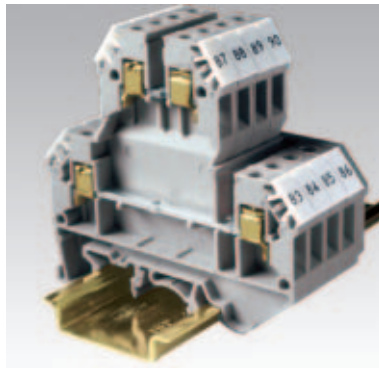

### DBLOFF4U

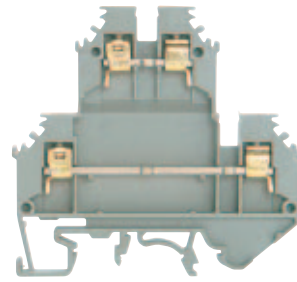

Terminal Pitch		6 mm		
Height x Width		63 x 68 mm		
Connection Possibility	Stranded Wire	0.5 to 4 sq.mm		
	Solid Wire	0.5 to 6 sq.mm		
Stripping Length		9 mm		
Insulation Material		Polyamide 6.6		
Type of Connection		4 screw clamps and 2 tapped holes for cross connection		
Approvals				
Rated Cross Section		22-12 AWG	0.5-4 sq.mm	22-10 AWG
Voltage Rating		600 V	600 V	600 V
Current Rating		25 A	32 A	##35 A
Torque		7 lb-in	0.5 Nm	7 lb-in
		<b>Type Cat No.</b>	<b>Std. Packing in Nos.</b>	<b>Wt Per unit in Grams</b>
Terminal Station		DBLOFF4U	50	13
End Plate	Front Side	EPDBLOFF4U	50	4.2
	Back Side	EPDBLOFF4UA	50	2.5
Mounting Rail		DIN 32G	50 M	750
		DIN 35U	50 M	360
		DIN 35-15D	50 M	700
End Clamp		ES1S	50	15.3
		ES2S	50	15.1
		ES3S	50	7.0
		ES2N	50	7.4
		ES3N	50	4.5
Pre Assembled Shorting Links	2 way	PASL6/2A	10	1.1
	3 way	PASL6/3A	10	1.25
	4 way	PASL6/4A	10	1.5
	10 way	PASL6/10A	10	9.5
Permanent Shorting Link	2 way	PSL06/2	100	0.3
	3 way	PSL06/3	100	0.5
	4 way	PSL06/4	100	0.7
	10 way	PSL06/10	100	1.7
Short Sleeve for quick Permanent Shorting		SS01	100	0.7
Removable Shorting Link		RSL6A	100	0.25
Long Sleeve for quick Temporary Shorting		SS01	100	1.28
Breakable Shorting Link (10 way)		PASL/10A	100	1.53
Comb Link	2 way	CL6/2B	100	1.2
	3 way	CL6/3B	100	1.8
	4 way	CL6/4B	100	2.4
	10 way	CL6/10B	50	6.0
Marking Tags (K Type)		KM/6	100	0.1

## Limited VA rating of 5 A maximum at 600 V for General Industrial use.

## Triple Level, Feed-Through Terminals

The triple level terminals are ideal for control systems with sensors and actuators. The simplified three level connections allow higher wiring density in the circuits. The TL2.5U terminals, with feed through connecting points at all the 3 levels, offer multiple choice of signal and power distribution at any level. Use of cross connecting links and internal jumpers is recommended to reduce looping of wires.

In TL2.5UH, the top level provides connecting points for signal while

middle and bottom level connecting points are used for positive and negative potentials.

In applications where switching indication is required, option of triple level terminal blocks with built-in "LED Indication" are offered as TL2.5UL and TL2.5UHL.

Blue and red, besides conventional white marking tags are used for effective identification. The terminals are for universal rail mounting.

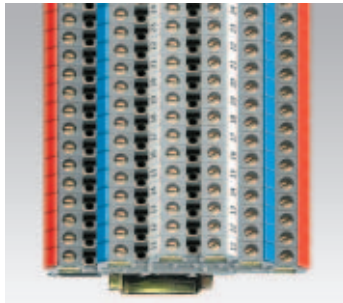

	TL2.5U#			TL2.5UH			TL2.5UHL			
Terminal Pitch	6 mm			6 mm			6 mm			
Height x Width	67 x 84 mm			67 x 61 mm			67 x 61 mm			
Connection Possibility	Flexible/Stranded Rigid/Solid			0.5 - 2.5 sq. mm 0.5 - 4 sq. mm			0.5 - 2.5 sq. mm 0.5 - 4 sq. mm			
Stripping Length	9 mm			9 mm			9 mm			
Insulation Material	Polyamide 6.6			Polyamide 6.6			Polyamide 6.6			
Type of Connection	6 screw clamps and 3 tapped holes for cross connection			4 screw clamps and 3 tapped holes for cross connection			*4 screw clamps and 3 tapped holes for cross connection			
Standards	CSA	CE	UL US	CSA	CE	UL US	CSA	CE	UL US	
Rated Cross Section	24-12 AWG	0.5-2.5 sq.mm	22-12 AWG	24-12 AWG	0.5-2.5 sq.mm	22-12 AWG	24-14 AWG	0.5-4 sq.mm	22-12 AWG	
Voltage Rating	300 V	500 V	300 V	300 V	500 V	300 V	300 V	500 V	300 V	
Current Rating	25 A	24 A	25 A	25 A	24 A	25 A	25 A	24 A	20 A	
Torque	4.5 lb-in	0.4 Nm	4.5 lb-in	4.5 lb-in	0.4 Nm	4.5 lb-in	7 lb-in	0.4 Nm	7 lb-in	
Terminal Station	Type Cat No.	Std. Packing in Nos.	Wt Per unit in Grams	Type Cat No.	Std. Packing in Nos.	Wt Per unit in Grams	Type Cat No.	Std. Packing in Nos.	Wt Per unit in Grams	
End Plate	TL2.5U	50	16	TL2.5UH	50	14	TL2.5UHL	50	16	
Mounting Rail	DIN 32G	50 M	750	DIN 32G	50 M	750	DIN 32G	50 M	750	
	DIN 35U	50 M	360	DIN 35U	50 M	360	DIN 35U	50 M	360	
	DIN 35-15D	50 M	700	DIN 35-15D	50 M	700	DIN 35-15D	50 M	700	
End Clamp	ES1S	50	15.3	ES1S	50	15.3	ES1S	50	15.3	
	ES2S	50	15.1	ES2S	50	15.1	ES2S	50	15.1	
	ES3S	50	7.0	ES3S	50	7.0	ES3S	50	7.0	
	ES2N	50	7.4	ES2N	50	7.4	ES2N	50	7.4	
	ES3N	50	4.5	ES3N	50	4.5	ES3N	50	4.5	
Pre Assembled Shorting Link	2 way	PASL06/2	10	2.2	PASL06/2	10	2.2	PASL06/2	10	2.2
	3 way	PASL06/3	10	3.2	PASL06/3	10	3.2	PASL06/3	10	3.2
	4 way	PASL06/4	10	3.9	PASL06/4	10	3.9	PASL06/4	10	3.9
	10 way	PASL06/10	10	11.5	PASL06/10	10	11.5	PASL06/10	10	11.5
Insulated Comb Links	2 way	CL6/2C	100	1.2	CL6/2C	100	1.2	CL6/2C	100	1.2
	3 way	CL6/3C	100	1.8	CL6/3C	100	1.8	CL6/3C	100	1.8
	4 way	CL6/4C	100	2.4	CL6/4C	100	2.4	CL6/4C	100	2.4
	10 way	CL6/10C	50	6.0	CL6/10C	50	6.0	CL6/10C	50	6.0
Marking Tags (K Type)	KM/2	100	0.1	KM/2	100	0.1	KM/2	100	0.1	

# Choice of on-line indication in TL2.5U Terminal is offered as TL2.5UL.

Voltage rating will depend upon desired LED circuit.

Voltage rating will depend upon desired LED circuit.

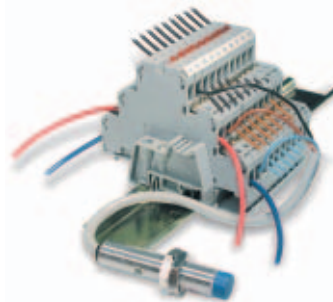

## Panel Mount, Feed-Through Screw Clamp Terminals

The modular panel mounting terminals ensure extremely compact wiring. The terminals are "add-on" to be stacked to form multipole assembly. The stacked assembly is fitted with end plates on both ends for easy installation on to the panel. With more than 20 terminals stacked, additional end plates must be mounted after every twentieth terminal terminal block for rigidity of assembly. The terminals have recesses to accept 'K' type marking tags. Cross connections can be achieved with shorting links/sleeves.

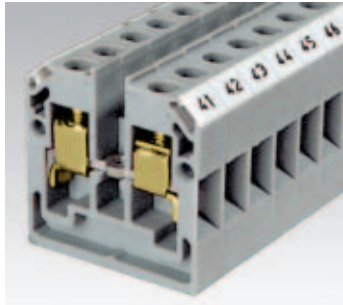

**P4**

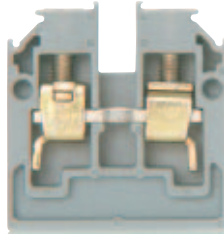

## Panel Mount, Feed-Through Spring Clamp Terminals

"Screwless" spring clamp panel mounting terminals offer cost effective compact wiring solution with all the advantages of spring clamp termination. Their application is similar to panel mount, screw clamp terminals.

CAGEP2.5 2-2 terminals provide two terminal points on each connection side with:

- multiple connection points in the terminal
- further multiplication of connections through bridging.

**CAGEP2.5**

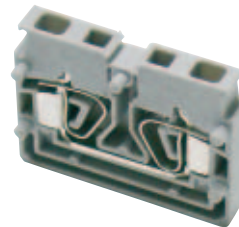

**CAGEP2.5 2-2**



Terminal Pitch	6 mm			5 mm			10 mm		
Height x Width	28 x 27 mm			27 x 35 mm			27 x 35 mm		
Connection Possibility	Stranded Wire Solid Wire			0.5 to 4 sq.mm 0.5 to 6 sq.mm			0.5 - 2.5 sq. mm 0.5 - 4 sq. mm		
Stripping Length	9 mm			9 mm			9 mm		
Insulation Material	Polyamide 6.6			Polyamide 6.6			Polyamide 6.6		
Type of Connection	2 screw clamps and 1 tapped hole for cross connection			2 spring clamps			4 spring clamps		
Approvals									
Rated Cross Section	22-12 AWG 0.5-4 sq.mm 22-10 AWG			22-14 AWG 2.5 sq. mm 22-14 AWG			22-14 AWG 2.5 sq. mm 22-14 AWG		
Voltage Rating	300 V 400 V 300 V			600 V 750 V 600 V			600 V 750 V 600 V		
Current Rating	25 A 32 A 35 A			20 A 24 A 20 A			20 A 24 A 20 A		
Torque	7 lb-in 0.5 Nm 7 lb-in								
Terminal Station	Type Cat No. P4 Std. Packing in Nos. 100 Wt Per unit in Grams 4			Type Cat No. CAGEP2.5 Std. Packing in Nos. 50 Wt Per unit in Grams 5.2			Type Cat No. CAGEP2.5 2-2 Std. Packing in Nos. 50 Wt Per unit in Grams 10		
End Plate / Stop	EPP4 50 2.2			EPCAGEP2.5 50 3			EPCAGEP2.5 50 3		
Fixing Screw (M 3)**									
Pre Assembled Shorting Links	 2 way PASL6/2A 10 1.1 3 way PASL6/3A 10 1.25 4 way PASL6/4A 10 1.5 10 way PASL6/10A 10 9.5								
Permanent Shorting Link	 2 way PSL06/2 100 0.3 3 way PSL06/3 100 0.5 4 way PSL06/4 100 0.7 10 way PSL06/10 100 1.7								
Short Sleeve for quick Permanent Shorting	SS01 100 0.7								
Removable Shorting Link	RSL6A 100 0.25								
Long Sleeve for quick Temporary Shorting	SL01 100 1.28								
Breakable Shorting Link (10 way)	PASL/10A 100 1.53			SL-PUSHIN5C 100 6.4			SL-PUSHIN5C 100 1.2		
Comb Link	 2 way CL6/2B 100 1.2 3 way CL6/3B 100 1.8 4 way CL6/4B 100 2.4 10 way CL6/10B 50 6.0								
Marking Tags (K Type)	KM/2 100 0.02			KM/2 100 0.1			KM/2 100 0.1		

\*\*M3 screw of appropriate length can be used.

\* Insulated Push-In type Shorting Link (2 way)



## Grounding (Earth), Terminals

Use of grounding terminals instead of grounding studs and wire lugs to terminate ground wires, saves installation and wiring time substantially.

Grounding terminals clamp mechanically onto the DIN Rail by tightening the center mounting screw, making a reliable electrical connection between the current bar and the DIN Rail. The rail serves as a busbar and automatically distributes ground potential to all other ground terminals on the same rail.

Grounding terminals can also be used as end stops, preventing other terminal blocks and components from moving laterally on the DIN Rail.

They are supplied with a standard green/yellow housing as per set norms for easy identification and accept international 'K' type marking tags.

Grounding terminals are for DIN 35 and DIN 32 rails.





Special features of grounding terminals are:

- Unbreakable housing in Polyamide 6.6 in green and yellow colour for easy identification.
- Tin-plated, brass foot for low contact grounding resistance.
- Vibration proof grounding by operating central screw.
- High torque clamping yokes for wide range of wires.

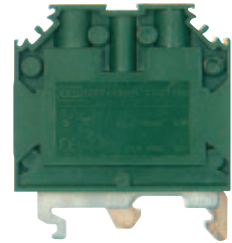
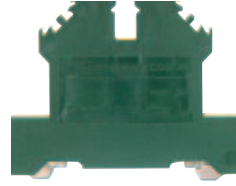
**G4**

**G10**



Terminal Pitch	6 mm			10 mm			
Height x Width	45.4 x 54.2 mm			50 x 45 mm			
Connection Possibility	Stranded Wire 0.5 to 4 sq.mm Solid Wire 0.5 to 6 sq.mm			1.5 to 10 sq.mm 1.5 to 16 sq.mm			
Stripping Length	9 mm			12 mm			
Insulation Material	Polyamide 6.6			Polyamide 6.6			
Type of Connection	2 screw clamps and grounding through central screw			2 screw clamp and grounding through central screw			
Approvals	  			   			
Rated Cross Section	22-12 AWG 0.5-4 sq. mm 22-12 AWG			16-8 AWG 1.5-10 sq.mm 16-8 AWG			
Current Rating	25 A 32 A 25 A			65 A 57 A			
Torque	7 lb-in 0.5 Nm 7 lb-in			14 lb-in 1.2 Nm 14 lb-in			
	<b>Type</b>	<b>Std. Packing</b>	<b>Wt Per u nit</b>	<b>Type</b>	<b>Std. Packing</b>	<b>Wt Per unit</b>	
	<b>Cat No.</b>	<b>in Nos.</b>	<b>in Grams</b>	<b>Cat No.</b>	<b>in Nos.</b>	<b>in Grams</b>	
Terminal Station	G4	50	21.5	G10	50	30	
Mounting Rail	DIN 32G	50 M	750	DIN 32G	50 M	750	
	DIN 35U	50 M	360	DIN 35U	50 M	360	
	DIN 35-15D	50 M	700	DIN 35-15D	50 M	700	
Marking Tags (K Type)		KM/6	100	0.1	KM/10	100	0.16

**G35**

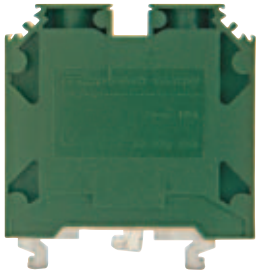

**GM4**



16 mm

6 mm

61.5 x 58 mm

28.5 x 27 mm

10 to 35 sq.mm  
10 to 50 sq.mm

0.5 to 4 sq.mm  
0.5 to 6 sq.mm

18 mm

9 mm

Polyamide 6.6

Polyamide 6.6

2 screw clamp and grounding through central screw

2 screw clamps and grounding through central screw



8-3 AWG 10-35 sq.mm 8-2 AWG

22-12AWG 0.5-4 AWG 22-12 AWG

145 A 125 A

25 A 32 A

25 lb-in 2.5 Nm 25 lb-in

7 lb-in 0.5 Nm 7 lb-in

Type Cat No.	Std. Packing in Nos.	Wt Per unit in Grams
--------------	----------------------	----------------------

Type Cat No.	Std. Packing in Nos.	Wt Per unit in Grams
--------------	----------------------	----------------------

G35	20	80
-----	----	----

GM4	100	
-----	-----	--

DIN 32G	50 M	750
DIN 35-15D	50 M	700

DIN 15	50 M	140
--------	------	-----

KM/15	100	0.24
-------	-----	------

KM/02	100	
-------	-----	--

# Spring Clamp Ground Terminals

'Screwless' Spring Clamp Ground terminal blocks are offered for quick connections and go well with other spring clamp terminal blocks. The spring clamp is operated by using a screw driver to provide an access to wire through the opening in the spring clamp. The wire is held against current bar directly by pre-stressed spring clamp. Specially designed alloy feet help in achieving very low contact resistance and vibration proof grounding.

CAGE series terminals can be mounted on DIN 35 rails along with other terminals and eliminate separate bus bar. The terminal

profile matches with the feed through terminal block of same wire size.

Special features of CAGE terminals are :

- Vibration proof grounding can be easily achieved by specially designed alloy feet
- Versatile special alloy feet to ensures very low contact resistance.
- Spring clamp to accept any type of wires.

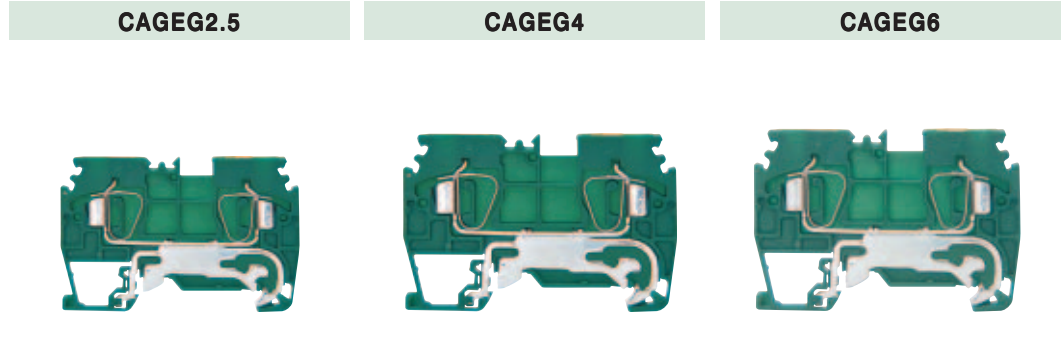

Terminal Pitch	5 mm			6 mm			8 mm		
Height x Width	36 x 58 mm			42 x 65 mm			45 x 72 mm		
Connection Possibility	Flexible Stranded Rigid Solid			0.5 to 2.5 sq.mm 0.5 to 4 sq.mm			0.5 to 4 sq.mm 0.5 to 6 sq.mm		
Stripping Length	9 mm			9 mm			12 mm		
Insulation Material	Polyamide 6.6			Polyamide 6.6			Polyamide 6.6		
Type of Connection	2 Spring clamp connection, grounding through alloy feet			2 Spring clamp connection, grounding through alloy feet			2 Spring clamp connection, grounding through alloy feet		
Approvals	CSA Standard	CE	UL Standard	CSA Standard	CE	UL Standard	CSA Standard	CE	UL Standard
Rated Cross Section	22-14 AWG	2.5 sq.mm	22-14 AWG	22-12 AWG	4 sq.mm	22-12 AWG	22-8 AWG	6 sq.mm	22-8 AWG
Current Rating	20 A	24 A		25 A	32 A		50 A	41 A	
	<b>Type Cat No.</b>	<b>Std. Packing in Nos.</b>	<b>Wt Per unit in Grams</b>	<b>Type Cat No.</b>	<b>Std. Packing in Nos.</b>	<b>Wt Per unit in Grams</b>	<b>Type Cat No.</b>	<b>Std. Packing in Nos.</b>	<b>Wt Per unit in Grams</b>
Terminal Station	CAGEG2.5	100		CAGEG4	100		CAGEG6	50	
Mounting Rail	DIN 35U DIN 35-15D	50 M 50 M	360 700	DIN 35U DIN 35-15D	50 M 50 M	360 700	DIN 35U DIN 35-15D	50 M 50 M	360 700
Marking Tags	KM/5	100	0.16	KM/6	100	0.16	KM/8	100	0.16s

## Panel Mount, Neutral/Earth Screw Clamp Busbar Systems

Certain electrical systems require termination of neutral/earth conductors to a convenient busbar. The GN4, GN16, GN35 terminals with busbars (NB) and busbar supports (NBS) offer a neat solution for such applications.

NB10 - 3 mm and NB6 - 6 mm, tin plated copper busbars are available in one metre lengths. Current carrying capacity of the busbar should be taken into account while connecting loads.





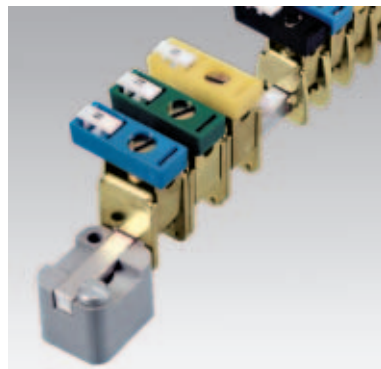

NBS plastic supports with fixing screws for holding 10 x 3 mm and 6 x 6 mm busbar ensures easy mounting. Busbars up to 200 mm length should be supported at ends by two busbar supports. For busbars exceeding 200 mm length, it is recommended to provide intermediate busbar support.

Easy to operate GN terminals secure wire to the busbar. The GN terminals have green cap as standard as most applications are for earthing. Optionally, caps with other colours such as blue, green and black can be offered on request. The GN terminals are with marking tag recesses for 'K' type marking tags for identification.



### GN4/16/35



Terminal Pitch		7.5 mm	9.8 mm	14.5 mm
Height x Width (mm)		30 x 23.3	36 x 23.3	45 x 27.3
Connection Possibility (sq.mm)	Stranded Wire Solid Wire	0.5 to 6 0.5 to 10	6 to 16 6 to 25	10 to 35 10 to 50
Stripping Length		12 mm	16 mm	16 mm
Insulation Material		Polyamide 6.6		
Type of Connection		1 screw clamp connection		
Approvals				
Rated Cross Section	GN4 GN16 GN35	22-12 AWG 9-6 AWG 7-2 AWG	0.5-6 sq.mm 6-16 sq.mm 10-35 sq.mm	22-12 AWG 10-6 AWG 8-2 AWG
Current Rating	GN4 GN16 GN35	25 A 76 A 125 A	41 A 76 A 125 A	NA NA NA
Torque	GN4 GN16 GN35	14 lb-in 14 lb-in 25 lb-in	0.8 Nm 2.0 Nm 2.5 Nm	14 lb-in 17.5 lb-in 25 lb-in
		<b>Type Cat No.</b>	<b>Std. Packing in Nos.</b>	<b>Wt Per unit in Grams</b>
Terminal Station		GN4 GN16 GN35	50 50 50	7.4 10.1 19
Busbar (10 x 3 mm)		NB10-3	1 M	52
Busbar (6 x 6 mm)		NB6-6	1 M	62
Plastic Support with Fixing Screw		NBS	50	7.1
Marking Tag (K Type)		KM/5	100	0.07

Note : Voltage Rating : 750 V

## Distribution Blocks

The 'U' Series DISBL compact distribution blocks are ideal for simplified distribution system. Polyamide 6.6 assembly is suitable for universal mounting. Lug/bolt connection at the centre for incoming cable and screw clamp connections for the outgoing monobloc conductors provide easy to connect points and ensure perfect continuity for distribution. A protective shield at centre effectively shrouds incoming connection.

### Important:

- Sum of outgoing currents on either side of centre should not exceed half the maximum permissible incoming current.
- Sum of total outgoing currents should not exceed maximum permissible incoming current.
- Connection for higher outgoing currents should be done through the terminal nearer to incoming connection at centre.

*DISBL4(1) compact distribution blocks are recommended for application where input connection point is located at one end instead of centre.*

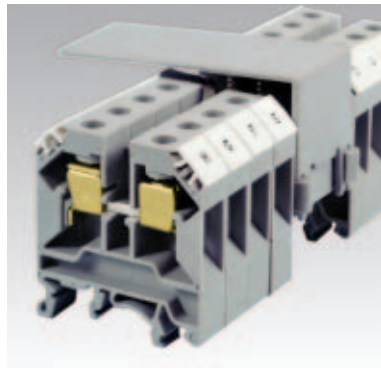

		DISBL4			DISBL4(1)		
Terminal Pitch		6 mm			6 mm		
Stripping Length		9 mm			9 mm		
Connection Possibility (Stranded Wire/Solid Wire)	Input Output	1.5 to 16 sq.mm 0.5 to 4 sq.mm / 0.5 to 6 sq.mm			1.5 to 16 sq.mm 0.5 to 4 sq.mm / 0.5 to 6 sq.mm		
Insulation Material		Polyamide 6.6			Polyamide 6.6		
Type of Connection	Input *Output	1 screw flat connection for ring lugs (Nut Driver operated) screw clamp connection (Screw Driver Operated)			1 screw flat connection for ring lugs (Nut Driver operated) screw clamp connection (Screw Driver Operated)		
Approvals							
Rated Cross Section	Input Output	10-8 AWG 22-12 AWG	6-16 sq.mm 0.5-4 sq.mm	10-8 AWG 22-12 AWG	10-8 AWG 22-12 AWG	6-16 sq.mm 0.5-4 sq.mm	10-8 AWG 22-12 AWG
Voltage Rating		600 V	750 V	600 V	600 V	750 V	600 V
Current Rating	Input Output (on either sides)	50 A 25 A	32 A	50 A 35 A	50 A 25 A	32 A	50 A 35 A
Torque	Input Output	26 lb-in 7 lb-in	2.0 Nm 0.5 Nm	26 lb-in 7 lb-in	26 lb-in 7 lb-in	2.0 Nm 0.5 Nm	26 lb-in 7 lb-in
		<b>Type Cat No.</b>	<b>Std. Packing in Nos.</b>	<b>Wt Per unit in Grams</b>	<b>Type Cat No.</b>	<b>Std. Packing in Nos.</b>	<b>Wt Per unit in Grams</b>
Terminal Station		DISBL4/1	10	46	DISBL4/2(1)	10	53
		DISBL4/2	10	60	DISBL4/3(1)	10	60
		DISBL4/3	10	74	DISBL4/4(1)	10	68
		DISBL4/4	10	90	DISBL4/5(1)	10	75
		DISBL4/5	10	104	DISBL4/6(1)	10	83
					DISBL4/10(1)	5	113
					DISBL4/11(1)	5	118
Mounting Rail		DIN 32G DIN 35U DIN 35-15D	50 M 50 M 50 M	750 360 700	DIN 32G DIN 35U DIN 35-15D	50 M 50 M 50 M	750 360 700
End Clamp		ES1S ES2S ES3S ES2N ES3N	50 50 50 50 50	15.3 15.1 7.0 7.4 4.5	ES1S ES2S ES3S ES2N ES3N	50 50 50 50 50	15.3 15.1 7.0 7.4 4.5
Marking Tags (K Type)		KM/6	100	0.1	KM/6	100	0.1
		<b>Type</b>	<b>H x W x T</b>	<b>No. of Output</b>	<b>Type</b>	<b>H x W x T</b>	<b>No. of Output</b>
		*DISBL4/1	45 x 43 x 43.8 mm	4	*DISBL4/2(1)	45 x 43 x 52 mm	4
		*DISBL4/2	45 x 43 x 55.8 mm	8	*DISBL4/3(1)	45 x 43 x 58 mm	6
		*DISBL4/3	45 x 43 x 67.8 mm	12	*DISBL4/4(1)	45 x 43 x 64 mm	8
		*DISBL4/4	45 x 43 x 80 mm	16	*DISBL4/5(1)	45 x 43 x 70 mm	10
		*DISBL4/5	45 x 43 x 96 mm	20	*DISBL4/6(1)	45 x 43 x 76 mm	12
					*DISBL4/10(1)	45 x 43 x 100 mm	20
					*DISBL4/11(1)	45 x 43 x 106 mm	22

\* Possible output configurations are mentioned below the Distribution Block details.

## DISBL6



8 mm

12 mm

6 to 25 sq.mm  
1.5 to 6 sq.mm / 1.5 to 10 sq.mm

Polyamide 6.6

1 screw flat connection for ring lugs  
(Nut Driver operated)  
screw clamp connection  
(Screw Driver Operated)



10-6 AWG 22-8 AWG	6-25 sq.mm 1.5-6 sq.mm	10-2 AWG 22-8 AWG
----------------------	---------------------------	----------------------

600 V	750 V	600 V
-------	-------	-------

95 A 50 A	41 A	100 A 50 A
--------------	------	---------------

25 lb-in 9 lb-in	3 Nm 0.8 Nm	35 lb-in 14 lb-in
---------------------	----------------	----------------------

Type Cat No.	Std. Packing in Nos.	Wt Per unit in Grams
DISBL6/2	10	91
DISBL6/3	10	117
DISBL6/4	10	145

## DISBL10

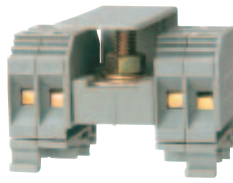

10 mm

12 mm

10 to 35 sq.mm  
1.5 to 10 sq.mm / 1.5 to 16 sq.mm

Polyamide 6.6

1 screw flat connection for ring lugs  
(Nut Driver operated)  
screw clamp connection  
(Screw Driver Operated)



7-2 AWG 15-7 AWG	10-35 sq.mm 1.5-10 sq.mm	8-1/0 AWG 16-6 AWG
---------------------	-----------------------------	-----------------------

600 V	750 V	600 V
-------	-------	-------

125 A 65 A	57 A	130 A 65 A
---------------	------	---------------

53 lb-in 14 lb-in	6 Nm 1.2 Nm	53 lb-in 14 lb-in
----------------------	----------------	----------------------

Type Cat No.	Std. Packing in Nos.	Wt Per unit in Grams
DISBL10/2	10	121
DISBL10/3	10	160
DISBL10/4	5	196

DIN 32G	50 M	750
DIN 35U	50 M	360
DIN 35-15D	50 M	700

ES1S	50	15.3
ES2S	50	15.1
ES3S	50	7.0
ES2N	50	7.4
ES3N	50	4.5

KM/8	100	0.11
------	-----	------

DIN 32G	50 M	750
DIN 35U	50 M	360
DIN 35-15D	50 M	700

ES1S	50	15.3
ES2S	50	15.1
ES3S	50	7.0
ES2N	50	7.4
ES3N	50	4.5

KM/10	100	0.16
-------	-----	------

Type	H x W x T	No. of Output
*DISBL6/2	43 x 48 x 64 mm	8
*DISBL6/3	43 x 48 x 80 mm	12
*DISBL6/4	43 x 48 x 96 mm	16

Type	H x W x T	No. of Output
*DISBL10/2	43 x 48 x 72 mm	8
*DISBL10/3	43 x 48 x 92 mm	12
*DISBL10/4	43 x 48 x 112 mm	16

## Safety Fuse Link Terminals

Certain electrical and control systems require fuse protection and the safety fuse terminal, with built-in fuse link offers a neat solution.

The safety fuse terminal has a hinged carrier, moving out as shown and having space for cartridge type glass fuse. The F terminals can take fuse of size Ø5 x 20 or Ø5 x 25 mm, while FA terminals can take fuse of size ¼" x 1¼" (6.35 x 31.75mm) required in the North America. The fuse can be engaged or disengaged by the movement of the carrier.

Spare fuse can be placed in the carrier of F4U, FDBL4U and FA4U terminals. Marking and identification by marking tags is possible on both terminal and the fuse carrier.

The safety fuse link terminals, F are also available with LED indication as F4U(L). A specially designed built-in circuit gives indication when fuse blows out, clearly identifying fault in the circuit. The FA4U terminals are also offered with LED or NEON indication as FA4UL and FA4UN respectively.

Application of such terminals must take into consideration residual current flow.

FDBL4U - double level fuse terminals with fuse link on the top level has a separate feed through terminal at lower level. This eliminates use of additional feed through terminals.

In FDBL4UE, a specially designed built-in circuit gives LED indication when a fuse blows out at the top level.

FDBL4U(LR) - This is a modified version of FDBL4UE terminal where in two equipotential connection points are available on both ends of the terminal.

Cross connection at lower level can be achieved with shorting links/sleeves.

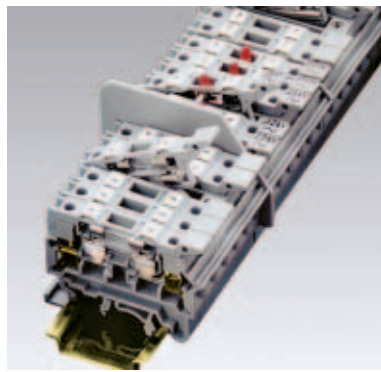

		F4U for Ø5 × 20/25 mm fuse			F4U(L) for Ø5 × 20/25 mm fuse with indicator		
Terminal Pitch		8 mm			8 mm		
Height x Width		43 x 58 mm			43 x 58 mm		
Connection Possibility	Stranded Wire Solid Wire	0.5 to 4 sq.mm 0.5 to 4 sq.mm			0.5 to 4 sq.mm 0.5 to 4 sq.mm		
Stripping Length		9.5 mm			9.5 mm		
Insulation Material		Polyamide 6.6			Polyamide 6.6		
Type of Connection		2 screw clamps equipped with safety connection			2 screw clamps equipped with safety connection		
Fusion Indication					24V AC, 24V DC, 48V AC, 48V DC, 110V AC, 110V DC, 220V AC		
Approvals			IEC Standard			IEC Standard	
Rated Cross Section		22-12 AWG	0.5-4 sq.mm	22-10 AWG	22-12 AWG	0.5-4 sq.mm	22-10 AWG
Voltage Rating		600 V	750 V	600 V	600 V	750 V	600 V
Current Rating	Top Level Bottom Level	6.3 A 25 A	6.3 A 32 A	6.3 A 35 A	6.3 A 25 A	6.3 A 32 A	6.3 A 35 A
Torque		7 lb-in	0.5 Nm	7 lb-in	7 lb-in	0.5 Nm	7 lb-in
		<b>Type Cat No.</b>	<b>Std. Packing in Nos.</b>	<b>Wt Per unit in Grams</b>	<b>Type Cat No.</b>	<b>Std. Packing in Nos.</b>	<b>Wt Per unit in Grams</b>
Terminal Station		F4U	100	13.5	F4U(L)	50	14
End Plate		EPF4U	50	2.2	EPF4U	50	2.2
Partition Plate		PPF4U	50	4.1	PPF4U	50	4.1
Mounting Rail		DIN 32G DIN 35U DIN 35-15D	50 M 50 M 50 M	750 360 700	DIN 32G DIN 35U DIN 35-15D	50 M 50 M 50 M	750 360 700
End Clamp**		ES3S ES2N	100 50	7.0 7.4	ES3S ES2N	100 50	7.0 7.4
* Pre Assembled Shorting Link	2 way 3 way 4 way 10 way 						
Permanent Shorting Link	2 way 3 way 4 way 10 way 						
Short Sleeve for quick permanent shorting							
Removable Shorting Link							
Long Sleeve for quick Temporary Shorting							
Comb Link	2 way 3 way 4 way 10 way 	CL8/2A CL8/3A CL8/4A CL8/10A	100 100 100 50	1.4 2.1 2.7 6.7	CL8/2A CL8/3A CL8/4A CL8/10A	100 100 100 50	1.4 2.1 2.7 6.7
Marking Tags (K Type on terminal) (K Type on fuse carrier)		KM/8 KM/2	100 100	0.11 0.02	KM/8 KM/2	100 100	0.11 0.02

\* Shorting possibility is in lower level only.

\*\*Other End Clamps, ES1S, ES2S and ES3N can also be used.

**Important:** In all safety fuse link terminals the disconnecting device (moving carrier) is not suitable for interrupting load. The supply must be switched off before operating the moving carrier.

### FDBL4U

for Ø5 × 20/25 mm fuse

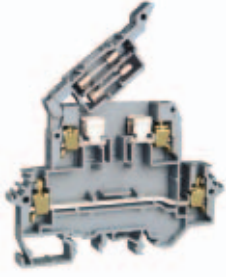

### FDBL4UE

for Ø5 × 20/25 mm fuse with indicator

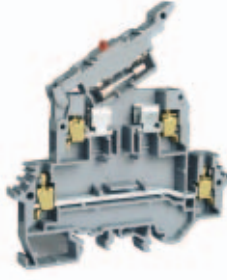

### FDBL4UE(LR)

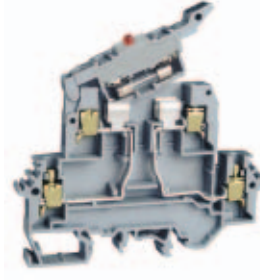

for Ø5 × 20/25 mm fuse with indicator

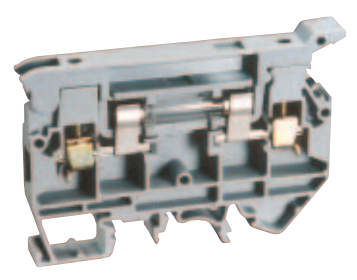

### FA4U

for Ø¼" × 1¼" fuse



FDBL4U			FDBL4UE			FDBL4UE(LR)			FA4U		
8 mm			8 mm			8 mm			9 mm		
66 x 88 mm			66 x 88 mm			66 x 88 mm			50 x 72 mm		
0.5 to 4 sq.mm 0.5 to 6 sq.mm			0.5 to 4 sq.mm 0.5 to 6 sq.mm			0.5 to 4 sq.mm 0.5 to 6 sq.mm			0.5 to 4 sq.mm 0.5 to 6 sq.mm		
9.5 mm			9.5 mm			9.5 mm			9.5 mm		
Polyamide 6.6			Polyamide 6.6			Polyamide 6.6			Polyamide 6.6		
4 screw clamps equipped with safety connection			4 screw clamps equipped with safety connection			4 screw clamps equipped with safety connection			2 screw clamps equipped with safety connection		
			24V AC, 24V DC, 48V AC, 48V DC, 110V AC, 110V DC, 220V AC			24V AC, 24V DC, 48V AC, 48V DC, 110V AC, 110V DC, 220V AC					
  	IEC Standard		  	IEC Standard		  	IEC Standard		  	CSA Standard	IEC Standard
22-12 AWG	0.5- 4 sq.mm	22-10 AWG	22-12 AWG	0.5- 4 sq.mm	22-10 AWG	22-12 AWG	0.5- 4 sq.mm	22-10 AWG	24-12 AWG	0.5-4 sq.mm	24-12 AWG
600 V	600 V	600 V	600 V	600 V	600 V	600 V	600 V	600 V	600 V	600 V	600 V
6.3 A 25 A	6.3 A 32 A	6.3 A 35 A	6.3 A 25 A	6.3 A 32 A	6.3 A 35 A	6.3 A 25 A	6.3 A 40 A	6.3 A 25 A	6.3 A	6.3 A	6.3 A
7 lb-in	0.5 Nm	7 lb-in	7 lb-in	0.5 Nm	7 lb-in	7 lb-in	0.5 Nm	7 lb-in	7 lb-in	0.5 Nm	7 lb-in
Type Cat No.	Std. Packing in Nos.	Wt Per unit in Grams	Type Cat No.	Std. Packing in Nos.	Wt Per unit in Grams	Type Cat No.	Std. Packing in Nos.	Wt Per unit in Grams	Type Cat No.	Std. Packing in Nos.	Wt Per unit in Grams
FDBL4U	20	26	FDBL4UE	20	27	FDBL4UE(LR)	20	27	FA4U	25	16.5
EPFDBL4U	25	5.2	EPFDBL4U	25	5.2	EPFDBL4U	25	5.2	EPFA4U	50	3.2
DIN 32G DIN 35U DIN 35-15D	50 M 50 M 50 M	750 360 700	DIN 32G DIN 35U DIN 35-15D	50 M 50 M 50 M	750 360 700	DIN 32G DIN 35U DIN 35-15D	50 M 50 M 50 M	750 360 700	DIN 32G DIN 35U DIN 35-15D	50 M 50 M 50 M	750 360 700
ES3S ES2N	100 50	7.0 7.4	ES3S ES2N	100 50	7.0 7.4	ES3S ES2N	100 50	7.0 7.4	ES3S ES2N	100 50	7.0 7.4
PASL8/2A PASL8/3A PASL8/4A PASL8/10A	10 10 10 10	2.2 3.2 3.9 11.5	PASL8/2A PASL8/3A PASL8/4A PASL8/10A	10 10 10 10	2.2 3.2 3.9 11.5	PASL8/2A PASL8/3A PASL8/4A PASL8/10A	10 10 10 10	2.2 3.2 3.9 11.5			
PSL08/2A PSL08/3A PSL08/4A PSL08/10A	100 100 100 100	0.5 0.9 1.35 3.25	PSL08/2A PSL08/3A PSL08/4A PSL08/10A	100 100 100 100	0.5 0.9 1.35 3.25	PSL08/2A PSL08/3A PSL08/4A PSL08/10A	100 100 100 100	0.5 0.9 1.35 3.25			
SS02	100	1.16	SS02	100	1.16	SS02	100	1.16			
RSL8A	100	0.51	RSL8A	100	0.51	RSL8A	100	0.51			
SL04	100	1.73	SL04	100	1.73	SL04	100	1.73			
CL8/2A CL8/3A CL8/4A CL8/10A	100 100 100 50	1.4 2.1 2.7 6.7	CL8/2A CL8/3A CL8/4A CL8/10A	100 100 100 50	1.4 2.1 2.7 6.7	CL8/2A CL8/3A CL8/4A CL8/10A	100 100 100 50	1.4 2.1 2.7 6.7	CL09/2 CL09/3 CL09/4 CL09/10	100 100 100 50	1.4 2.1 2.7 6.7
KM/8 KM/2	100 100	0.11 0.02	KM/8 KM/2	100 100	0.11 0.02	KM/8 KM/2	100 100	0.11 0.02	KM/9	100	0.12

**Important:** In all safety fuse link terminals the disconnecting device (moving carrier) is not suitable for interrupting load. The supply must be switched off before operating the moving carrier.

**Note :**

1. Across fuse circuit - 6.3 A
2. Left / Right side - 25 A

\* Cat No. for blown fuse indication with LED - FA4UL (24, 48, 110V AC, 24, 48, 110V DC, 220V AC)  
Cat No. for blown fuse indication with Neon Bulb - FA4UN (110V AC, 110V DC up to 300V AC)



# Safety Fuse Link Terminals

## F6U



Terminal Pitch	8 mm				
Height x Width	60 x 43 mm				
Connection Possibility	Stranded Wire	1.5 to 6 sq.mm			
	Solid Wire	1.5 to 10 sq.mm			
Stripping Length	9.5 mm				
Insulation Material	Polyamide 6.6				
Type of Connection	2 screw clamps equipped with safety connection				
# Fuse Size	5×20 / 5×25 mm				
Fusion Indication					
Approvals	CSA Standard	IEC Standard	UL Standard		
Rated Cross Section	22-8 AWG	1.5 - 6 sq.mm	22-8 AWG		
Voltage Rating	600 V	750 V	600 V		
Current Rating	6.3 A	6.3 A	6.3 A		
Torque	14 lb-in	0.8 Nm	14 lb-in		
	<b>Type Cat No.</b>	<b>Std. Packing in Nos.</b>	<b>Wt Per unit in Grams</b>		
Terminal Block (Prefix Type Cat. No. before Voltage Rating Fusion indication terminals)	F6U	50	20		
End Plate 	EPF6U	50			
Partition Plate 					
Mounting Rail 	DIN 32G DIN 35U DIN 35-15D	50 M 50 M 50 M	750 360 700		
End Clamp 	ES2N ES3N	50 50	7.4 7.6		
Insulated Comb Type Shorting Link 	2 way 3 way 4 way 10 way	CL08/2 CL08/3 CL08/4 CL08/10	100 100 100 50	1.4 2.1 2.8 7.0	
Marking Tags 	On Terminal On Fuse carrier	KM/8	100	0.12	
Fuse Current	0.1 A 0.5 A 0.63 A 1 A 2 A 3 A 4 A 5 A 6 A 6.3 A				
# Fuse Size 5 x 20 mm (CSFL4U Series) 1/4" 1 1/4" (CAFL4U Series)					

## Disconnect and Test Terminals

For measuring, control and regulatory circuits having utility instruments and associated transformers, the disconnect and test terminals provide clear functional advantage. Three versions are available:

- i) In DISCT6U disconnection is achieved by means of a sliding link operated with screw driver.

- ii) In KN4U disconnection is achieved by lifting hinged lever operating a knife contact.
- iii) In DISCTL4U disconnection is achieved by lifting hinged carrier having a tin plated brass link.

All screw terminals in DISCT6U, KN4U and DISCTL4U have special screw heads which accept test probes.

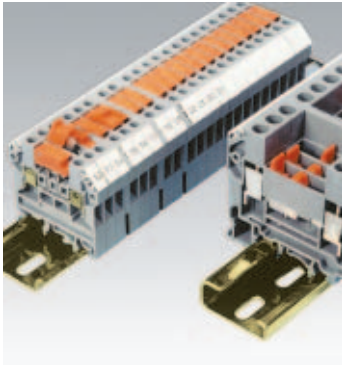

**KN4U**



**DISCT6U**

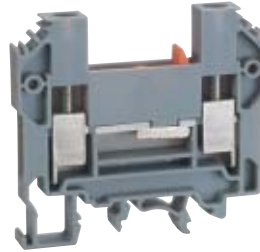

**DISCTL4U**



Terminal Pitch	6 mm			8 mm			8 mm			
Height x Width	46 X 46.3 mm			57 X 63 mm			43 X 58 mm			
Connection Possibility	Stranded Wire Solid Wire			1.5 to 6 sq.mm 1.5 to 10 sq.mm			0.5 to 4 sq.mm 0.5 to 4 sq.mm			
Stripping Length	9 mm			12 mm			9.5 mm			
Insulation Material	Polyamide 6.6			Polyamide 6.6			Polyamide 6.6			
Type of Connection	2 screw clamps connection			2 screw clamps connection			2 screw clamps equipped with disconnecting brass link			
Approvals										
Rated Cross Section	22-12 AWG	0.5-4 sq.mm	22-10 AWG	16-8 AWG	1.5-6 sq.mm	16-8 AWG	22-12 AWG	0.5-4 sq.mm	22-12 AWG	
Voltage Rating	600 V	750 V	600 V	600 V	750 V	600 V	600 V	750 V	600 V	
Current Rating	16 A	16 A	35 A	41 A	41 A	41 A	6.3 A	6.3 A	6.3 A	
Torque	7 lb-in	0.5 Nm	7 lb-in	14 lb-in	1.2 Nm	14 lb-in	7 lb-in	0.5Nm	7 lb-in	
	Type Cat No.	Std. Packing in Nos.	Wt Per unit in Grams	Type Cat No.	Std. Packing in Nos.	Wt Per unit in Grams	Type Cat No.	Std. Packing in Nos.	Wt Per unit in Grams	
Terminal Station	KN4U	50	11	DISCT6U	50	28	DISCTL4U	100	15	
End Plate	EPKN4U	50	2	EPDISCT6U	50	3.9	EPF4U	50	2.2	
Partition Plate							PPF4U	50	4.1	
Mounting Rail		DIN 32G	50 M	750	DIN 32G	50 M	750	DIN 32G	50 M	750
		DIN 35U	50 M	360	DIN 35U	50 M	360	DIN 35U	50 M	360
		DIN 35-15D	50 M	700	DIN 35-15D	50 M	700	DIN 35-15D	50 M	700
End Clamp		ES1S	50	15.3	ES1S	50	15.3	ES1S	50	15.3
		ES2S	50	15.1	ES2S	50	15.1	ES2S	50	15.1
		ES3S	50	7.0	ES3S	50	7.0	ES3S	50	7.0
		ES2N	50	7.4	ES2N	50	7.4	ES2N	50	7.4
		ES3N	50	4.5	ES3N	50	4.5	ES3N	50	4.5
Comb Link		CL6/2A	100	1.1	CL08/2	100	1.4	CL8/2A	100	1.4
	2 way	CL6/3A	100	1.7	CL08/3	100	2.1	CL8/3A	100	2.1
	3 way	CL6/4A	100	2.3	CL08/4	100	2.8	CL8/4A	100	2.7
	4 way	CL6/10A	50	5.6	CL08/10	50	7.0	CL8/10A	50	6.7
	10 way									
Marking Tags		(K Type) KM/6	100	0.11	KM/8	100	0.11	KM/8 KM/2	100	0.11 0.02

**Important:** The above terminals are not suitable for interrupting load. The supply must be switched off before operating the slide link or lifting the lever or moving the hinged carrier.

## Disconnect and Test Terminals

### DISCT6US

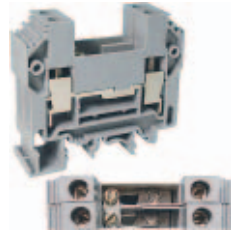







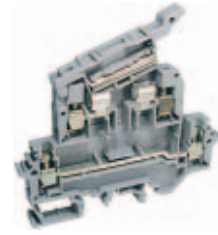

### DISCTL6U



### DBLDISCTL4U

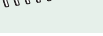

Terminal Pitch	16 mm			8 mm			8 mm			
Height x Width	57 x 63 mm			60 x 43 mm			66 x 88 mm			
Connection Possibility	Stranded Wire Solid Wire			1.5 to 6 sq.mm 1.5 to 10 sq.mm			1.5 to 6 sq.mm 1.5 to 10 sq.mm			
Stripping Length	12 mm			9.5 mm			9.5 mm			
Insulation Material	Polyamide 6.6			Polyamide 6.6			Polyamide 6.6			
Type of Connection	4 screw clamps connection, internally shorted			2 screw clamps equipped with disconnecting brass link			4 screw clamps and 1 tapped hole for cross connection			
Approvals	CSA Standard	IEC Standard	UL Standard	CSA Standard	IEC Standard	UL Standard	CSA Standard	IEC Standard	UL Standard	
Rated Cross Section	16-8 AWG	1.5-16 sq.mm	16-8 AWG	22-8 AWG	1.5 - 6 sq.mm	22-8 AWG	22-12 AWG	0.5-4 sq.mm	22-12 AWG	
Voltage Rating	300 V	300 V	300 V	600 V	750 V	600 V	300 V	750 V	300 V	
Current Rating	10 A	10 A	10 A	6.3 A	6.3 A	6.3 A	20 A	24 A	20 A	
Torque	14 lb-in	1.2 Nm	14 lb-in	14 lb-in	0.8 Nm	14 lb-in	7 lb-in	0.4 Nm	7 lb-in	
	Type Cat No.	Std. Packing in Nos.	Wt Per unit in Grams	Type Cat No.	Std. Packing in Nos.	Wt Per unit in Grams	Type Cat No.	Std. Packing in Nos.	Wt Per unit in Grams	
Terminal Block	DISCT6US	20	52	DISCTL6U	50	22	DBLDISCTL4U	20	26	
End Plate 	EPDISCT6U	50	3.9	EPF6U	50	4	EPFDBL4U	25	5.2	
Partition Plate 				PPDISCTL6U	50	5				
Separator Plate 										
Mounting Rail 	DIN 32G DIN 35U DIN 35-15D	50 M 50 M 50 M	750 360 700	DIN 32G DIN 35U DIN 35-15D	50 M 50 M 50 M	750 360 700	DIN 32G DIN 35U DIN 35-15D	50 M 50 M 50 M	750 360 700	
End Clamp 	ES2N ES3N	50 50	7.4 4.5	ES2N ES3N	50 50	7.4 7.6	ES2N ES3N	50 50	7.4 7.6	
Insulated Comb 	CL08/2 CL08/3 CL08/4 CL08/10	100 100 100 50	1.4 2.1 2.8 7.0	CL08/2 CL08/3 CL08/4 CL08/10	100 100 100 50	1.4 2.1 2.8 7.0	CL8/2A CL8/3A CL8/4A CL8/10A	100 100 100 50	1.4 2.1 2.8 7.0	
Type Shorting Link 										
Marking Tags 	On Terminal On carrier	KM/8	100	0.11	KM/8	100	0.12	KM/8 KM/2	100 100	0.12

For other shorting / interconnecting accessories, refer Double Level Safety Fuse Link terminals

*Important: The above terminals are not suitable for interrupting load. The supply must be switched off before operating the slide link or lifting the lever or moving the hinged carrier.*

## Tab Connection Terminals

The TAB4U tab connection terminals offer quick connection possibility, using standard 'Fast On' type lugs.

Connection is achieved by pushing lug onto the tab blade of terminal block. The terminal housing is so designed that the wall protrudes beyond tab blades.

In order to provide a reliable connection, recommended lugs are to be used with TAB4U terminals.

The design facilitates cross connection between adjacent terminal.

The SCRW4UTAB terminal is standard screw clamp, feed through terminal block with a tab connection at centre for suitable "Fast On" type lugs.

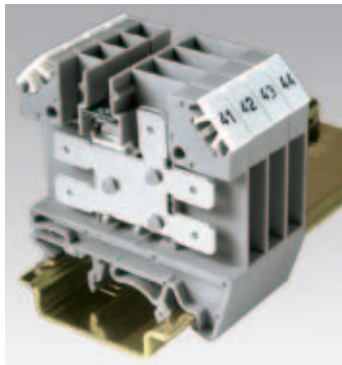









**TAB4U**

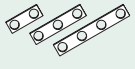

**SCRW4UTAB**



Terminal Pitch	6 mm			6 mm		
Height x Width	49.5 x 47 mm			45 x 43 mm		
Connection Possibility	0.5 to 4 sq. mm			0.5 to 4 sq.mm 0.5 to 6 sq.mm		
Stripping Length	9 mm			9 mm		
Insulation Material	Polyamide 6.6			Polyamide 6.6		
Type of Connection	5 tab connection points and 1 tapped hole for cross connection			2 screw clamps and 1 tab connection at the centre		
Approvals						
Rated Cross Section	22-12 AWG	0.5-4 sq.mm	22-12 AWG	22-12 AWG	0.5 - 4 sq.mm	22-12 AWG
Voltage Rating	300 V	250 V	300 V	300 V	500 V	300 V
Current Rating	25 A	32 A	25 A	25 A	32 A	25 A
Tab Blade Size (mm)	*6.3 x 0.8	6.3 x 0.8	6.3 x 0.8	2.4 x 0.8	2.4 x 0.8	2.4 x 0.8
Torque				7 lb-in	0.5 Nm	7 lb-in
	<b>Type Cat No.</b>	<b>Std. Packing in No.</b>	<b>Wt Per unit in Grams</b>	<b>Type Cat No.</b>	<b>Std. Packing in Nos.</b>	<b>Wt Per unit in Grams</b>
Terminal Station	TAB4U	100	7.8	SCRW4UTAB	100	8
End Plate 	EPTAB4U	50	2.1	EPSCRW2.5U/4U	50	2.3
Partition Plate 				PPSCRW2.5U/4U	50	2
Mounting Rail 	DIN 32G DIN 35U DIN 35-15U	50 M 50 M 50 M	750 360 700	DIN 32G DIN 35U DIN 35-15U	50 M 50 M 50 M	750 360 700
End Clamp** 	ES3S ES2N	100 50	7.0 7.4	ES3S ES2N	100 50	7.0 7.4
Permanent Shorting Links 	2 way 3 way 4 way 10 way	PSL06/2 PSL06/3 PSL06/4 PSL06/10	100 100 100 100			
Short Sleeve for quick Permanent Shorting 		SS06	100			1.16
Removable Shorting Link 		RSL6	100			0.25
Comb Link 	2 way 3 way 4 way 10 way			CL6/2 CL6/3 CL6/4 CL6/10	100 100 100 50	1.2 1.8 2.4 6.0
Marking Tags (K Type) 		KM/6	100		KM/6	100
			0.1			0.1

\*\*Other End Clamps, ES1S, ES2S and ES3N can also be used.

\* Recommended Lugs: AMP 42844:1 or equivalent.

## Clip Connection Terminal Blocks





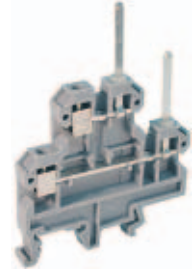

SCRW4UCLIP and DBL4UCLIP are terminals for Clip Connection (solderless) according to DIN 41611-Part-4. Three wires (0.5 sq.mm) can be connected with clip on to the pin by using special tool. In order to provide a reliable connection, attention must be paid to the size of the clip suitable for pin of size 0.8 x 1.6 mm

### SCRW4UCLIP



### DBL4UCLIP

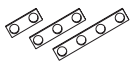

Terminal Pitch	6 mm			6 mm		
Height x Width	67 x 43 mm			84 x 55.5 mm		
Stripping Length	9 mm			9 mm		
Insulation Material	Polyamide 6.6			Polyamide 6.6		
Type of Connection	1 screw connection and 1 blade for 3 (0.5 sq.mm) connection			2 screw connections and 2 blades for 6 (0.5 sq.mm) connection		
Approvals	CSA Standard	IEC Standard	UL Standard	CSA Standard	IEC Standard	UL Standard
Rated Cross Section	22-12AWG	0.5-4sq.mm	22-12AWG	22-12AWG	0.5-4sq.mm	22-12AWG
Voltage Rating	300 V	250 V	300 V	300 V	250 V	300 V
Current Rating	10 A	10 A	10 A	10 A	10 A	10 A
Tab Blade Size (mm)	2.4 x 0.8 mm			2.4 x 0.8 mm		
	Type Cat No.	Std. Packing in Nos.	Wt Per unit in Grams	Type Cat No.	Std. Packing in Nos.	Wt Per unit in Grams
Terminal Station	SCRW4UCLIP	100	8.0	DBL4UCLIP	50	15
End Plate 	EPSCRW2.5U/4U	50	1.7	EPDBL4U	50	2.5
Mounting Rail 	DIN 32G DIN 35U DIN 35-15D	50 M 50 M 50 M	750 360 700	DIN 32G DIN 35U DIN 35-15D	50 M 50 M 50 M	750 360 700
End Clamp 	ES2N ES3N	50 50	7.4 4.5	ES2N ES3N	50 50	7.4 4.5
Pre Assembled Shorting Links 	2 way 3 way 4 way 10 way	PASL06/2 PASL06/3 PASL06/4 PASL06/10	100 50 50 10	PASL6/2A PASL6/3A PASL6/4A PASL6/10A	100 50 50 10	1.1 1.25 1.5 9.5
Insulated Pre Assembled Shorting Link 	2 way 3 way 4 way 10 way	PASLN06/2 PASLN06/3 PASLN06/4 PASLN06/10	100 50 50 10	PASLN6/2A PASLN6/3A PASLN6/4A PASLN6/10A	100 50 50 10	
Permanent Shorting Links 	2 way 3 way 4 way 10 way	PSL06/2 PSL06/3 PSL06/4 PSL06/10	100 100 100 100	PSL06/2 PSL06/3 PSL06/4 PSL06/10	100 100 100 100	0.3 0.5 0.7 1.7
Short Sleeve & Screw for Quick Permanent Shorting 		SS02	100	SS01	100	0.7
Insulated Comb Type Shorting Link 	2 way 3 way 4 way 10 way	CL6/2 CL6/3 CL6/4 CL6/10	100 100 100 50	CL6/2B CL6/3B CL6/4B CL6/10B	100 100 100 50	1.2 1.8 2.4 6.0
Marking Tags (K Type) Continuous 90mm Strip 		KM/6 KM/9F	100 10	KM/2	100	0.07 0.02

## Terminals with Electronic Components

In various applications where input signals have to be converted and indications are required or circuit protection is called for, use of terminals with electronic components is recommended. For such applications, different terminals incorporating specific components are offered. Based on customer requirements, specially assembled terminals can also be offered.

DBL4UO - double level terminals with open current bar at bottom level with extra drilled hole can accommodate electronic components like diodes, resistors, LEDs etc. as per the application.

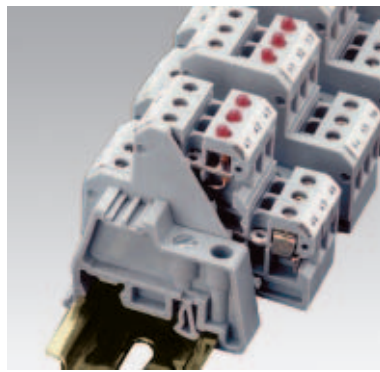

Type	DBL4UED1/D2			DBL4UED3		
Voltage	300 V ~			300 V ~		
Diode	1N 4007			1N 4007		
Diode Reverse Voltage	1000 V			1000 V		
Diode Current	1 A			1 A		
Connection Possibility	Stranded Wire	0.5 to 4 sq.mm		Stranded Wire	0.5 to 4 sq.mm	
	Solid Wire	0.5 to 6 sq.mm		Solid Wire	0.5 to 6 sq.mm	
Stripping Length	9 mm			9 mm		
Terminal Dimension	H x W x T (mm)			54 x 55.5 x 6		
Approvals						
Rated Cross Section	22-12 AWG	0.5-4 sq.mm	22-10 AWG	22-12 AWG	0.5-4 sq.mm	22-10 AWG
Voltage Rating	600 V	400 V	600 V	600 V	400 V	600 V
Current Rating	25 A	32 A	25 A	25 A	32 A	25 A
Torque	7 lb-in	0.5 Nm	7 lb-in	7 lb-in	0.5 Nm	7 lb-in
	<b>Type Cat No.</b>	<b>Std. Packing in Nos.</b>	<b>Wt Per unit in Grams</b>	<b>Type Cat No.</b>	<b>Std. Packing in Nos.</b>	<b>Wt Per unit in Grams</b>
Terminal Station	DBL4UED1	100	13	DBL4UED3	100	13
	DBL4UED2	100	13			
End Plate	EPDBL4U	50	2.5	EPDBL4U	50	2.5
Mounting Rail	DIN 32G	50 M	750	DIN 32G	50 M	750
	DIN 35U	50 M	360	DIN 35U	50 M	360
	DIN 35-15D	50 M	700	DIN 35-15D	50 M	700
Permanent Shorting Link	2 way	100	0.3	PSL06/2	100	0.3
	3 way	100	0.5	PSL06/3	100	0.5
	4 way	100	0.7	PSL06/4	100	0.7
	10 way	100	1.9	PASL/10A	100	1.9
Short Sleeve for quick permanent shorting	SS01	100	0.7	SS01	100	0.7
Marking Tags (K Type)	KM/2	100	0.02	KM/2	100	0.02

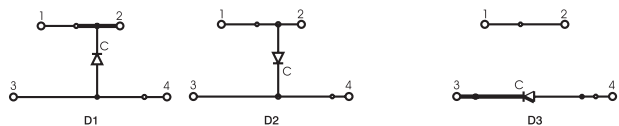

- One connector with 4 clamps on 2 levels equipped with anti return diode .
  - Shorting possibility for adjacent terminals on both levels.
- # In DBL4UED1, cathode of anti return diode is connected on the upper level.  
# In DBL4UED2, cathode of anti return diode is connected on the lower level.

- One connector with 4 clamps on 2 levels equipped with diode (cathode on either side) on lower level.
- Shorting possibility for adjacent terminals on both levels.

### DBL4UEDD1/DD2

(Diode circuit for lamp testing)

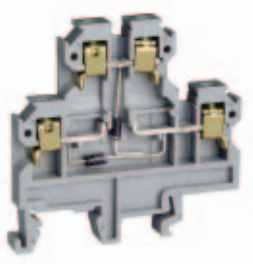

### DBL4UEDD3/DD4

(Diode circuit for lamp testing)

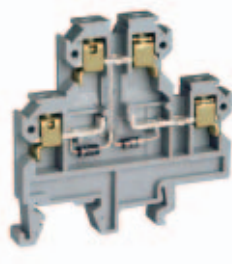

### DBL4UED4

(Diode circuit for lamp testing)

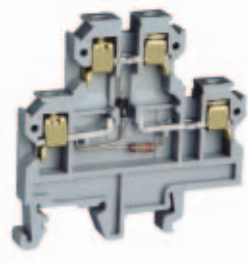

### DBL4UEDD5

(Diode circuit for lamp testing)



DD1/DD2  
300 V ~

1N 4007

1000 V

1 A

0.5 to 4 sq.mm  
0.5 to 4 sq.mm

9 mm

54 x 55.5 x 6



22-12 AWG 0.5-4 sq.mm 22-10 AWG

600 V 400 V 600 V

25 A 32 A 25 A

7 lb-in 0.5 Nm 7 lb-in

Type Cat No.	Std. Packing in Nos.	Wt Per unit in Grams
DBL4UEDD1	100	13
DBL4UEDD2	100	13
EPDBL4U	50	2.5
DIN 32G	50 M	750
DIN 35U	50 M	360
DIN 35-15D	50 M	700
PSL06/2	100	0.3
PSL06/3	100	0.5
PSL06/4	100	0.7
PASL/10A	100	1.9
SS01	100	0.7
KM/2	100	0.02

DD3/DD4  
300 V ~

1N 4007

1000 V

1 A

0.5 to 4 sq.mm  
0.5 to 6 sq.mm

9 mm

54 x 55.5 x 6



22-12 AWG 0.5-4 sq.mm 22-10 AWG

600 V 400 V 600 V

25 A 32 A 25 A

7 lb-in 0.5 Nm 7 lb-in

Type Cat No.	Std. Packing in Nos.	Wt Per unit in Grams
DBL4UE DD3	100	13
DBL4UE DD4	100	13
EPDBL4U	50	2.5
DIN 32G	50 M	750
DIN 35U	50 M	360
DIN 35-15D	50 M	700
PSL06/2	100	0.3
PSL06/3	100	0.5
PSL06/4	100	0.7
PASL/10A	100	1.9
SS01	100	0.7
KM/2	100	0.02

D4  
12 V -, 24 V -

1N 4007

1000 V

1 A

0.5 to 4 sq.mm  
0.5 to 6 sq.mm

9 mm

54 x 55.5 x 6



22-12 AWG 0.5-4 sq.mm 22-10 AWG

600 V 400 V 600 V

25 A 32 A 25 A

7 lb-in 0.5 Nm 7 lb-in

Type Cat No.	Std. Packing in Nos.	Wt Per unit in Grams
DBL4UED4	100	13
EPDBL4U	50	2.5
DIN 32G	50 M	750
DIN 35U	50 M	360
DIN 35-15D	50 M	700
PSL06/2	100	0.3
PSL06/3	100	0.5
PSL06/4	100	0.7
PASL/10A	100	1.9
SS01	100	0.7
KM/2	100	0.02

DD5  
12 V ~, 24 V ~

1N 4007

1000 V

1 A

0.5 to 4 sq.mm  
0.5 to 6 sq.mm

9 mm

54 x 55.5 x 6



22-12 AWG 0.5-4 sq.mm 22-10 AWG

600 V 400 V 600 V

25 A 32 A 25 A

7 lb-in 0.5 Nm 7 lb-in

Type Cat No.	Std. Packing in Nos.	Wt Per unit in Grams
DBL4UEDD5	100	13
EPDBL4U	50	2.5
DIN 32G	50 M	750
DIN 35U	50 M	360
DIN 35-15D	50 M	700
PSL06/2	100	0.3
PSL06/3	100	0.5
PSL06/4	100	0.7
PASL/10A	100	1.9
SS01	100	0.7
KM/2	100	0.02

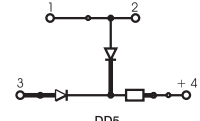
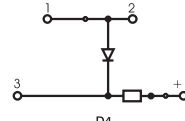
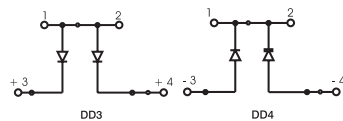
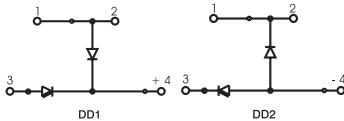

- One connector with 4 clamps on 2 levels.
- Shorting possibility for adjacent terminals on both levels.
- # In DBL4UEDD1, one +ve output on the lower level.
- # In DBL4UEDD2, one -ve output on the lower level.

- One connector with 4 clamps on 2 levels.
- Shorting possibility for adjacent terminals on both levels.
- # In DBL4UEDD3, two +ve output on the lower level.
- # In DBL4UEDD4, two -ve output on the lower level.

- One +ve output on lower level
- One connector with 4 clamps on 2 levels.
- Shorting possibility for adjacent terminals on both levels.

- One +ve output on lower level
- One connector with 4 clamps on 2 levels.
- Shorting possibility for adjacent terminals on both levels.



### DBL4UELD3

(A.C / D.C Voltage indicator with LED)

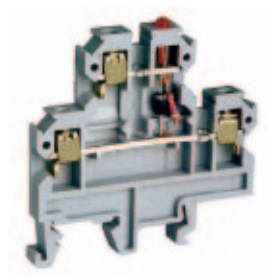

### DBL4UELD4

(A.C / D.C Voltage indicator with LED)

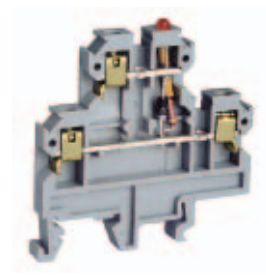

### DBL4UELD5

(A.C Voltage indicator with LED)

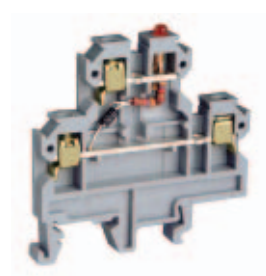

Type	LD3			LD4			LD5			
Voltage	12V AC, 12V DC, 24V AC, 24V DC			24V AC, 24V DC, 48V AC, 48V DC			24V AC, 48V AC, 110V AC, 220V AC			
Diode	1N 4007			1N 4007			1N 4007			
Diode Reverse Voltage										
Diode Current										
Connection Possibility	Stranded Wire Solid Wire			0.5 to 4 sq.mm 0.5 to 6 sq.mm			0.5 to 4 sq.mm 0.5 to 6 sq.mm			
Stripping Length	9 mm			9 mm			9 mm			
Terminal Dimension H x W x T (mm)	54 x 55.5 x 6			54 x 55.5 x 6			54 x 55.5 x 6			
Approvals										
Rated Cross Section	22-12 AWG	0.5-4 sq.mm	22-10 AWG	22-12 AWG	0.5-4 sq.mm	22-10 AWG	22-12 AWG	0.5-4 sq.mm	22-10 AWG	
Voltage Rating	600 V		600 V	600 V		600 V	600 V		600 V	
Current Rating	25 A	32 A	25 A	25 A	32 A	25 A	25 A	32 A	25 A	
Torque	7 lb-in	0.5 Nm	7 lb-in	7 lb-in	0.5 Nm	7 lb-in	7 lb-in	0.5 Nm	7 lb-in	
	Type Cat No.	Std. Packing in Nos.	Wt Per unit in Grams	Type Cat No.	Std. Packing in Nos.	Wt Per unit in Grams	Type Cat No.	Std. Packing in Nos.	Wt Per unit in Grams	
Terminal Station	DBL4UELD3	50	13	DBL4UELD4	50	13	DBL4UELD5	50	13	
End Plate	EPDBL4U	50	2.5	EPDBL4U	50	2.5	EPDBL4U	50	2.5	
Mounting Rail	DIN 32G DIN 35U DIN 35-15D	50 M 50 M 50 M	750 360 700	DIN 32G DIN 35U DIN 35-15D	50 M 50 M 50 M	750 360 700	DIN 32G DIN 35U DIN 35-15D	50 M 50 M 50 M	750 360 700	
Permanent Shorting Link	2 way 3 way 4 way 10 way	PSL06/2 PSL06/3 PSL06/4 PASL/10A	100 100 100 100	0.3 0.5 0.7 1.9	PSL06/2 PSL06/3 PSL06/4 PASL/10A	100 100 100 100	0.3 0.5 0.7 1.9	PSL06/2 PSL06/3 PSL06/4 PASL/10A	100 100 100 100	0.3 0.5 0.7 1.9
Short Sleeve for quick permanent shorting	SS01	100	0.7	SS01	100	0.7	SS01	100	0.7	
Marking Tags (K Type)	KM/2	100	0.02	KM/2	100	0.02	KM/2	100	0.02	

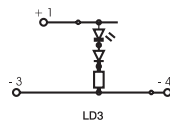

LD3

- ve on lower level
- One connector with 3 clamps on 2 levels equipped with protected LED.
- Shorting possibility for adjacent terminals on both levels.

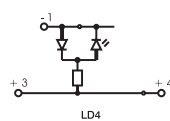

LD4

- +ve on lower level
- One connector with 3 clamps on 2 levels equipped with protected LED.
- Shorting possibility for adjacent terminals on both levels.

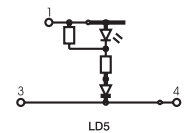

LD5

- One connector with 3 clamps on 2 levels.
- Shorting possibility for adjacent terminals on both levels.



### DBL4UEN1

(A.C Voltage indicator with Neon lamp)

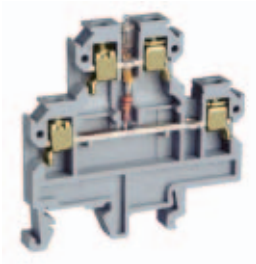

N1  
110V AC to 220V AC

### DBL4UELD1/LD2

(D.C Voltage indicator with LED)

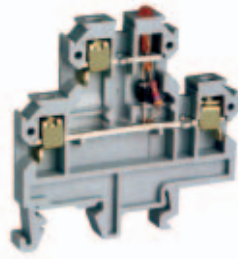

LD1 / LD2  
24V AC

1N 4007

### DBL4UEL1/L2

(D.C Voltage indicator with LED)

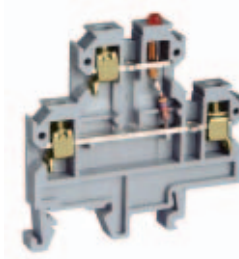

L1/L2  
6V AC, 24V AC, 60V AC

1N 4007

### DBL4UO

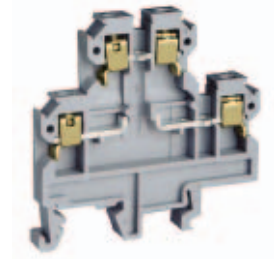

DBL4UO

0.5 to 4 sq.mm  
0.5 to 4 sq.mm

9 mm

54 x 55.5 x 6



22-12 AWG 0.5-4 sq.mm 22-10 AWG

600 V

600 V

25 A

32 A

25 A

7 lb-in

0.5 Nm

7 lb-in

Type  
Cat No.

Std. Packing  
in Nos.

Wt Per unit  
in Grams

DBL4UEN1

50

13

0.5 to 4 sq.mm  
0.5 to 4 sq.mm

9 mm

54 x 55.5 x 6



22-12 AWG 0.5-4 sq.mm 22-10 AWG

600 V

600 V

25 A

32 A

25 A

7 lb-in

0.5 Nm

7 lb-in

Type  
Cat No.

Std. Packing  
in Nos.

Wt Per unit  
in Grams

#DBL4UELD1

50

13

#DBL4UELD2

50

13

EPDBL4U

50

2.5

DIN 32G

50 M

750

DIN 35U

50 M

360

DIN 35-15D

50 M

700

PSL06/2

100

0.3

PSL06/3

100

0.5

PSL06/4

100

0.7

PASL/10A

100

1.9

SS01

100

0.7

KM/2

100

0.02

0.5 to 4 sq.mm  
0.5 to 4 sq.mm

9 mm

54 x 55.5 x 6



22-12 AWG 0.5-4 sq.mm 22-10 AWG

600 V

600 V

25 A

32 A

25 A

7 lb-in

0.5 Nm

7 lb-in

Type  
Cat No.

Std. Packing  
in Nos.

Wt Per unit  
in Grams

#DBL4UEL1

50

13

#DBL4UEL2

50

13

EPDBL4U

50

2.5

DIN 32G

50 M

750

DIN 35U

50 M

360

DIN 35-15D

50 M

700

PSL06/2

100

0.3

PSL06/3

100

0.5

PSL06/4

100

0.7

PASL/10A

100

1.9

SS01

100

0.7

KM/2

100

0.02

0.5 to 4 sq.mm  
0.5 to 4 sq.mm

9 mm

54 x 55.5 x 6



22-12 AWG 0.5-4 sq.mm 22-10 AWG

600 V

400 V

600 V

25 A

32 A

25 A

7 lb-in

0.5 Nm

7 lb-in

Type  
Cat No.

Std. Packing  
in Nos.

Wt Per unit  
in Grams

DBL4UO

100

13

EPDBL4U

50

2.5

DIN 32G

50 M

750

DIN 35U

50 M

360

DIN 35-15D

50 M

700

PSL06/2

100

0.3

PSL06/3

100

0.5

PSL06/4

100

0.7

PASL/10A

100

1.9

SS01

100

0.7

KM/2

100

0.02

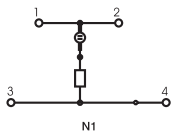

N1

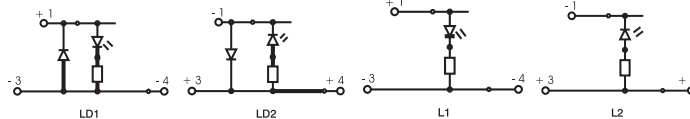

LD1

LD2

L1

L2

- One terminal with 4 clamps on 2 levels.
- Shorting possibility for adjacent terminals on lower level.

- One terminal with 3 clamps on 2 levels equipped with protected LED and protection for associated circuit at the output side.

• **Caution** : Reversal of polarity may damage the source.  
# In DBL4UELD1, -ve on the lower level.  
# In DBL4UELD2, +ve on the lower level.

- One terminal with 3 clamps on 2 levels with non protected LED.
- Shorting possibility for adjacent terminals on both levels.

# In DBL4UEL1, -ve on the lower level.  
# In DBL4UEL2, +ve on the lower level.

## Printed Circuit Board Modular Terminals

The modular PCB terminals are designed for mounting on PCBs with 5mm, 7.5mm and 11mm hole pitch. For 7.5 mm hole pitch, individual PCB5/PCB5 should be fitted with end plate.

The terminals have marker holding recess to accept international "K" type marking tags.

Special Features of PCB Series Terminals are

- Terminals can be interlocked to achieve multipole connections
- PCB5 terminals are available in different mounting to suit horizontal, Angular (45°) and vertical entry of wire.
- PCB5 and PCB7.5 terminals for two pin mounting/ connection provide extra support in mounting.

PCBDBL11 terminals besides offering extra support for mounting, facilitate higher density of wiring by double level connections. A PCBDBL11 terminal block offers 4 pin mounting and termination of 4 wires.

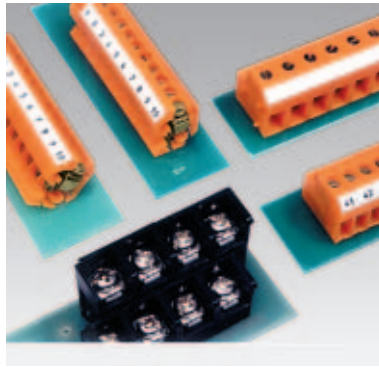

### PCBM5H



### PCBM5A

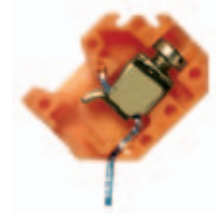

Terminal Pitch	5 mm			5 mm		
Height x Width	19 x 14.5 mm			17 x 22 mm		
Connection Possibility	Stranded Wire Solid Wire			Upto 2.5 sq.mm Upto 2.5 sq.mm		
Stripping Length	7 mm			7 mm		
Insulation Material	Polyamide 6.6			Polyamide 6.6		
Type of Connection	1 screw clamp and 1 solder pin			1 screw clamp and 1 solder pin		
Approvals	  			  		
Rated Cross Section	22-14 AWG	0.5-2.5 sq.mm	22-14 AWG	22-14 AWG	0.5-2.5 sq.mm	22-14 AWG
Voltage Rating	300 V	250 V	300 V	300 V	250 V	300 V
Current Rating	16 A	16 A	16 A	16 A	16 A	16 A
Torque	7 lb-in	0.4 Nm	7 lb-in	7 lb-in	0.4 Nm	7 lb-in
	<b>Type Cat No.</b>	<b>Std. Packing in Nos.</b>	<b>Wt Per unit in Grams</b>	<b>Type Cat No.</b>	<b>Std. Packing in Nos.</b>	<b>Wt Per unit in Grams</b>
Terminal Station	PCBM5H	50	1.8	PCBM5A	50	1.8
End Plate / Spacer	EPPCB	50	0.2	EPPCB	50	0.2
Marking Tag	KM/4	100	0.01	KM/4	100	0.01

**PCBM5V**

**PCB5**

**PCB7.5**

**PCBDBL11**

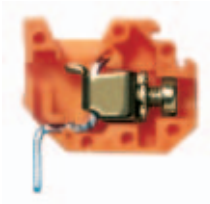

5 mm			5 mm			7.5 mm			11 mm		
14.5 x 19 mm			18 x 19 mm			19 x 19 mm			28 x 22 mm		
Upto 2.5 sq. mm Upto 2.5 sq. mm			Upto 2.5 sq. mm Upto 0.5 to 4 sq. mm			Upto 2.5 sq. mm Upto 0.5-4 sq. mm			Upto 2.5 sq. mm		
7 mm			7 mm			9 mm			20 mm		
Polyamide 6.6			Polyamide 6.6			Polyamide 6.6			Polyamide 6.6		
1 screw clamp and 1 solder pin			1 screw clamp and 2 solder pins			1 screw clamp and 2 solder pins			4 screw clamps and 4 solder pins		
22-14 AWG	0.5-2.5 sq.mm	22-14 AWG	22-14 AWG	0.5-2.5 sq.mm	22-14 AWG	22-14 AWG	0.5-2.5 sq.mm	22-14 AWG	22-12 AWG	0.5-2.5 sq.mm	22-12 AWG
300 V	250 V	300 V	300 V	250 V	300 V	300 V	450 V	300 V	300 V	300 V	300 V
16 A	16 A	16 A	18 A	18 A	**18 A	18 A	18 A	**18 A	25 A	24 A	**25 A
7 lb-in	0.4 Nm	7 lb-in	7 lb-in	0.4 Nm	7 lb-in	7 lb-in	0.5 Nm	7 lb-in	7 lb-in	1.2 Nm	14 lb-in
<b>Type Cat No.</b>	<b>Std. Packing in Nos.</b>	<b>Wt Per unit in Grams</b>	<b>Type Cat No.</b>	<b>Std. Packing in Nos.</b>	<b>Wt Per unit in Grams</b>	<b>Type Cat No.</b>	<b>Std. Packing in Nos.</b>	<b>Wt Per unit in Grams</b>	<b>Type Cat No.</b>	<b>Std. Packing in Nos.</b>	<b>Wt Per unit in Grams</b>
PCBM5V	50	1.8	PCB5	50	2.4	PCB7.5	50	3.7	PCBDBL11	50	16
EPPCB	50	0.2	ESPCB	50	0.3						
KM/4	100	0.01	KM/4	100	0.01	KM/7.5	100	0.1			

## Limited VA rating of 10 A maximum at 300 V for General Industrial use.

## High Current, Feed-Through Screw Clamp Terminals

Universal mounting, feed-through terminal blocks for wires of large cross section and high current application provide gas tight and reliable electrical connection with very low contact resistance.

The specially designed slot in the terminal block feet can be used for mounting and dismounting from the rail with the help of a screw driver.

The terminal has marker holding recess to accept international 'K' type and group marker.



### SCRW50U

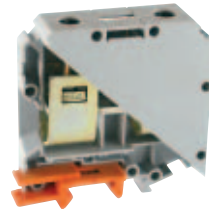

### SCRW95U

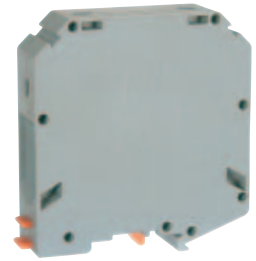

Terminal Pitch	20.5 mm			25 mm		
Height x Width	75.5 x 71 mm			90 x 83 mm		
Connection Possibility	Stranded Wire Solid Wire			16 to 95 sq.mm 16 to 120 sq.mm		
Stripping Length	22 mm			24 mm		
Insulation Material	Polyamide 6.6			Polyamide 6.6		
Type of Connection	2 screw clamps connection			2 Grub screw clamps connection		
Approvals *	CSA Standard	CE	UL US	CSA Standard	CE	UL US
Rated Cross Section	2/0 -6 AWG	16-50sq.mm	2/0 -6 AWG	4/0 -2 A.WG	16 - 95 sq.mm	4/0 -2 AWG
Voltage Rating	600 V	1000 V	600 V	600 V	1000 V	600 V
Current Rating	150 A	150 A	150 A	230 A	232 A	230 A
Torque	60 lb-in	6.8 Nm	60 lb-in	160 lb-in	18.2 Nm	160 lb-in
	<b>Type Cat No.</b>	<b>Std. Packing in Nos.</b>	<b>Wt Per unit in Grams</b>	<b>Type Cat No.</b>	<b>Std. Packing in Nos.</b>	<b>Wt Per unit in Grams</b>
Terminal Station	SCRW50U	20	120	SCRW95U	10	210
Mounting Rail	DIN 32G	50 M	750	DIN 32G	50 M	750
	DIN 35U	50 M	360	DIN 35U	50 M	360
	DIN 35-15D	50 M	700	DIN 35-15D	50 M	700
End Clamp	ES3S	100	7.0	ES3S	100	7.0
	ES2N	50	7.4	ES2N	50	7.4
Marking Tags (K Type)	KM/50	100	0.1	KM/95	100	0.1
Group Marker (K Type)	KM/G2	100	0.1	KM/G2	100	0.1

\* Proposed ratings as per CSA standards.

## Active Terminal Blocks

The active terminals blocks are with built-in electronic components for surge protection. These terminals are used in applications where circuit protection against transient over voltage is required.

The terminals are designed to protect a single line against longitudinal (line / earth) surges, thereby protecting the distribution.

DBL4UERES - Single changeover relay terminal is used for switching loads in PLC application.

Note :

- DBL4UESDU - For DC applications.
- DBL4UESDB - For AC applications.  
A - Anode  
K - Cathode
- SDUX - 48 V , 3.2 A, 400 V AC is available in SDUB type at current rating 4A.

DBL4USP - spacer can be used for covering custom electronic components, which may protrude outside the DBL4UO terminal block.

Please refer for terminals with custom specified surge suppression requirement.

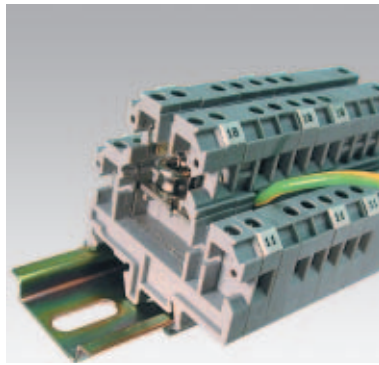



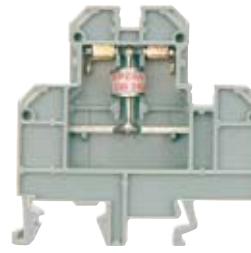

**DBL4UELA**



**DBL4UE3LA**



Terminal Pitch	12 mm			12 mm		
Height x Width	54 x 55.5 mm			54 x 55.5 mm		
Stripping Length	9 mm			9 mm		
Insulation Material	Polyamide 6.6			Polyamide 6.6		
Type of Connection	4 Screw Clamps			4 Screw Clamps		
Wire Range	0.5 - 4 sq.mm / 22-10 AWG			0.5 - 4 sq.mm / 22-10 AWG		
Voltage Rating	75 V, 90 V, 240 V, 600 V, 1000 V DC			90 V, 250 V, 350 V, 450 V DC		
Impulse Discharge Current	20 KA (8/20µs)			10 KA (8/20µs)		
Alternating Discharge Current at 50 Hz	20 A			10 A		
Response Time	100 ns			100 ns		
Normal Current	10 A			5 A		
Capacitance	< 1.5 pF			< 1.0 pF		
	<b>Type Cat No.</b>	<b>Std. Packing in Nos.</b>	<b>Wt Per unit in Grams</b>	<b>Type Cat No.</b>	<b>Std. Packing in Nos.</b>	<b>Wt Per unit in Grams</b>
	LA 75 V -	20	32	3LA 90 V -	20	32
	LA 90 V -	20	32	3LA 250 V -	20	32
	LA 240 V -	20	32	3LA 350 V -	20	32
	LA 600 V -	20	32	3LA 450 V -	20	32
	LA 1000 V -	20	32			
Terminal Block [Prefix DBL4UE to Type Cat.No ]						

End Plate		EPDBL4U	50	2.5	EPDBL4U	50	2.5
Spacer for terminal		DBL4USP	50		DBL4USP	50	
Mounting Rail		DIN 32G	50 M	750	DIN 32G	50 M	750
		DIN 35U	50 M	360	DIN 35U	50 M	360
		DIN 35-15D	50 M	700	DIN 35-15D	50 M	700
End Clamp		ES2N	50	7.4	ES2N	50	7.4
		ES3N	50	4.5	ES3N	50	4.5
Marking Tags (K Type)		KM/2	100	0.02	KM/2	100	0.02

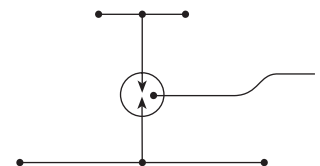
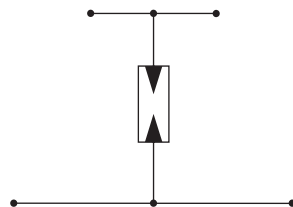

### DBL4UEMOV



### DBL4UESD



### DBL4UERC



### DBL4UERES

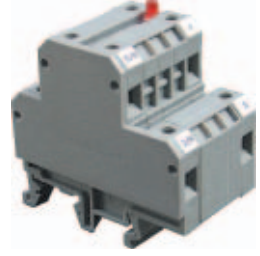

12 mm	12 mm	12 mm	32.5 mm
54 x 55.5 mm	54 x 55.5 mm	54 x 55.5 mm	54 x 55.5 mm
9 mm	9 mm	9 mm	9 mm
Polyamide 6.6	Polyamide 6.6	Polyamide 6.6	Polyamide 6.6
4 Screw Clamps	4 Screw Clamps	4 Screw Clamps	4 Screw Clamps & 1C Relay, 10 A
0.5 - 4 sq.mm / 22-10 AWG	0.5 - 4 sq.mm / 22-10 AWG	0.5 - 4 sq.mm / 22-10 AWG	0.5 - 4 sq.mm / 22-10 AWG
30 V, 60 V, 75 V, 130 V, 275 V, 460 V, 510 V, 625 V, 680 V	12 V to 48 V - / 12 V to 160 V ~	250 V ~ / 630 V -	12 V, 18 V, 24 V, 48 V D.C (Coil Voltage)
2 KA - 6.5 KA (8/20 $\mu$ s)	1.5 KW	20 A	
< 25 ns	1 ns (D.C) / 5 ns (A.C)		8 ms
10 A	10 A	10 A	5 A - 230 V ~ / 24 V - 10 A - 120 V ~ / 12 V -

Type Cat No.	Std. Packing in Nos.	Wt Per unit in Grams	Type Cat No.	Std. Packing in Nos.	Wt Per unit in Grams	Type Cat No.	Std. Packing in Nos.	Wt Per unit in Grams	Type Cat No.	Std. Packing in Nos.	Wt Per unit in Grams
MOV 30 V ~	20	35	SDUA15V	20	35	RC 0.1 $\mu$ f	10	60	RES12 V -	10	60
MOV 60 V ~	20	35	SDUA24V	20	35	RC 0.22 $\mu$ f	10	60	RES18 V -	10	60
MOV 75 V ~	20	35	SDUA48V	20	35				RES24 V -	10	60
MOV 130 V ~	20	35	SDUK15V	20	35				RES48 V -	10	60
MOV 275 V ~	20	35	SDUK24V	20	35						
MOV 460 V ~	20	35	SDUK48V	20	35						
MOV 510 V ~	20	35	SDB15V	20	35						
MOV 625 V ~	20	35	SDB24V	20	35						
MOV 680 V ~	20	35	SDB48V	20	35						
			SDB160V	20	35						
EPDBL4U	50	2.5	EPDBL4U	50	2.5	EPDBL4U	50	2.5	EPDBL4U	50	2.5
DBL4USP	50		DBL4USP	50		DBL4USP	50		DBL4USP	50	
DIN 32G	50 M	750	DIN 32G	50 M	750	DIN 32G	50 M	750	DIN 32G	50 M	750
DIN 35U	50 M	360	DIN 35U	50 M	360	DIN 35U	50 M	360	DIN 35U	50 M	360
DIN 35-15D	50 M	700	DIN 35-15D	50 M	700	DIN 35-15D	50 M	700	DIN 35-15D	50 M	700
ES2N	50	7.4	ES2N	50	7.4	ES2N	50	7.4	ES2N	50	7.4
ES3N	50	4.5	ES3N	50	4.5	ES3N	50	4.5	ES3N	50	4.5
KM/2	100	0.02	KM/2	100	0.02	KM/2	100	0.02	KM/2	100	0.02

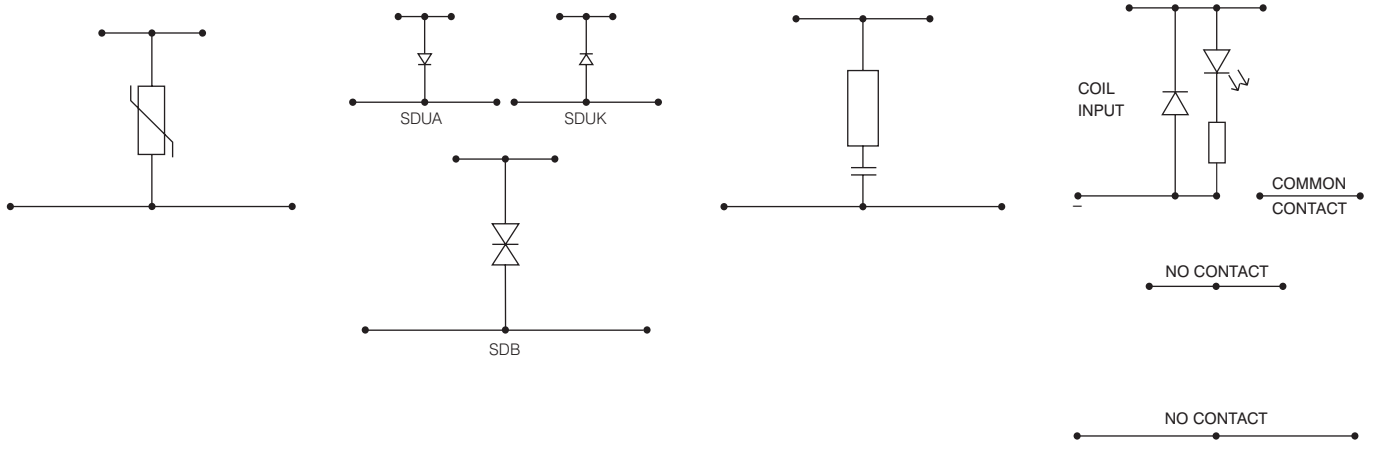

## Thermocouple Terminal Blocks

Thermocouple terminal blocks are offered for accurate measurement of temperature. The sensing part of terminal block has the same material (DIN 43713 & DIN 43714) as for compensating cables used in temperature measurement (upto 200° C) fulfilling the accuracy stated in DIN EN 60584.

The terminal blocks are marked for the respective thermocouple material used for the current bars, which enables easy identification for wiring.





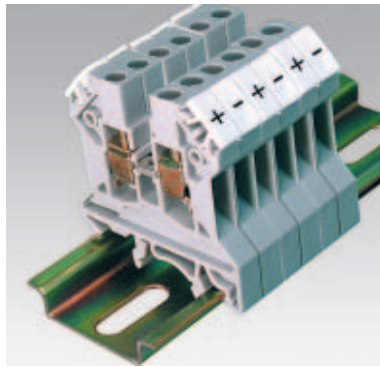

- 'K' type - Chromel (Ni/Cr) + Alumel (Ni/Al) -
- 'J' type - Iron (Fe) + Constantan (Cu/Ni) -
- 'T' type - Copper (Cu) + Constantan (Cu/Ni) -

Please refer for other types of thermocouple terminal blocks.



### TH2.5U



Terminal Pitch		10 mm		
Height x Width		45 x 43 mm		
Connection Possibility	Stranded Wire Solid Wire	0.5 to 2.5 sq.mm 0.5 to 4 sq.mm		
Stripping Length		9 mm		
Insulation Material		Polyamide 6.6		
Type of Connection		4 screw clamps connection		
Approvals		CSA Standard	IEC Standard	UL Standard
Rated Cross Section		24-14 AWG	0.5-2.5 sq.mm	24-14 AWG
Voltage Rating		300 V	750 V	300 V
Current Rating		10 A	10 A	10 A
Torque		7 lb-in	0.5 Nm	7 lb-in
		<b>Type Cat No.</b>	<b>Std. Packing in Nos.</b>	<b>Wt Per unit in Grams</b>
Terminal Block		TH2.5UK TH2.5UJ TH2.5UT	50 50 50	12 12 12
End Plate		EPSCRW2.5U/4U	50	1.7
Partition Plate		PPSCRW2.5U/4U	50	2.3
Separator Plate		SPSCRW2.5U/4U	100	0.1
Mounting Rail		DIN 32G DIN 35U DIN 35-15U	50 M 50 M 50 M	750 360 700
End Clamp		ES2N ES3N	50 50	7.4 4.5
Marking Tags		KM/5	100	0.07

## ACCESSORIES

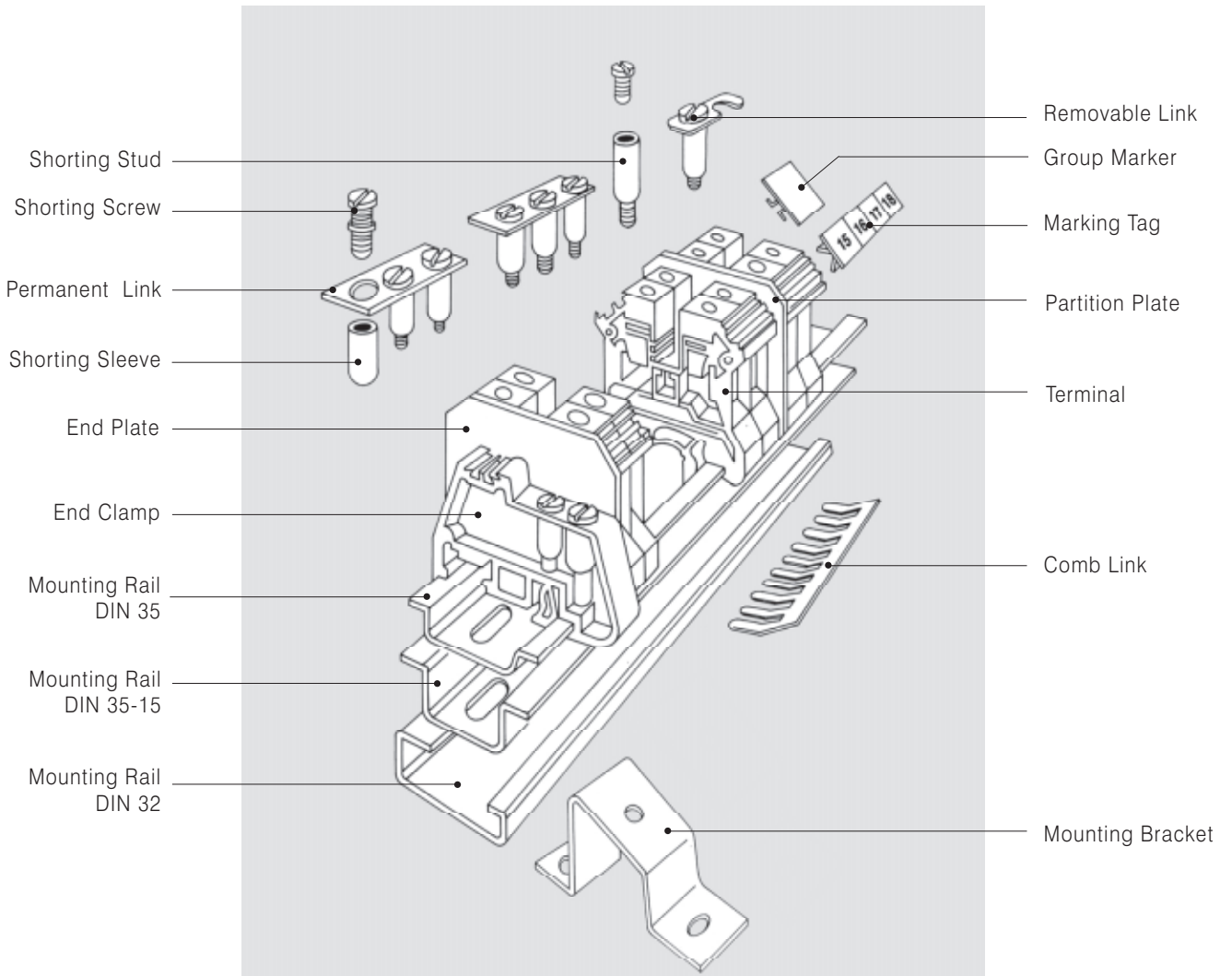



## End Clamps/Stops

The End Clamps keep the terminal block assembly securely in position. End Clamp should be fixed on both sides of terminal block assembly for rigidity and sturdiness.

The end clamps in Polyamide 6.6 have suitable recess to accommodate marking tag for group identification.

ES1S	ES2S	ES3S	ES1N
			
39.5 x 27 x 16 mm Suitable for DIN 35 Rail. (Steel)	39.5 x 27 x 16 mm Suitable for DIN 35-15 Rail. (Steel)	25 x 22.5 x 11.5 mm Suitable for DIN 32 Rail. (Steel)	20 x 28 x 8 mm Suitable for DIN 15 Rail.
ES2N	ES3N		
			
34 x 44 x 9 mm Suitable for DIN 32 / DIN 35 / DIN 35 -15 Rails.	45 x 32 x 8 mm Suitable for DIN 35 / DIN 35 -15 Rails.		

## Mounting Rails

Most of the terminal blocks are designed to mount on the rails that can be fixed easily on panel boards and equipment.

Three types of steel mounting rails; DIN 32, DIN 35/DIN 35-15 and DIN 15 complying to European standards EN 50035, EN 50022 and EN 50045 are offered. The rails are zinc plated and chromate passivated.

All mounting rails are available in standard 1 m and 2 m lengths. Choice of slotted/unslotted rails in DIN 32 and DIN 35 types is available.\*

Mounting rails made of steel in accordance with DIN VDE 0611 Part 3 are permissible as grounding bus bars (PE function), but do not have PEN function.

*\*Mounting rails cut to length with holes/slots as per customer requirements can be supplied.*

DIN 32 Rail	DIN 35 Rail
	
32 x 15 x 1.5 mm Suitable for all terminals except Micro Terminals, PCB Terminals, Modular Terminals and GN Terminals.	35 x 7.3 x 1.0 mm Suitable for all terminals except Micro Terminals, PCB Terminals, Modular Terminals and GN Terminals.
DIN 35 - 15 Rail	DIN 15 Rail
	
35 x 15 x 1.5 mm Suitable for all terminals except Micro Terminals, PCB Terminals, Modular Terminals and GN Terminals.	15 x 5 x 1.0 mm Suitable for Micro Terminals

## Mounting Brackets



Mounting brackets are used for installation of mounting rails at an angle to facilitate better access and for more clearance from surface of the panel. The mounting brackets are zinc plated and chromate passivated.

MTGBKT18	MTKGBASE18
	
Suitable for all Mounting Rails.	58 x 18 x 18 mm mounting base for panel mount terminals on DIN 35 rails. (Hole dia 4.3 - 4 Nos & 5.5 - 2 Nos)

## End Plates (Polyamide 6.6)

End Plates are used to cover the live parts of the last terminal block in the assembly.

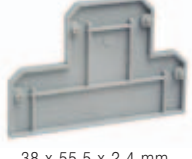
End plates must also be inserted when different size terminals are used in the assembled blocks for rigidity.

<p><b>EPSCRW2.5U/4U</b></p>  <p>30 x 39 x 2.6 mm Suitable for SCRW2.5U/4U</p>	<p><b>EPSCRW6U/10U</b></p>  <p>31 x 42.5 x 1.5 mm Suitable for SCRW6U/10U</p>	<p><b>EPSCRW25U</b></p>  <p>40 x 48 x 2 mm Suitable for SCRW25U</p>	<p><b>EPSCRW35U</b></p>  <p>43 x 50 x 1.5 mm Suitable for SCRW35U</p>	
<p><b>EPM4</b></p>  <p>22.5 x 27 x 1.5 mm Suitable for M4/4S/4SU</p>	<p><b>EPP4</b></p>  <p>27 x 27 x 7 Suitable for P4</p>	<p><b>EPDBL4U</b></p>  <p>38 x 55.5 x 2.4 mm Suitable for DBL4U/4U(L/S)/4UO &amp; all electronic terminals</p>	<p><b>EPDBLOFF4U</b></p>  <p>49 x 68 x 5.5 mm Suitable for DBLOFF4U (Front Side)</p>	<p><b>EPDBLOFF4UA</b></p>  <p>24 x 68 x 3 mm Suitable for DBLOFF4U (Back Side)</p>
<p><b>EPF4U</b></p>  <p>23.5 x 55.5 x 1.6 mm Suitable for F4U/DISCTL4U/F4U(L)</p>	<p><b>EPFDBL4U</b></p>  <p>49 x 87.6 x 3 mm Suitable for FDBL4U/4UE/4U(LR)</p>	<p><b>EPDISCT6U</b></p>  <p>41 x 63 x 2.95 mm Suitable for DISCT6U</p>	<p><b>EPKN4U</b></p>  <p>30.5 x 46.5 x 2.5 mm Suitable for KN4U</p>	<p><b>EPTAB4U</b></p>  <p>34.5 x 47 x 2.5 mm Suitable for TAB4U</p>
<p><b>EPPCB</b></p>  <p>19 x 14.5 x 2.5 mm Suitable for PCB5</p>	<p><b>EPPCB</b></p>  <p>18 x 19 x 2.5 mm Suitable for PCB5</p>	<p><b>EPSCRW4U 1-2</b></p>  <p>35.5 x 46.5 x 2.5 mm Suitable for SCRW4U1-2</p>	<p><b>EPSCRW4U 2-2</b></p>  <p>40.5 x 65 x 2.5 mm Suitable for SCRW4U 2-2</p>	<p><b>EPFA4U</b></p>  <p>32 x 72 x 1.5 mm Suitable for FA4U</p>
<p><b>EPTL2.5U</b></p>  <p>55.8 x 84.5 x 2 mm Suitable for TL2.5U</p>	<p><b>EPCAGE2.5</b></p>  <p>23 x 58 x 1.5 mm Suitable for CAGE2.5</p>	<p><b>EPCAGE4</b></p>  <p>28 x 65 x 1.5 mm Suitable for CAGE4</p>	<p><b>EPCAGE6</b></p>  <p>32.5 x 72 x 2 mm Suitable for CAGE6</p>	<p><b>EPCAGEP2.5</b></p>  <p>35 x 27.5 x 5 mm Suitable for CAGEP2.5</p>
<p><b>EPCAGE2.5 1-2</b></p>  <p>25 x 74 x 1.5 mm Suitable for CAGE2.5 1-2</p>	<p><b>EPCAGE4 1-2</b></p>  <p>28.4 x 84.6 x 1.5 mm Suitable for CAGE4 1-2</p>			

Type/ Cat. No.	Dimensions(HxWxT)mm	Suitable for
EPCAGE2.5	58×23×1.4	CAGE2.5
EPCAGE2.5 1-2	74.1×25.2×1.6	CAGE2.5 1-2
EPCAGE2.5 2-2	89.7×25.1×1.5	CAGE2.5 2-2
EPCAGE4	64.9×28×1.5	CAGE4
EPCAGE4 1-2	84.5×28.5×1.5	CAGE4 1-2
EPCAGE4 2-2	104.7×28.6×1.6	CAGE4 2-2
EPCAGE6	71.8×31.5×1.9	CAGE6
EPCAGE6 1-2	93.5×36.5×1.9	CAGE6 1-2
EPCAGE6 2-2	115.6×31.5×1.9	CAGE6 2-2
EPSCRW4U 1-2	44.6×35.8×2.5	SCRW4U 1-2
EPSCRW4U 2-2	65×40.8×2.5	SCRW4U 2-2
EPDBL 4U	54.8×37.7×2.3	DBL4U/DBL4U(IS)/DBL4UCLIP/DBL4UED1/D2, DBL4UED3, DBL4UEDD1/DD2, DBL4UEDD3/DD4, DBL4UED4, DBL4UEDD5, DBL4UELD3, DBL4UELD4, DBL4UELD5, DBL4UEN1, DBL4UELD1.LD2, DBL4UEL1/L2, DBL4UO, DBL4UELA, DBL4UE3LA, DBL4UEMOV, DBL4UESD, DBL4UERC, DBL4UERES
EPFDBL4U	88×66×1.5*	FDBL4U/FDBL4UE/FDBL4UE(LR)/DBL4DISCTL4U
EPDBLOFF 4U	68×49×2.5	DBLOFF4U
EPDBLOFF4UA	68×24×3	DBLOFF4U
EPDISCT6U	63.1×41.1×2.9	DISCT6U/DISCT6US
EPF4U	56×23.4×1.6	F4U/F4U(L)/DISCTL4U
EPF6U	42.5×35.5×1.5	F6U/DISCTL6U
EPFA4U	32×71.9×1.6	FA4U
EPKN4U	46.6×30.2×2.5	KN4U
EPM4	27×22.4×1.6	M4/M4S
EPP4	27×27×7	P4
EPPCB	15×19×1.5*	PCBM5H, PCBM5A, PCBM5V, PCB5, PCB7.5,
EPSCRW2.5U/4U	34.2×29.7×2.6	SCRW2.5U/SCRW4U/SCRW2.5UCR/SCRW4UCR/SCRW4UTAB/SCRW4UCLIP,TH2.5U
EPSCRW25U	48×39.8×2	SCRW25U/SCRW25UCR
EPSCRW35U	50.4×42.8×1.5	SCRW35U/SCRW35UCR
EPSCRW6U/10U	42.5×31×1.5	SCRW6U/SCRW10U/SCRW6UCR
EPSCRW16U	42.5×33.8×1	SCRW16U/SCRW 16UCR
EPTAB4U	47×34.5×2.5	TAB4U
EPTL2.5U	55.5×83.8×1.5	TL2.5U
EPTL2.5UH	55.5×60.5×1.5	TL2.5UH/TL2.5UHL
EPCAGEP2.5	35.1×27.4×5	CAGEP2.5/CAGEP2.5 2-2

\* Approx.

## Polyamide 6.6 Series Partition Plates

Apart from identifying and segregating terminal block groups, partition plates can be used to electrically isolate adjacent cross connection sets. It also helps to maintain the required creepage and clearances.

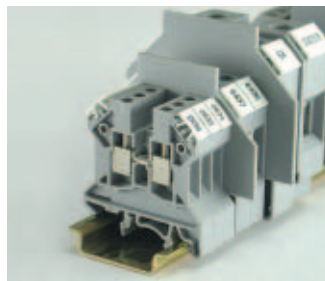

**PPSCRW2.5U/4U**



37 x 44 x 1.6 mm  
Suitable for SCRW2.5U/4U

**PPSCRW6U/10U**



37.5 x 56.5 x 1.5 mm  
Suitable for SCRW6U/10U

**PPSCRW25U**



46.5 x 16.5 x 1.5 mm  
Suitable for SCRW25U

**PPSCRW35U**



50 x 61.5 x 1.5 mm  
Suitable for SCRW35U

**PPM4**



32.5 x 37 x 1.6 mm  
Suitable for M4/4S/4SU

## Polyamide 6.6 Series Partition Plates

### PPF4U



42.5 x 62 x 1.5 mm  
Suitable for F4U/  
DISCTL4U/F4U(L)

### SPDBL4U



15 x 10 x 1.6 mm  
Suitable for DBL4U

### SPACER8

Spacer



43 x 29 x 8 mm  
Suitable for all rail  
mounted terminals

Type/ Cat. No.	Dimensions(HxWxT)mm	Suitable for
PPCAGE2.5	58×23×1.4	CAGE2.5
PPCAGE2.5 1-2	74.1×30.2×1.6	CAGE2.5 1-2
PPCAGE2.5 2-2	89.7×25.1×1.5	CAGE2.5 2-2
PPCAGE4	64.9×28×1.5	CAGE4
PPCAGE4 1-2	84.5×33.5×1.5	CAGE4 1-2
PPCAGE4 2-2	104.7×33.6×1.6	CAGE4 2-2
PPCAGE6	71.8×36.5×1.5	CAGE6
PPCAGE6 1-2	93.5×31.5×1.5	CAGE6 1-2
PPCAGE6 2-2	115.6×36.5×1.9	CAGE6 2-2
PPF4U	61.9×42.6×1.6	F4U
PPFA4U	50×81.9×1.6	FA4U
PPF6U	57.5×56.2×1.3	F6U
PPM4	36.6×32.2×1.6	M4/M4S
PPSCRW2.5U/4U	43.9×36.7×1.5	SCRW2.5U/SCRW4U/SCRW2.5UCR/SCRW4UCR/TH2.5U/SCRW4UTAB
PPSCRW25U	61.9×46.8×1.5	SCRW25U/SCRW25UCR
PPSCRW35U	64.5×5×1.5	SCRW35U/SCRW35UCR
PPSCRW6U/10U	56.2×37.6×1.3	SCRW6U/SCRW10U/SCRW6UCR/SCRW10UCR

## Separator Plates

Separator plate can be used to electrically isolate adjacent cross connection sets. It also maintains the required creepage and clearance values. The Separator plate is fitted in the specially designed groove of the terminal block, without occupying additional space.



Type/ Cat. No.	Dimensions(HxWxT)mm	Suitable for
SPDBL4U	15.5×16.2×1.6	DBL4U
SPP4	14.5×12×1.5	P4
SPSCRW16U	50×61.5×1.5	SCRW16U
SPSCRW2.5U/4U	17.5×17.4×1.4	SCRW2.5U/SCRW4U
SPSCRW6U/10U	Please – call for details	SCRW6U/SCRW10U

## Cross Connecting Accessories

Various functional requirements can be achieved with cross connecting systems. Different type of cross connecting accessories offered include variety of temporary shorting links, permanent shorting links, shorting studs, shorting sleeves, multipole comb links and pre assembled shorting links.

### Permanent Shorting Links



Permanent shorting links in tin plated copper / brass are used for permanent cross connection of terminal blocks of the same potential. These links should be electrically connected to the terminal blocks with short Shorting sleeves / studs.

Permanent shorting links are available in 2 pole, 3 pole, 4 pole and ten pole lengths. When permanent shorting links are installed, terminal blocks are safe from accidental contact because the links rest below the top surface of terminal block.

### Removable Shorting Links



Removable shorting links in tin plated copper / brass are used for switchable cross connection. These links should be electrically connected to the adjacent terminal block of the same potential with of Long Shorting sleeves / studs. It is recommended to use partition plate for isolation of such cross connected terminals.

### Comb Links



Comb type links are used for cross connection wherever terminals in assemblies cannot be cross connected with the aid of conventional shorting links, Sleeves / Studs.

Multi pole comb type link provides choice of consecutive shorting or alternate shorting. These links are insulated which makes them shock-proof. Comb links without insulation are also available.

### Shorting Sleeve



Shorting Sleeve in Tin / Nickel plated brass along with steel fixing screw are used for quick cross connection of terminal blocks in conjunction with shorting links (Permanent / Removable).

Short Shorting sleeves (For permanent cross connection) and Long shorting sleeve (For temporary cross connection) may be selected according to the functional requirement.

### Shorting Stud



Shorting Stud screws in Tin / Nickel plated brass along with steel fixing screw are used for cross connection of terminal blocks in conjunction with shorting links (Permanent / Removable).

Short Shorting stud (For permanent cross connection) and Long shorting stud (For temporary cross connection) may be selected according to the functional requirement.

### Pre Assembled Shorting Links



Pre assembled shorting links with captive sleeves and screws are recommended for quick cross connections.

Two pole, three pole, four pole and ten pole assemblies of links and sleeves have the following advantages :

- Cross connection task is simplified.
- Eliminates possibility of losing sleeves or screws while cross connecting.
- Saves considerable time in cross connecting.

### Insulated Push-In Type Shorting Links



Insulated Push-In Type Shorting Links are specially designed for use in 'Screw less' Spring Clamp Terminals. The links besides providing shock protection, simplify the task of cross connection.

Choice of adjacent and alternate Shorting Links is available.

The link has to be inserted into the slot provided in the current carrying part of the terminal to bridge with a adjacent/alternate terminals.

Shorting Sleeve For	L	L1	D	L2	L3	M
SCRW2.5U	8	14.5	4.4	14	20	M2.5
SCRW4U	8	14.5	4.4	14	20	M2.5
SCRW6U/SCRW10U	12.5	18.5	5.5	19	25	M3
CTS25U/CTS35U	14.5	21.5	7	23	31	M4
SCRW4U 1-2/SCRW4U 2-2	8	14.5	4.4	14	20	M2.5
M4/DBL4U/DBLOFF4U	5	9.5	4.4	10	15	M2.5
P4	8	14.5	4.4	14	20	M2.5
TAB4U	5	-	4.4	10	-	M2.5

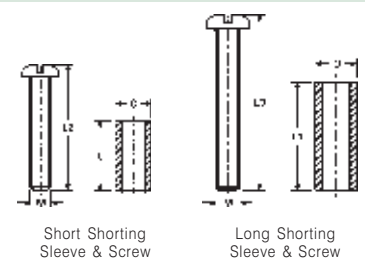

Shorting Link For	C				ØD
	2 Way	3 Way	4 Way	10 Way	
SCRW2.5U	5	5	5	5	2.7
SCRW4U	6	6	6	6	2.7
SCRW6U	8	8	8	8	3.3
SCRW10U	10	10	10	10	3.3
SCRW25U	12	12	12	12	4.2
SCRW35U	15	15	15	15	4.2
SCRW4U 1-2/SCRW4U 2-2/P4	6	6	6	6	2.7
M4/DBL4U/DBLOFF4U	6	6	6	6	2.7
FDBL4U	8	8	8	8	2.7

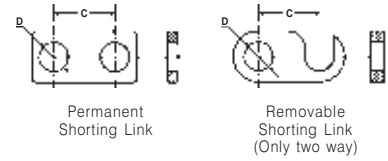

Comb Links For	P	W
SCRW4UN	6	17.5
SCRW4U 1-2/SCRW4U 2-2	6	17.5
M4 Series	6	17.5
P4	6	17.5
DBL4U Series	6	17.5
DBLOFF4U	6	17.5
F4U/FDBL4U	8	10.4
DISCT6U	8	21.5
KN4U	6	17.5
FA4U	9	21.5

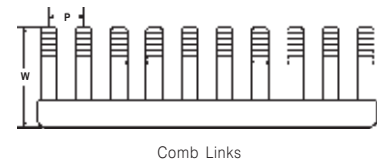

Comb Links

## Protective Covers and Holding Plates

For protection against dust and shock, transparent protective cover can be installed above the terminal block assembly with side holding plates. The side holding plates can be fitted on to DIN 32 as well as DIN 35 rails. These plates should be backed by standard end clamp.



For all rail mounting terminals except busbar type terminals

## Markers

Identification of individual electrical components in the switchgear is one of the major pre-requisites for purposeful and safe work. Systematic marking of individual terminal block facilitate system identification and quick maintenance.

All terminals are provided with suitable recesses for marking tags. Most of the terminal blocks are designed to accommodate two marking tags.

Markers are offered with horizontal or vertical imprints. Blank marking tags are also available.

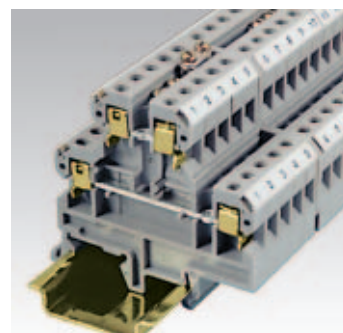

**'K' Type** Polyamide marking tags in strips facilitate quick and easy fixing on assembled terminal blocks. The strip comprising of 5 or 10 markers can be fixed on assembled terminals in one stroke. The strip can be detached easily at any point. Apart from good aesthetic looks, 'K' type markers have large surface area and better visibility.

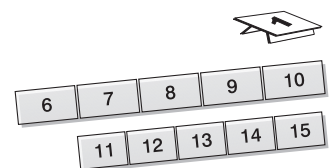

**Insert Type** PVC marking tags are to be detached into single tags and inserted in the terminal block recesses with a screw driver.

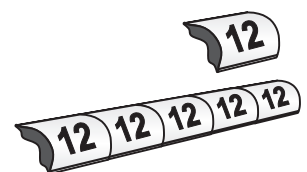

**Group Marker** These are in Polyamide 6.6, with large blank surface area and can be used for group identification. These markers can be fixed on the Polyamide 6.6 End Clamp or on the terminal block.

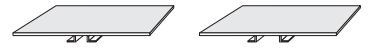

**Pre-Printed markers can be supplied in horizontal or vertical imprints in the following types:**

- Horizontal Print 

1	2	3	4	5	6	7	8	9	10
---	---	---	---	---	---	---	---	---	----
- Vertical Print 

1	2	3	4	5	6	7	8	9	10
---	---	---	---	---	---	---	---	---	----

Marker : KM/ Max. Marking Digits ↓	2	4	5	6	7.5	8	9	10	12	15
Horizontal	3	3	3	4	4	4	4	4	4	5
Vertical	2	3	5	5	3	5	4	5	5	5

**Pre Printed markers can be supplied in Horizontal or Vertical imprints in the following types:**

- **Individual Numbers:**  
Strips of same numerals 

1	1	1	1	1	1	1	1	1	1	1
---	---	---	---	---	---	---	---	---	---	---
- **Serial Numbers:**  
Strips of sequential numerals 

1	2	3	4	5	6	7	8	9	10
---	---	---	---	---	---	---	---	---	----
- **Individual Alphabets:**  
Strips of same alphabets 

A	A	A	A	A	A	A	A	A	A	A
---	---	---	---	---	---	---	---	---	---	---
- **Special Character:**  
Strips of same special characters 

24V~	24V~	24V~	24V~	24V~	24V~	24V~	24V~	24V~	24V~	24V~
------	------	------	------	------	------	------	------	------	------	------
- **Alpha Numerals:**  
Strips of alpha numerals 

A1	A2	A3	A4	A5	A6	A7	A8	A9	A10
----	----	----	----	----	----	----	----	----	-----

Marking tags can be supplied as **Blank Strips**. The user can print or write manually, the desired characters.

### Ordering Information of Markers

The details regarding various types of markers along with cross reference of terminal is given below.

Cat No.	Description	No. of Marking tags per packet	No. of Marker Strips per packet	No. of Marking tags per strip
KM/2	'K' type marker suitable for M4 , DBL4U , P4, F4U, FDBL4U	100	10	10
KM/4	'K' type marker suitable for PCBM & PCB5	100	10	10
KM/5	'K' type marker suitable for SCRW2.5U, GN4/16/35.	100	10	10
KM/6	'K' type marker suitable for SCRW4U/4UT, M4, DBL4U, G4U, DISBL4, KN4U, TAB4U	100	10	10
KM/7.5	'K' type marker suitable for PCB7.5	100	10	10
KM/8	'K' type marker suitable for SCRW6U, DISBL6 , F4U & FDBL4U.	100	10	10
KM/10	'K' type marker suitable for SCRW10U, DISBL10, G10U	100	10	10
KM/12	'K' type marker suitable for SCRW25U	100	20	5
KM/15	'K' type marker suitable for SCRW35U	100	20	5
KM/50	'K' type marker suitable for SCRW50U, SCRW95U	100	20	5
KM/G1	Group Marker suitable for ES2N or all the Terminals except M4 , DBL4U & P4	100	-	-
KM/G2	Group Marker suitable for ES1N or M4 , DBL4U, P4, SCRW50U, SCRW95U	100	-	-

- Unless otherwise specified, the pre printed marking tags shall be supplied with horizontal imprint.
- Suffix 'V' may be added to the catalogue number for marking tags with vertical imprint. For example KM/5(V), represents the marker KM/5 with vertical imprint.

## Marker Plotter

Marker Plotter, Vario Scriber VS 200 ensures quick, durable and clear printing for identifying and marking on the international 'K' type markers.

The plotter is versatile and is used to print on 'K' type marker strips placed on a 'workpiece holder'. The workpiece holder is changeable in a matter of seconds for printing on the different marker sizes. The printing process is easy with the menu driven software programme.

The plotter can be used any time, at any place since it is easily transported in its special carry case. The battery-operated, stand alone, Marker Plotter, Vario Scriber VS 200 can be operative at any place where the user needs it. The spacious carry case provides ample room for the extensive accessories like pen, workpiece, cleaning fluid etc.

Marker Plotter, Vario Scriber VS 200 is strongly recommended to Panel Board Manufacturers and Distributors for printing markers at site. Only blank 'K' type markers need to be stocked for promptly servicing the variety of marker requirements for identification in the wiring of terminal blocks.

## VARIO SCRIBER VS 200

With power supply, connecting cable, workpiece holder, print software for text transfer from PC to VS 200, a carry case and instruction manual.

Choice of plotter pens and ink-cartridges is available.



## Terminal Blocks

Wide range of terminals are offered to suit modern wiring techniques for performance and reliability in addition to safety, flexibility, efficiency, high density wiring, economy, ease of design and maintenance. The terminals offer the following functions, and more.

- Feed-Through
- Disconnect and Test
- Multilevel
- Ground/Earth
- Fuse
- Distribution
- Integral Electronics

Snap on mounting on the DIN rails saves time and space, improves design and layout and offers compact centralized connection area for quick and efficient external and/or internal wiring.

### TERMINAL DETAILS

#### ■ Screw Clamp Connection

- Connection can be made by simply stripping the wire of its insulation to the recommended length, and then tightening the clamp screw either without any additional preparation, or after protecting the wire with a ferrule. The clamping screw compresses the current carrying bar, which in turn acts on the wire.
- Screws are extremely important for the quality of the connection. Cold forged rolled threaded steel screws with good galvanic surface protection, zinc plated and chromate passivated are used for the terminals.
- Clamps, which transmit the force applied through the screw to the actual contact area between the wire and the current-carrying bar, are made of hardened steel, zinc plated and bichromated, in order to achieve the required contact pressure over the conductor and offer excellent resistance to corrosion.

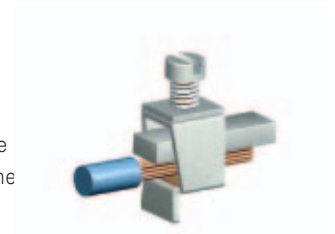



## ■ Spring Clamp Connection

- In spring clamp terminals the clamping action is taken over by a high quality, stainless steel pre-stressed spring.
- The pre-stressed spring is opened using a screw driver so that the wire can be inserted into the clamping space through an opening now created. Once the screw driver is removed, the conductor is pressed hard against the current bar with full spring force ensuring an effective connection.
- As the wire holding spring plays critical role in clamping, it is specially designed and tooled. It is stainless steel with special long life shape retaining properties in-built for reliability of wire termination.



- Current-carrying bars are made from electrolytic copper or alpha brass, electroplated and coated for surface protection while ensuring very low contact resistance.
- Clamping yokes and screws are zinc plated and passivated by a golden yellow chromate layer, considerably increasing corrosion resistance.
- The metal parts of terminals are housed in precision molded, almost unbreakable, self extinguishing flame retardant polyamide 6.6 material rated UL94-V2, for high dielectric strength, electrical insulation and temperature resistance (max. operating temperature 100°C). Terminals in UL94VO grade polyamide 6.6 can be offered on request.

Additional colours for the terminal block shell or housing are offered as under:

Colour	Suffix to Cat. Ref.	Suffix to Cat. Ref.	Colour
Red	RD	BG	Beige
Blue	BL	BR	Brown
Black	BK	KH	Khaki
Orange	OR	GY	Grey
Green	GN	PK	Pink
Yellow	YL		
White	WH		

Please add the colour suffix to Cat. Ref. while ordering.

Typical properties of insulation material of the shell or housing are as under:

Property	Unit	Thermoset High Grade Melamine	Engineering Thermoplastic Polyamide 6.6
Specific Gravity	--	1.5	1.2 - 1.15
Upper Limit Temperature	°C	130	100
Lower Limit Temperature	°C	- 55	- 50
Volume Resistivity	$\Omega$ cm	$10^{11}$	$10^{12}$
Surface Resistivity	$\Omega$	$10^{10}$	$10^{10}$
Dielectric Strength	KV/cm	100	400
Tropical Resistance	--	Good	Good
Flammability ( UL 94 )	Grade	V0	V2 #
Flexibility	--	--	Excellent

## WIRE TERMINATION

The terminals are suitable for connection of either solid or stranded copper wires as per the gauge range specified.

It is recommended to connect only one wire of the rated cross section in a clamp. Connecting more than one wire per clamp may result in poor contact and overheating.

Stranded wires can be connected without any special preparation, but particular care should be taken when stripping the wires in order not to cut any of the strands. A good quality stripping tool, which provides fast stripping of most insulated wires without damage to the conductors is strongly recommended. With flexible cables of fine strands, the strands may be twisted between finger and thumb. Twisting should never be done with pliers. In order to improve the quality of the connection, and for all those cases where frequent removal

(i.e. for testing) and reinsertion of the wire is expected, it is recommended using a ferrule – insulated or uninsulated – or a flat crimp terminal.

## ASSEMBLY OF TERMINAL BLOCKS

All the terminal blocks are designed to be installed on standard DIN rails, either symmetrical (DIN35, DIN35-15, DIN15) or asymmetrical (DIN32). When mounting terminal blocks, the following accessories are always necessary:

- End Plate(s), at least one, at the open end of the last terminal block.
- End stops, at each end of the terminal block assembly.

Other accessories include:

- Partition Plates, inserted between blocks, these help preventing accidental contact between wires, etc..
- Angled steel brackets, to lift the DIN rail above the bottom of the panel;
- Jumper bars 2, 3 and 4 poles, assembled with appropriate screw and spacers;
- Pre-assembled jumper bars, 10 poles;
- Jumper comb links, 2-pole to 10-pole, to interconnect adjacent terminal blocks;
- Moving jumpers, assembled with appropriate screw and spacers. These provide economical and safe temporary shorting between adjacent blocks;
- Marker strips, either blank (to be marked) or pre-marked.

To determine the length of the mounting rail required, calculate the sum of:

- Thickness of one terminal (including tolerance if applicable) times number of terminals
- Thickness of one end plate, and of separator plates, if used
- Thickness of two end stops
- Plus minimum 25 mm. (~1") on either side, for easy mounting on the panel.

Extra terminals can be added to an existing assembly at any time. Individual terminals can be replaced easily, without removing adjacent blocks.

To remove a terminal block from the DIN rail, simply insert the tip of a screwdriver in the slot provided at the outside edge of the flexible foot of every terminal block.

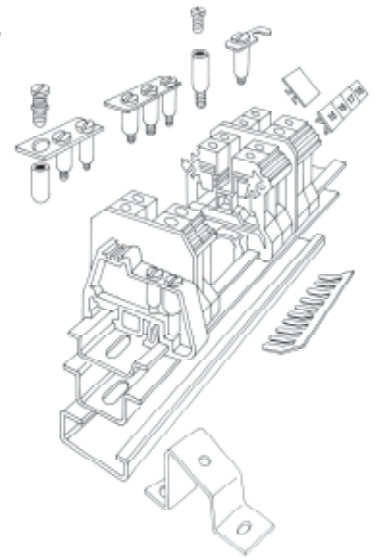

## Accessories

### Insulated Pre Assembled Shorting Links



Insulated Pre Assembled Shorting Links are ideal choice for quick permanent cross connections of the terminals. Available in 2/3/4/10/100 pole assembly, the Pre Assembled Shorting Links have following advantages :

- Eliminate possibility of losing sleeves/screws while cross

connecting with captive screws.

- Insulated captive screws make the assembly shock proof and finger safe.
- Saves considerable time for cross connections.
- Simplify the task of cross connections with simple application.

### End Clamps/Stops



Cat No. : ES4N

Dimensions (H×W×T)mm : 14.5x25.4x11.8

Suitable for : DIN 32 Rails

## Group Marker Holders

Group Marker Holders are offered in two versions:

- GRPM1 to GRPM5, to be mounted on End Clamps.
- GRPM6 and GRPM7 for direct mounting on DIN channels.

GRPM1 to GRPM5 Group Markers can be inserted in the groove on the end clamp and are intended for group identification of terminals used in the assembly.

GRPM6 and GRPM7 are intended for identification, independent of actual terminals used in the assembly. A sticker/paper can be inserted in the slot, which will be covered by a transparent acrylic sheet.

Assembly	GRPM1	GRPM2	GRPM3	GRPM4
				
Mountable on	ES1N	ES3N	ES2N	ES3N
Assembly	GRPM5	GRPM6	GRPM7	
				
Mountable on	ES2N	All mounting rails	All mounting rails	

Product improvement is a continuous process, hence data given in this catalogue is subject to change without intimation. Please call for details of product certification and current status. All dimensions in mm.



- Nylon, feed-through, screw clamp and spring clamp Terminal Blocks for DIN rail and panel mounting.
- Wide range covering multiple connections, grounding, distribution, safety fuse link, disconnect, double/triple levels, PCB and electronic Terminal Blocks.
- Secure grip of screw clamps with special serrations over solid or stranded wires.



- Rolled screws provide calibrated tightening torque for securing wires in the clamp.
- Special spring steel clamps ensure a tight, yet gentle "non-fraying" grip over solid or stranded wires.
- Finely crafted current bar ensures "safe bridge" for the rated current.

- Series 'U' Terminals, with unique clamping foot suitable for DIN 35, DIN 35-15 and DIN 32, offer flexibility to permit low stock levels to Distributors, Panel Builders and Users.
- Carry UL and CSA marks for North America and VDE\* and CE mark for Europe.



**salzer**

Salzer Electronics Limited, Unit 2,

Chinnamaddampalayam, Bilichi post, Coimbatore - 641 019, India.

