



The Crimping people... since 1960

billets ELEKTRO WERKE LTD.



Cable Lugs, Connectors & Crimping Tools

An ISO 9001 / 2008 Company



The Crimping people... since 1960



(1929-2006)

In loving memory of Shri. Govindbhai S. Patel
The Pioneer of Cable Jointing Technology in India
The Founder of Dowell's and
3D brand Cable Lugs and Crimping Tools.



The Crimping people... since 1960

Certifications / Awards

ELECTRICAL RESEARCH AND DEVELOPMENT ASSOCIATION		ELECTRICAL RESEARCH AND DEVELOPMENT ASSOCIATION	
DATE: 23/03/2007		SHEET 2 OF 2	
No.	Test Detail	Requirement	Obtained value
1.1	Visual Examination Sample 01 Sample 02 Sample 03	The sample shall be examined for fracture from flexure, cracks, cracks & other defects harmful for the joint. The sample shall be examined for fracture from flexure, cracks & other defects harmful for the joint. The sample shall be examined for fracture from flexure, cracks & other defects harmful for the joint.	Conforms Conforms Conforms
1.2	Dimensional check up IS: 8309 Sample 01 Sample 02 Sample 03	As per given Table 1 of IS: 8309-1995	Conforms to drawing Conforms to drawing Conforms to drawing
1.3	Flexing test IS: 8309 Sample 01 Sample 02 Sample 03	Apply gradually increasing load until the normal surface are in contact one at least half of the internal width of terminal end pins. There shall be no crack observed.	No crack was observed No crack was observed No crack was observed
1.4	Chemical composition test IS: 8309 Table 1 of IS: 8309 Sample 01 Sample 02 Sample 03	As per given Table 1 of IS: 8309-1995	Conforms Conforms Conforms

Electrical Research & Development Association

भारतीय मानक ब्यूरो		BUREAU OF INDIAN STANDARDS	
REGISTERED A/D		Date: 31 Jan 2007	
Subject: Grant of BIS Certification Marks Licence No. CML-7701873 as per IS 8309: 1995			
Product: Compression type tubular terminal ends for aluminium conductors of insulated cables			
Type/Class/Grade/Variety covered under license: Compression type tubular terminal ends for aluminium conductors of insulated cables of designation CA-95 and CA-400			
2. The license is being granted with the explicit condition that you will mark entire/substantial production which conforms to the Indian Standards referred above.			
3. The number assigned to this license is CML-7701873 which has been made operative from 29/01/2007 and is valid upto 28/01/2008. The license number should invariably be referred to in your future correspondence.			

IS - 8309



Test Certificate for Cu. light duty terminals 120mm², 240mm² lugs

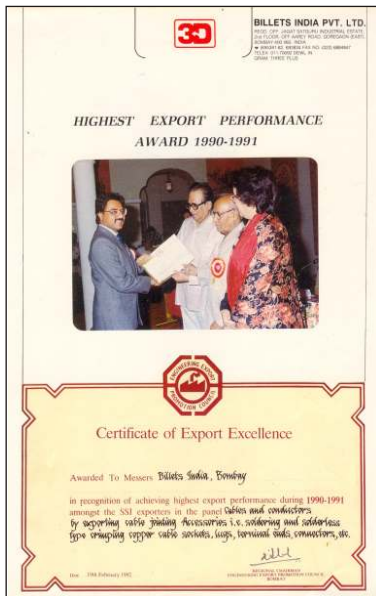

Highest Exporter Performance Award 1990 - 1991



All India Highest Export Performance Award 1991 - 92

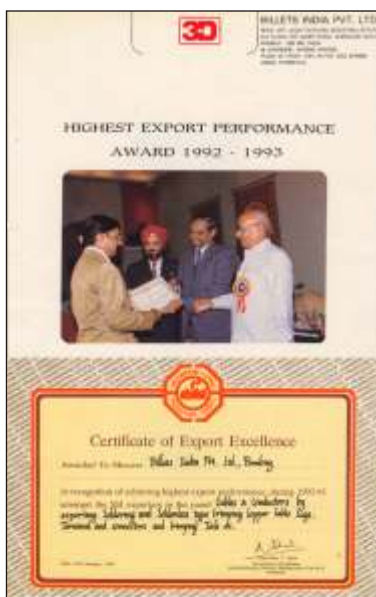

Highest Exporter Performance Award 1992 - 1993



Regional Trophy for Highest Exporter 2002 - 03



The Crimping people... since 1960

Product Index

Product Category	Page No.
Tubular Cable Lugs	
<ul style="list-style-type: none"> Standard type, with inspection hole for copper conductors Extra long type, without inspection hole Economy series, without inspection hole for aluminum conductors Standard type, without inspection hole for copper conductors Extra wide palm, with inspection hole Stand New type without inspection hole for copper conductors ICF / CLW / DLW 	1 - 3 4 5 6 - 8 9 10-13
Connectors	
<ul style="list-style-type: none"> Standard type, with cable stopper 	14
Butt Connectors	
<ul style="list-style-type: none"> For parallel connection, without cable stopper For copper conductors, with & non-insulating sleeve 	15 15
Tubular Cable Lugs Compression Type	
<ul style="list-style-type: none"> Aluminum terminal ends for crimping to XLPE conductors Aluminum tubular terminal ends for crimping to aluminum conductors Aluminum tubular in-line connectors for crimping to aluminum conductors 	16 17 18
3D-112 Corrosion Inhibiting Compound	18
End Sleeves	
<ul style="list-style-type: none"> Dimension DIN 46228, Part 4 Twin - Cable end sleeve, standard type, with insulating sleeve Dimension DIN 46228, Part 1 	19 20 20-21
Sheet Metal Lugs, Ring Type	
<ul style="list-style-type: none"> Standard type, brazed seam Standard type, with insulating sleeve Double grip, with insulating sleeve 	22 - 25 26 - 27 28 - 29
Sheet Metal Lugs, Fork Type	
<ul style="list-style-type: none"> Standard type, brazed seam Standard type, with insulating sleeve Double grip, with insulating sleeve / Sheet metal lugs Rectangular pin Type 	30 31 32
Sheet Metal Lugs, Round Pin Type	
<ul style="list-style-type: none"> Without sleeve, brazed seam With insulating sleeve Double grip, with insulating sleeve 	33 33 34
Sheet Metal Lugs, Flat Pin Type	
<ul style="list-style-type: none"> Standard type sleeve, brazed seam With insulating sleeve Double grip, with insulating sleeve Brass copper connectors Male / Female / Bus Bar 	35 35 35 36-37
Tools	
<ul style="list-style-type: none"> Hand crimping tool "3D - 17" Hand crimping tool "3D - 2" Hand crimping tool "3D - 41" Hand crimping tool "3D - 48" Hand crimping tool "3D - 52" Hand crimping tool "3D - 53" Hand crimping tool "3D - 95" Dieless tool "3D - 95B" Hand crimping tool "3D - 7" Cable cutter "3D - 31" Heavy duty crimping tool "3D - 150" Heavy duty crimping tool "3D - 100" Cable cutter "3D - 30" Hand crimping tool "3D - 88" 	38 38 39 39 40 40 41 41 42 42 43 44 45 45
Quality policy & approval vendors	46

Note: "All dimensions indicated in the catalogue are nominal dimensions, product produced may vary in size within the stipulated tolerances."



The Crimping people... since 1960

The History

The Company was first established in 1950 by Mr. G. S Patel and started producing Cycle Rickshaws. Mr. Patel with his vast engineering background, subsequently diversified the company into manufacturing:

Stardelta Starters	in 1954	Time Switches	in 1961
		Centrifugal Switches for Motors	
		Components of KWH Meters	
		Push-Button Switches for fans	
Switchgears	in 1958	introduced for the first time in India by us.	
		Terminals and Crimping Tools under the Dowell's Brand	in 1963

and finally **3D** CRIMPING TECHNOLOGY SYSTEM with **3D** range of products from 1979. Mr. G. S. Patel supported by technical expertise from his son Mr. A. G. Patel an Electrical Engineer, pioneered this technology in India, which has applications in Electrical Cable joining.

The Introduction of **3D** Brand terminals, tools and accessories are the result of long awaited demand from the users, for the products with international standard backed by advanced technology. Mr. G. S. Patel and Mr. A. G. Patel took up the challenge with professional approach and established a manufacturing set-up, which is the only plant of its kind in India offering wide range of products for cable termination.

The Present

In **billets Elektro Werke Ltd.**, we design, develop manufacture and market our **3D** Brand CRIMPING TECHNOLOGY SYSTEM including Cable Joining Accessories, which are produced from basic Copper Cathodes to finished products under ONE ROOF.

Crimping is an advance technique of securing a Terminal/Connector to a conductor by using the special tool to give a perfect electrical joint for the cable to withstand any adverse condition.

Management: **billets Elektro Werke Ltd.** is professionally managed and at the helm are Mr. Ashok G. Patel, Managing director with over 25 years experience in the engineering field and Mr. Chirag A. Patel, Executive director with over 5 years experience.

Product Range:

CRIMPING TOOLS | CONNECTORS | TUBULAR CABLE LUGS | STAMPED CABLE LUGS |
TUBULAR END SLEEVES For CABLES | APPLICATORS For HARNESS MANUFACTURERS. |
WIRE/CABLE CUTTING TOOLS | CRIMPING TOOLS

We have successfully developed and established a market for import substitutes in India.

80% of our sales revenue comes from the international market and rest from the domestic market in following categories: Importers and Wholesalers | Electricity Boards | Projects Refineries | OEMs | etc.

R&D

Accrued technical know-how from reputed manufacturers abroad in different areas of production and quality control with intense dedication to Research & Development during the past many years have enabled us to stay ahead of competition.

Recognition

We have proven recognition from satisfied Overseas Customer in Australia, New Zealand, Singapore, Myanmar, Hong Kong, Gulf Countries, South Africa, Kenya, Spain, Netherlands, Ireland and UK. who have been buying our products for the past 15 years steadfast with implicit faith in our quality and services.

ISO 9001 - 2000 we have standardized our quality control and inspection procedures as per ISO 9001 - 2000 and have also been certified by TUV.

We have also been winning several Export Excellence Awards from the government of India / EEPC.



The Crimping people... since 1960

The Future

We are in the process of expanding our product profile. we have also expanded our manufacturing capacity in the form of new tooling, automization and quality control equipments. Our aim for the future is to make  Cable Lugs and Tools a globally recognized Brand.

Our Motto

The dimensions of our  brand are

1. Quality 2. Consistency of Quality 3. Assured Deliveries.

and to understand the exact needs of the users to recommend/guide them in the correct direction with latest available technique in cable Termination.

Quality Benefits of 3D Terminals

Don't compromise on quality for the sake of price. A cheap quality terminal can affect the optimum functioning of your product. At **billets Elektro Werke Ltd.** we have an experience of more than 40 years in designing and manufacturing cable terminals and crimping tools. We have stringent in-house quality and inspection standards. And we don't compromise...

- **Conductivity:** All our input raw materials are checked for conductivity. We only use ETP grade, 99.9% conductivity copper and 60% conductivity aluminum . Incoming material is checked for conductivity and dimensional accuracy.
- **Finish:** All terminals go through deburring and polishing operations to eliminate all sharp edges, which may otherwise hinder fixation on the conductor.
- **Accuracy:** Our tool room has two wire cutting EDM's (Charmilles, Germany), a machining center (Haas, USA), and two spark erosion machines, besides a wide array of lathes, milling machines, drilling machines, grinding machines etc. Our press tools are designed keeping in mind high accuracy. Productivity and quality. The result are lugs manufactured within the dimensional tolerance.

- **Brazing:** we use high quality brazing wire containing 2% silver. This ensures a high flowing rate after melting and an even layer. This leaves a brazing seam with no lumps that spoil the finish of the terminal or affect the crimpability. We also normalize the terminals after brazing and conduct a bend test at the seam to ensure that there is no cracking.



- **Crimpability:** We ensure that our material is at the optimum softness so that operator can crimp the terminal with minimal effort, at the same time ensures that it is hard enough to sustain deformation.



- **Plating:** Our terminals have a tin coating of minimum 5 microns to ensure a shelf life of at least two years. Thickness is checked by Coulometric testing and salt spray tests.



- **Insulation:** Our insulation does not show any stress marks or colour changes even with extreme crimping. We also conduct heat aging and dielectric tests to ensure that the insulation does not degrade in high temperature environments.





The Crimping people... since 1960

Frequently Asked Questions

1. Which material is used for insulation of sheet metal terminals?
We use sleeves made out of PVC for insulating sheet metal terminals. The operating temperature for these lugs is from 60 degrees C to 100 degrees C.
For high temperature applications we can also provide Nylon or Polycarbonate insulating sleeves. For applications where there is a chance of the sleeve coming off due to vibrations (eg railway locomotive) we use a cooper sleeve under the PVC insulation, for the enhancing the rigidity.
2. Why is the colour of insulation different for various cable sizes?
As per international practice in use, **Red** colour is for terminals of 1.5 Sq.mm, **Blue** colour is for terminals of 2.5 Sq.mm & **Yellow** colour is for terminals of 4-6 Sq.mm,
3. What are the Indian standard specifications for our products?
Indian standard specifications are formulated for Aluminum terminals only. At present specifications for copper or sheet metal terminals are not formulated.
IS 8308 - 1993 covers Aluminum In Line Connectors & IS 8309 - 1993 covers Aluminum Tubular Terminal Ends.
We however have obtained license for aluminum cable lugs only.
We have also developed lugs and connectors as per DIN specifications, however we don't have certification for the same.
4. How do we know the purity of copper or Aluminum used in our products?
We manufacture our copper lugs and connectors from cathodes obtained from LME approved warehouses only. Our aluminum lugs and connectors are manufactured from ISI certified tube manufacturers, who use aluminum ingots of the highest purity.
We have in-house testing facilities to check the conductivity for copper and aluminum.
Does 99% copper content guarantee 99% IACS conductivity?
No. Conductivity is affected by the type of impurities content in balance 1%. It has been observed that 0.5% arsenic may bring down the conductivity to the tune of 50% to 60%
5. How to select the right lug for the right cable size?

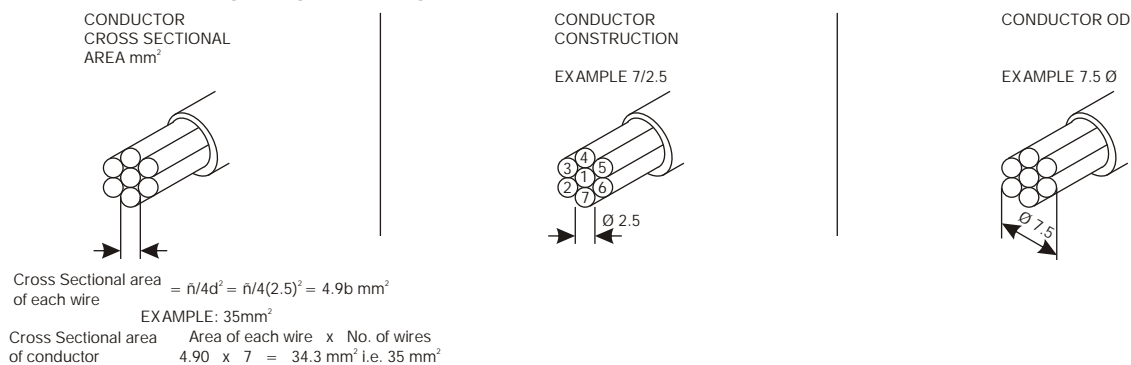





6. Flexible wire does not go into the barrel of the same size of terminal?
Outer diameter of flexible wire is maximum compared to the other (stranded or solid) shape. Our terminals are designed to easily receive stranded wires. It becomes difficult to insert the flexible wire into the barrel. Best practice is to form the wire with forming dies or use one higher size of terminal (however that may cause flashing). Use of terminals having easy entry barrels will also provide ease of insertion.
7. Why serrations are provided?
Serrations help in cutting oxide film formed over the conductor. (In case of aluminium the oxide film is formed at normal temperature or humidity). Serrations also help in providing better grip of the joint. However, we have taken the pull off test over the same size of crimped terminal, with and without serrations. Though the terminals without serrations withstand lesser pull off load, it is will within the limits of 4Kg./Sq.mm. The use of a corrosion-inhibiting compound (3D-112, 3D-113) is a better option for breaking the oxide layer on the conductor.
8. How can corrosion after crimping be reduced or prevented?
It can be prevented or reduced by applying special corrosion inhibiting compounds between the surfaces of different material being used in electrical circuit.



The Crimping people... since 1960

Crimping Techniques

1. How Corrosion Inhibiting Compound (3D-112, 3D-113) should be used?
Compound should be freely applied over the stripped portion of wire and also on the inside surface of barrel.
Excess compound will seal the barrel mouth after crimping and in turn prevent the ingress of moisture or other contaminated substances present in the surrounding atmosphere.
Compound is recommended to be used when aluminium lug is used with aluminium conductor.
2. How can we know that the crimped joint is proper or not?
A properly crimped joint is one in which the compressed section of the joint is so tightly packed that it almost becomes homogenous.
It can be ascertained by:
Pull Off Load Test - Crimped joint should withstand the pull off load of 4Kg./Sq.mm. Say for 240 Sq.mm. cable, it should withstand $240 \times 4 = 960$ Kg.
Joint Resistance - As per IS 8337 the resistance of crimped joint on aluminium wire should not be more than the resistance across the length of the conductor equal to the length of barrel of the terminal.
Visual Inspection Cut a section of the crimped portion and examine the section for air gaps between the conductors, or between the ID wall of the lug and the conductors. Presence of air gaps indicates that the crimping is not homogenous. As shown in the picture:

3. Can insulated terminals be crimped with the tools meant for non-insulated terminals?
NO. The tools designed for Non-insulated terminals will not properly crimp the terminals. It will also damage the insulating sleeve. The same logic applies for
4. What should be the direction of crimping, when crimping multiple crimps on longer barrel lugs?
The direction of crimping should always be away from the palm portion of the barrel in the case of lugs, and should start from the centre in the case of connectors.

5. What should be the stripping length of conductor?
It should be slightly more than the barrel length, which will give the rough idea whether the conductor has been fully inserted or not. However, wherever possible, it is recommended to use the terminals having inspection vent, which will show if the conductor is fully inserted or not.
6. Terminals having bigger stud hole (say 16-mm) can be used with smaller bolt (say 12-mm)?
NO. When the smaller bolt is used with the terminal having higher stud hole, the bolt washer starts forming dish shape while tightening and does not exert proper pressure on the palm. This results in improper contact, which can lead to failure of the termination due to excess heat generation. This is illustrated by the picture below. The electrical contractor in this case had terminated the lug on a fuse gear with a considerably smaller area, resulting in melting of the lug.

7. What is the importance of spring washer in any bolted connections?
When the current flows through any conductive metal, heat is generated. The conducting metal expands when the heat is generated and contracts when the current stops flowing. Spring washer helps in maintaining proper pressure on bolted joints during expansion and contraction.
8. Can terminals be crimped without the recommended crimping tools?
Our lugs and tools are designed to offer the best possible electrical and mechanical joint. We have found that some electricians and electrical contractors prefer using hammers or pliers to crimp a lug. This technique brought about just to save some expense, is absolutely NOT recommended by us. Mainly because hammering a terminal will not provide the adequate pull-off load strength.

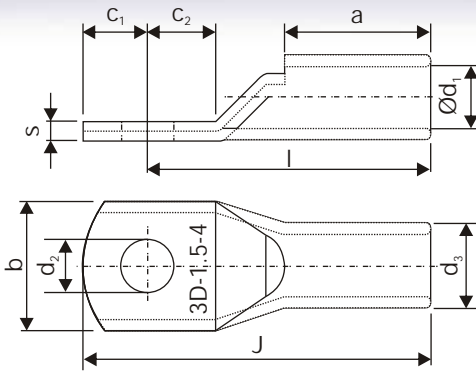

The Crimping people... since 1960

Tubular Cable Lugs

Standard Type, With Inspection Hole
for Copper Conductors
Material: E-copper
Surface: Tin Plated



Conductor mm ²	Bolt Ø	3D CAT NO.	Dimensions In mm										Tools	pcs
			Barrel ID	Barrel OD	Stud Size	Palm Width	Palm thickness	Barrel Length	Stud Distance From Top	Stud Distance From Barrel	Crimp Distance	Total Length		
			<i>d₁</i>	<i>d₃</i>	<i>d₂</i>	<i>b</i>	<i>s</i>	<i>a</i>	<i>C₁</i>	<i>C₂</i>	<i>l</i>	<i>J</i>		
1.5	M 4	3D-2622	1.8	3.7	4.2	8	1.0	5	4	5	12	16	3D-17	100
	M 5	3D-2623	1.8	3.7	5.2	8	1.0	5	4	5	12	16	3D-2	
	M 6	3D-2624	1.8	3.7	6.5	10	0.8	5	5	6	13	18	3D-117 3D-108	
2.5	M 4	3D-2625	2.4	4	4.2	8	1.0	7	4	5	14	18	3D-17	100
	M 5	3D-2627	2.4	4	5.2	8	1.0	7	4	5	14	18	3D-2	
	M 6	3D-2628	2.4	4	6.5	10	0.8	7	5	6	15	20		
	M 8	3D-2629	2.4	4	8.2	11	0.7	7	7	8	17.5	24		
4	M 5	3D-2630	3.1	4.8	5.2	10	1.0	7	5	6	15	20	3D-17	100
	M 5	3D-2632	3.1	4.8	5.2	9	1.0	7	5	6	15	20	3D-2	
	M 6	3D-2631	3.1	4.8	6.5	10	1.0	7	5	6	15	20	3D-117	
	M 8	3D-2633	3.1	4.8	8.2	12	0.8	7	6.5	8.5	17.5	24	3D-108	
6	M 5	3D-2634	3.8	5.5	5.2	10	1.2	9	5	6	18	23	3D-17	100
	M 6	3D-2635	3.8	5.5	6.2	10	1.2	9	5	6	18	23	3D-2	
	M 8	3D-2637	3.8	5.5	8.4	12	1.0	9	6	9	21	27		
10	M 5	3D-2642	4.5	6.2	5.2	12	1.2	9	6	7	19	25	3D-2	100
	M 6	3D-2643	4.5	6.2	6.5	12	1.2	9	6	7	19	25	3D-88	
	M 8	3D-2645	4.5	6.2	8.4	12	1.2	9	6	9	21	27	3D-117 3D-108	
16	M 5	3D-2652	5.4	7.1	5.2	12	1.4	12	7	7	23	30	3D-2	100
	M 6	3D-2653	5.4	7.1	6.5	12	1.4	12	7	7	23	30		
	M 8	3D-2655	5.4	7.1	8.4	12	1.4	12	7	9	25	32		
25	M 6	3D-2663	6.8	8.8	6.5	13	2.0	12	7	7	23	30	3D-88	
	M 8	3D-2665	6.8	8.8	8.4	13	2.0	12	7	9	25	32	3D-117	
	M 8	3D-2666	6.8	8.8	8.4	16	1.6	12	10	11	27	37	3D-108	
	M 10	3D-2668	6.8	8.8	10.5	16	1.6	12	10	11	27	37	3D-100	
	M 12	3D-2670	6.8	8.8	13	18	1.4	12	12	13	29	41		





The Crimping people... since 1960

Tubular Cable Lugs

Standard Type, With Inspection Hole
for Copper Conductors
Material: E-copper
Surface: Tin Plated

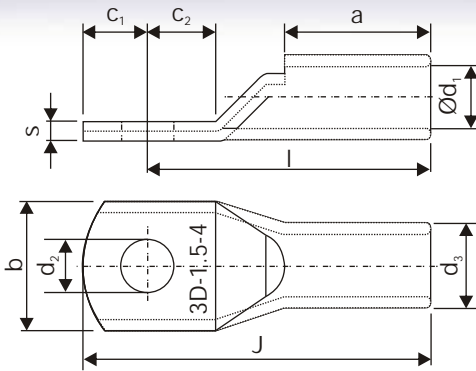

Conductor mm ²	Bolt Ø	3D CAT NO.	Dimensions in mm										Tools	pcs
			Barrel ID	Barrel OD	Stud Size	Palm Width	Palm thickness	Barrel Length	Stud Distance From Top	Stud Distance From Barrel	Crimpage Distance	Total Length		
			<i>d₁</i>	<i>d₃</i>	<i>d₂</i>	<i>b</i>	<i>s</i>	<i>a</i>	<i>C₁</i>	<i>C₂</i>	<i>l</i>	<i>J</i>		
35	M 6	3D-2673	8.2	10.6	6.5	15	2.4	12	9	9	26	35	3D-117	100
	M 6	3D-2674	8.2	10.6	6.5	15	2.4	15	9	9	29	38	3D-88	
	M 8	3D-2676	8.2	10.6	8.4	15	2.4	12	9	9	26	35	3D-108	
	M 8	3D-2677	8.2	10.6	8.4	15	2.4	15	9	9	29	38	3D-100	
	M 10	3D-2679	8.2	10.6	10.2	15	2.4	15	9	11	31	40		
	M 10	3D-2680	8.2	10.6	10.5	18	2.0	12	10	11	28	38		
	M 10	3D-2681	8.2	10.6	10.5	18	2.0	15	10	11	31	41		
	M 12	3D-2683	8.2	10.6	13	20	1.8	15	12	13	33	45		
50	M 6	3D-2687	10	12.8	6.5	18	2.8	16	10	11	33	43	3D-117	100
	M 8	3D-2689	10	12.8	8.4	18	2.8	16	10	11	33	43	3D-88	
	M 10	3D-2691	10	12.8	10.5	18	2.8	16	10	11	33	43	3D-100	
	M 12	3D-2693	10	12.8	13	20	2.5	16	12	13	35	47		
	M 12	3D-2695	10	12.8	12.5	18	2.8	16	12	13	35	47		
	70	M 6	3D-2697	11.2	14.7	6.5	21	3.5	18	12	13	38	50	
M 8		3D-2698	11.2	14.7	8.4	21	3.5	18	12	13	38	50	3D-88	
M 10		3D-2699	11.2	14.7	10.5	21	3.5	18	12	13	38	50	3D-108	
M 12		3D-2700	11.2	14.7	13	21	3.5	18	12	13	38	50	3D-100	
M 14		3D-2704	11.2	14.7	15	28	2.2	18	16	16	41	57		
M 16		3D-2705	11.2	14.7	17	28	2.2	18	16	16	41	57		
95		M 8	3D-2708	13.5	17.4	8.4	25	3.9	20	13	13	42	55	3D-117
	M 10	3D-2709	13.5	17.4	10.5	25	3.9	20	13	13	42	55	3D-100	
	M 12	3D-2712	13.5	17.4	13	25	3.9	20	13	13	42	55		
	M 14	3D-2713	13.5	17.4	15	28	3.2	20	16	16	45	61		
	M 16	3D-2715	13.5	17.4	17	28	3.2	20	16	16	45	61		
	120	M 8	3D-2716	15.0	19.4	8.4	28	4.4	22	14	14	46	60	3D-117
M 10		3D-2717	15.0	19.4	10.5	28	4.4	22	14	14	46	60	3D-88	
M 12		3D-2719	15.0	19.4	13	28	4.4	22	14	14	46	60	3D-108	
M 14		3D-2721	15.0	19.4	15	28	4.4	22	16	16	48	64	3D-100	
M 16		3D-2722	15.0	19.4	17	28	4.4	22	16	16	48	64		





The Crimping people... since 1960

Tubular Cable Lugs

Standard Type, With Inspection Hole for Copper Conductors

Material: E-copper

Surface: Tin Plated

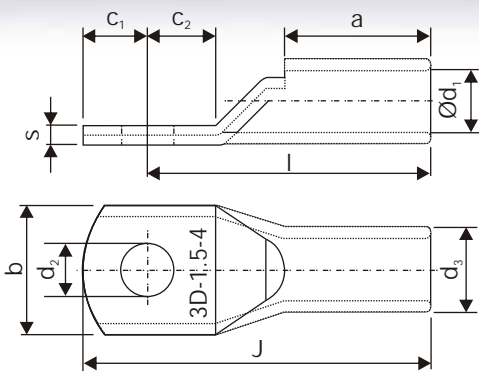

Conductor mm ²	Bolt Ø	3D CAT NO.	Dimensions in mm										Tools	pcs
			Barrel ID	Barrel OD	Stud Size	Palm Width	Palm thickness	Barrel Length	Stud Distance From Top	Stud Distance From Barrel	Crimpage Distance	Total Length		
			d_1	d_3	d_2	b	s	a	C_1	C_2	l	J		
150	M 8	3D-2726	16.5	21.2	8.4	30	4.7	26	16	16	53	69	3D-117	10
	M 10	3D-2727	16.5	21.2	10.5	30	4.7	26	16	16	53	69	3D-88	
	M 12	3D-2729	16.5	21.2	13	30	4.7	26	16	16	53	69	3D-108	
	M 14	3D-2732	16.5	21.2	15	30	4.7	26	16	16	53	69	3D-100	
	M 16	3D-2733	16.5	21.2	17	30	4.7	26	16	16	53	69		
	M 20	3D-2734	16.5	21.2	21	34	4.3	26	19	23	60	79		
185	M 10	3D-2736	18.5	23.5	10.5	34	5	32	17	17	61	78	3D-117	10
	M 12	3D-2737	18.5	23.5	13	34	5	32	17	17	61	78	3D-108	
	M 14	3D-2738	18.5	23.5	15	34	5	32	17	17	61	78	3D-100	
	M 16	3D-2741	18.5	23.5	17	34	5	32	17	17	61	78		
	M 20	3D-2743	18.5	23.5	21	34	5	32	17	17	61	78		
240	M 10	3D-2747	21	26.5	10.5	38	5.5	38	20	20	72	92	3D-117	10
	M 12	3D-2748	21	26.5	13	38	5.5	38	20	20	72	92	3D-100	
	M 14	3D-2749	21	26.5	15	38	5.5	38	20	20	72	92		
	M 16	3D-2750	21	26.5	17	38	5.5	38	20	20	72	92		
	M 20	3D-2751	21	26.5	21	38	5.5	38	20	20	72	92		
300	M 12	3D-2754	23.5	30	13	43	6.5	42	22	22	79	101	3D-117	5
	M 14	3D-2755	23.5	30	15	43	6.5	42	22	22	79	101		
	M 16	3D-2756	23.5	30	17	43	6.5	42	22	22	79	101		
	M 20	3D-2757	23.5	30	21	43	6.5	42	22	22	79	101		
400	M 12	3D-2760	26.8	34.8	13	50.1	8	44	26	26	88	114	3D-117	5
	M 14	3D-2761	26.8	34.8	15	50.1	8	44	26	26	88	114	3D-100	
	M 16	3D-2762	26.8	34.8	17	50.1	8	44	26	26	88	114		
	M 16	3D-2763	26.8	34.8	17	50.1	8	44	22	27	83	105		
	M 20	3D-2764	26.8	34.8	21	50.1	8	44	22	27	83	105		
	M 20	3D-2765	26.8	34.8	21	50.1	8	44	26	26	88	114		
500	M 16	3D-2769	30	39	17	56	9	48	28	28	96	124	3D-120	5
	M 20	3D-2770	30	39	21	56	9	48	28	28	96	124		
630	M 16	3D-2773	35	45	17	65	10	56	33	33	111	144	3D-120	5
	M 20	3D-2774	35	45	21	65	10	56	33	33	111	144		





The Crimping people... since 1960

Tubular Cable Lugs

Extra Long Type,
W/O Inspection Hole
Material: E-copper
Surface: Tin Plated

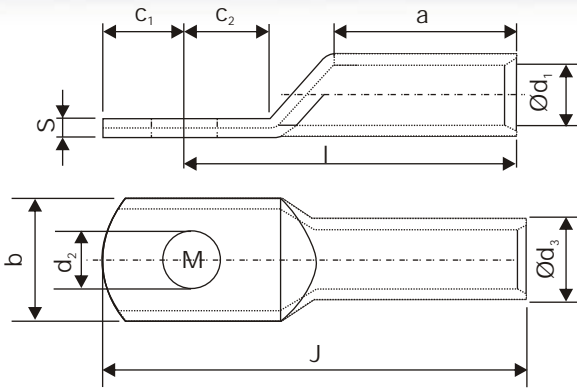

Conductor mm ²	Bolt Ø	3D CAT NO.	Dimensions in mm										Tools	pcs
			Barrel ID	Barrel OD	Stud Size	Palm Width	Palm thickness	Barrel Length	Stud Distance From Top	Stud Distance From Barrel	Crimpage Distance	Total Length		
			d ₁	d ₃	d ₂	b	s	a	C ₁	C ₂	l	J		
25	M 8	3D-2340	7	9	8.2	13	2.0	16	8	12	33	41	3D-7	50
	M 10	3D-2340A	7	9	10.2	13	2.0	16	8	12	33	41	3D-88	
35	M 8	3D-2341	8	10.6	8.2	15	2.6	20	9	14	39	48	3D-7	50
	M 10	3D-2341A	8	10.6	10.2	15	2.6	20	9	14	39	48	3D-124	
50	M 8	3D-2342	9.2	12.2	8.2	17	3.0	26	10	16	49	59	3D-7	50
	M 10	3D-2342A	9.2	12.2	10.2	17	3.0	26	10	16	49	59	3D-88	
	M 12	3D-2342B	9.2	12.2	12.7	17	3.0	26	10	16	49	59		
70	M 10	3D-2343	11.5	15	10.2	20	3.5	28	12	19	54	66	3D-7	25
	M 12	3D-2343A	11.5	15	12.7	20	3.5	28	12	19	54	66		
95	M 12	3D-2344	12.8	17	12.7	24	4.2	32	12	20	62	74	3D-7	25
	M 16	3D-2344A	12.8	17	16.2	24	4.2	32	12	20	62	74	3D-124	
120	M 12	3D-2345	14.8	19.6	12.7	28	4.8	35	14	23	68	82	3D-7	25
	M 16	3D-2345A	14.8	19.6	16.2	28	4.8	35	14	23	68	82	3D-88	
150	M 12	3D-2346	16	21.2	12.7	30	5.2	38	14	24	72	86	3D-7	25
	M 16	3D-2346A	16	21.2	16.2	30	5.2	38	14	24	72	86	3D-108	
185	M 12	3D-2347	18	24	12.7	34	6.0	43	17	23	78	95	3D-7	20
	M 16	3D-2347A	18	24	16.2	34	6.0	43	17	23	78	95	3D-108	
	M 20	3D-2347B	18	24	21	34	6.0	43	17	23	78	95	3D-124	
240	M 16	3D-2348	22	28	16.2	40	6.0	50	20	30	92	112	3D-7	10
	M 20	3D-2348A	22	28	21	40	6.0	50	20	30	92	112		
300	M 16	3D-2998	24.5	32	17	48	7.5	50	19	22	97	119	3D-7	5
	M 20	3D-2999	24.5	32	21	48	7.5	50	19	22	100	122	3D-124	
400	M 16	3D-3000	27.5	38.5	17	55	11.0	70	25	25	115	140	3D-124	5
	M 20	3D-3000A	27.5	38.5	21	55	11.0	70	25	25	115	140		



The Crimping people... since 1960

Tubular Cable Lugs

Economy Series W/O Inspection Hole
for Aluminum Conductors
Material: E-Copper
Surface: Tin Plated

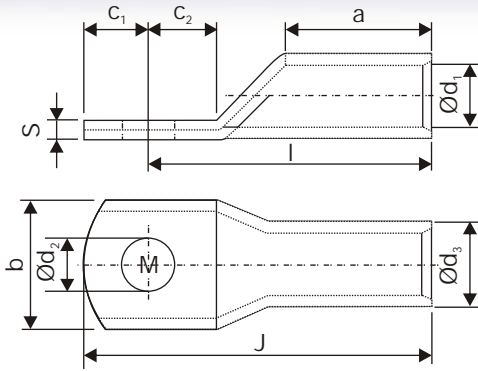

Conductor mm ²	Bolt Ø	3D CAT NO.	Dimensions in mm										Tools	pcs
			Barrel ID	Barrel OD	Stud Size	Palm Width	Palm thickness	Barrel Length	Stud Distance From Top	Stud Distance From Barrel	Crimpage Distance	Total Length		
			d ₁	d ₃	d ₂	b	s	a	C ₁	C ₂	l	J		
2.5	M 5	3D-2501	2.3	3.8	5.2	9	1.0	7	5	5	15	20	3D-17 3D-2	100
4	M 6	3D-2502	3.1	4.8	6.4	11	1.0	7	6	6	16	22	3D-17 3D-2	100
6	M 6	3D-2503	3.8	5.5	6.4	11	1.0	9	6	6	18	24	3D-17 3D-2	100
10	M 6	3D-2504	4.5	6.2	6.4	11	1.3	9	6	6	18	24	3D-2	100
16	M 6	3D-2505	5.4	7.1	6.4	11	1.6	12	6	8	24	30	3D-2	50
25	M 6	3D-2506	7	9	6.4	13	2.0	12	8	12	29	37	3D-116	50
35	M 6	3D-2507	8	10	6.4	15	2.0	12	8	12	29	37	3D-116	50
	M 8	3D-2508	8	10	8.2	15	2.0	12	8	12	29	37	3D-88 3D-125	
50	M 6	3D-2509	9.2	11.2	6.4	16	2.0	16	9	12	36	45	3D-7	50
	M 8	3D-2510	9.2	11.2	8.2	16	2.0	16	9	12	36	45		
	M 10	3D-2511	9.2	11.2	10.2	16	2.0	16	9	12	36	45		
70	M 8	3D-2512	11.5	13.8	8.2	20	2.3	18	13	15	43	56	3D-116	25
	M 10	3D-2513	11.5	13.8	10.2	20	2.3	18	13	15	43	56	3D-88	
	M 12	3D-2514	11.5	13.8	12.7	20	2.3	18	13	15	43	56	3D-125	
95	M 10	3D-2515	12.8	15.6	10.2	23	2.8	20	13	15	45	58	3D-7	25
	M 12	3D-2516	12.8	15.6	12.7	23	2.8	20	13	15	45	58		
120	M 10	3D-2517	14.8	17.8	10.2	26	3.0	22	14	16	48	62	3D-116	25
	M 12	3D-2518	14.8	17.8	12.7	26	3.0	22	14	16	48	62	3D-88	
	M 16	3D-2519	14.8	17.8	16.2	26	3.0	22	14	16	48	62	3D-125	
150	M 10	3D-2520	16	19.6	10.2	28	3.6	26	15	18	55	70	3D-7	25
	M 12	3D-2521	16	19.6	12.7	28	3.6	26	15	18	55	70		
	M 16	3D-2522	16	19.6	16.2	28	3.6	26	15	18	55	70		
185	M 12	3D-2523	18	22	12.7	32	4.0	28	21	21	62	83	3D-116	20
	M 16	3D-2524	18	22	16.2	32	4.0	28	21	21	62	83	3D-125	
240	M 16	3D-2525	22	26	16.2	38	4.0	34	24	24	73	97	3D-116	10
	M 20	3D-2526	22	26	20.3	38	4.0	34	24	24	73	97		
300	M 16	3D-2527	24	28.7	16.2	42	4.7	37	25	25	78	103	3D-116	5
	M 20	3D-2528	24	28.7	20.3	42	4.7	37	25	25	78	103	3D-125	
400	M 20	3D-2529	28	33.2	20.3	49	5.2	44	27	27	89	116	3D-116	5
													3D-125	
500	M 20	3D-2530	30	36	20.3	53	6.0	48	27	27	95	122	3D-121	5
630	M 20	3D-2531	35	41.5	20.3	61	6.5	53	31	33	106	137	3D-121	5
800	BLK	3D-2532	39	46.3		67	7.3	68		75		165	3D-121	10
1000	BLK	3D-2533	43	53.8		76	10.8	90		90		210	3D-121	10



The Crimping people... since 1960

Tubular Cable Lugs

Standard New Type, W/O Inspection Hole
for Copper Conductors

Material: Electrolytic Copper
Surface: Tin Plated

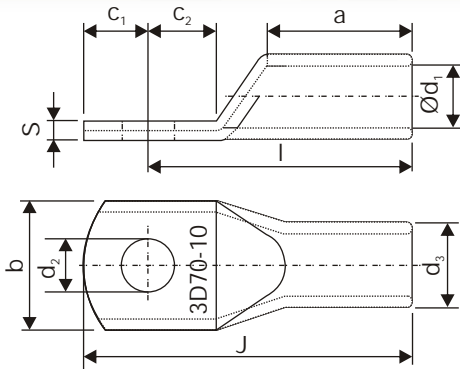

Conductor mm ²	Bolt Ø	3D CAT NO.	Dimensions In mm										Tools	pcs
			Barrel ID	Barrel OD	Stud Size	Palm Width	Palm thickness	Barrel Length	Stud Distance From Top	Stud Distance From Barrel	Crre-page Distance	Total Length		
			d_1	d_3	d_2	b	s	a	C_1	C_2	l	J		
6	M 5	3D-2149	3.5	6.5	5.5	10	2.3	9	6.5	7.5	21	27.5	3D-2	100
	M 6	3D-2150	3.5	6.5	6.5	12	1.9	9	6.5	7.5	21	27.5	3D-17	
	M 8	3D-2110	3.5	6.5	8.5	15	1.5	9	10	10	23	33	3D-117	
	M 10	3D-2158	3.5	6.5	10.5	17	1.4	9	12	12	25	37	3D-108	
	M 12	3D-2159	3.5	6.5	13	19	1.2	9	13	13	28	41		
10	M 5	3D-2041	4.5	7	5.5	12	1.8	10	6.5	7.5	22	28.5	3D-2	100
	M 6	3D-2183	4.5	7	6.5	12	1.8	10	6.5	7.5	22	28.5	3D-117	
	M 8	3D-2184	4.5	7	8.5	15	1.5	10	10	10	25	35	3D-88	
	M 10	3D-2160	4.5	7	10.5	17	1.3	10	12	12	27	39	3D-108	
	M 12	3D-2161	4.5	7	13	19	1.2	10	13	13	29	42		
16	M 5	3D-2185	5.5	8.5	5.5	12	2.7	13	5.5	6.5	26	31.5	3D-2	100
	M 6	3D-2186	5.5	8.5	6.5	12	2.7	13	6.25	7.5	27	33.25	3D-117	
	M 8	3D-2187	5.5	8.5	8.5	15	2.2	13	8.5	9.5	29	37.5	3D-88	
	M 10	3D-2162	5.5	8.5	10.5	17	1.9	13	10.5	11.5	31	41.5	3D-108	
	M 12	3D-2163	5.5	8.5	13	19	1.7	13	12	13	33	45		
25	M 5	3D-2165	7	10	5.5	14	2.8	15	7.5	7.5	30	37.5	3D-117	25
	M 6	3D-2189	7	10	6.5	14	2.8	15	7.5	7.5	30	37.5	3D-88	100
	M 8	3D-2190	7	10	8.5	16	2.5	15	10	10	32	42	3D-108	100
	M 10	3D-2191	7	10	10.5	18	2.2	15	12	12	34	46		100
	M 12	3D-2166	7	10	13	19	2.1	15	13	13	35	48		25
	M 14	3D-2167	7	10	15	21	1.9	15	14.5	14.5	38	52.5		25
35	M 6	3D-2192	8.5	12	6.5	17	3.3	17	7.5	7.5	32	39.5	3D-117	100
	M 8	3D-2193	8.5	12	8.5	17	3.3	17	10	10	34	44	3D-88	100
	M 10	3D-2014	8.5	12	10.5	19	2.9	17	12	12	37	49	3D-100	100
	M 12	3D-2168	8.5	12	13	21	2.6	17	13	13	38	51		100
	M 14	3D-2169	8.5	12	15	21	2.6	17	14.5	14.5	40	54.5		25
	M 16	3D-2006	8.5	12	17	26	2.1	17	16	16	42	58		25





The Crimping people... since 1960

Tubular Cable Lugs

Standard New Type, W/O Inspection Hole for Copper Conductors

Material: Electrolytic Copper
Surface: Tin Plated

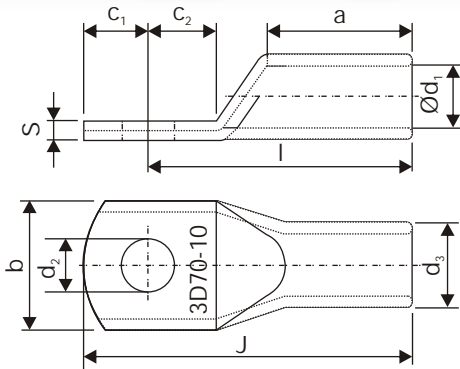

Conductor mm ²	Bolt Ø	3D CAT NO.	Dimensions In mm										Tools	pcs
			Barrel ID	Barrel OD	Stud Size	Palm Width	Palm thickness	Barrel Length	Stud Distance From Top	Stud Distance From Barrel	Crre-page Distance	Total Length		
			<i>d₁</i>	<i>d₃</i>	<i>d₂</i>	<i>b</i>	<i>s</i>	<i>a</i>	<i>C₁</i>	<i>C₂</i>	<i>l</i>	<i>J</i>		
50	M 6	3D-2001	10	14	6.5	20	3.7	19	10	10	37	47	3D-117	25
	M 8	3D-2003	10	14	8.5	20	3.7	19	10	10	37	47	3D-88	50
	M 10	3D-2004	10	14	10.5	20	3.7	19	12	12	39	51	3D-100	50
	M 12	3D-2170	10	14	13	23	3.2	19	13	13	43	56		50
	M 14	3D-2171	10	14	15	23	3.2	19	14.5	14.5	45	59.5		25
	M 16	3D-2007	10	14	17	28	2.7	19	16	16	46	62		25
	M 20	3D-2008	10	14	21	30	2.5	19	19	19	48	67		25
70	M 6	3D-2005	12	16.5	6.5	23	4.3	21	10	10	43	53	3D-117	25
	M 8	3D-2121	12	16.5	8.5	23	4.3	21	10	10	43	53	3D-88	50
	M 10	3D-2164	12	16.5	10.5	23	4.3	21	12	12	44	56	3D-100	50
	M 12	3D-2188	12	16.5	13	23	4.3	21	13	13	46	59		50
	M 14	3D-2172	12	16.5	15	23	4.3	21	14.5	14.5	48	62.5		25
	M 16	3D-2173	12	16.5	17	28	3.6	21	16	16	50	66		25
	M 20	3D-2129	12	16.5	21	30	3.3	21	19	19	53	72		25
95	M 8	3D-2015	13.5	18	8.5	26	4.2	25	12	12	48	60	3D-117	25
	M 10	3D-2018	13.5	18	10.5	26	4.2	25	12	12	48	60	3D-88	50
	M 12	3D-2019	13.5	18	13	26	4.2	25	13	13	49	62	3D-100	50
	M 14	3D-2174	13.5	18	15	26	4.2	25	14.5	14.5	51	65.5		25
	M 16	3D-2175	13.5	18	17	28	3.9	25	16	16	54	70.0		50
	M 20	3D-2130	13.5	18	21	36	3	25	22	22	60	82.0		25
120	M 8	3D-2020	15	19.5	8.5	28	4.3	26	14	14	51	65	3D-117	25
	M 10	3D-2021	15	19.5	10.5	28	4.3	26	14	14	51	65	3D-88	50
	M 12	3D-2022	15	19.5	13	28	4.3	26	14	14	51	65	3D-100	50
	M 14	3D-2023	15	19.5	15	28	4.3	26	15	15	52	67		25
	M 16	3D-2035	15	19.5	17	30	4.0	26	16	16	54	70		50
	M 20	3D-2176	15	19.5	21	36	3.326		22	22	63	85		25



The Crimping people... since 1960

Tubular Cable Lugs

Standard New Type, W/O Inspection Hole
for Copper Conductors

Material: Electrolytic Copper
Surface: Tin Plated

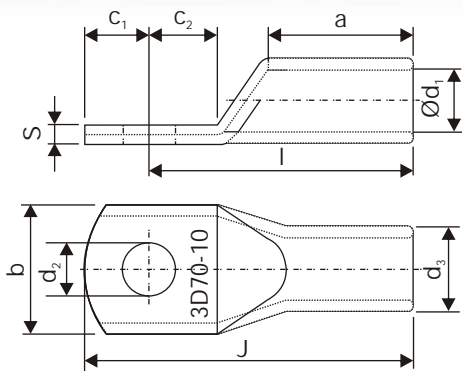

Conductor mm ²	Bolt Ø	3D CAT NO.	Dimensions in mm										Tools	pcs
			Barrel ID	Barrel OD	Stud Size	Palm Width	Palm thickness	Barrel Length	Stud Distance From Top	Stud Distance From Barrel	Crre-page Distance	Total Length		
			<i>d₁</i>	<i>d₃</i>	<i>d₂</i>	<i>b</i>	<i>s</i>	<i>a</i>	<i>C₁</i>	<i>C₂</i>	<i>l</i>	<i>J</i>		
150	M 8	3D-2036	16.5	21	8.5	31	4.2	30	14	14	56	70	3D-117	10
	M 10	3D-2037	16.5	21	10.5	31	4.2	30	14	14	56	70	3D-100	10
	M 12	3D-2038	16.5	21	13	31	4.2	30	15	15	57	72		25
	M 14	3D-2039	16.5	21	15	31	4.2	30	15	15	57	72		10
	M 16	3D-2040	16.5	21	17	31	4.2	30	16	16	58	74		10
	M 20	3D-2177	16.5	21	21	36	3.6	30	22	22	66	88		10
185	M 10	3D-2042	19	24	10.5	35	4.8	30	18	18	65	83	3D-117	10
	M 12	3D-2043	19	24	13	35	4.8	30	18	18	65	83	3D-100	10
	M 14	3D-2044	19	24	15	35	4.8	30	18	18	65	83		10
	M 16	3D-2045	19	24	17	35	4.8	30	18	18	65	83		25
	M 20	3D-2046	19	24	21	39	4.3	30	22	22	69	91		10
240	M 10	3D-2047	21	26	10.5	38	5	35	19	21.5	72	93.5	3D-117	10
	M 12	3D-2048	21	26	13	38	5	35	19	21.5	72	93.5	3D-100	10
	M 14	3D-2049	21	26	15	38	5	35	19	21.5	72	93.5		10
	M 16	3D-2050	21	26	17	38	5	35	19	21.5	72	93.5		25
	M 20	3D-2051	21	26	21	38	5	35	19	21.5	72	93.5		10
300	M 12	3D-2052	23.5	29.5	13	43	5.8	44	24	24	87	111	3D-117	5
	M 14	3D-2053	23.5	29.5	15	43	5.8	44	24	24	87	111	3D-100	
	M 16	3D-2122	23.5	29.5	17	43	5.8	44	24	24	87	111		
	M 20	3D-2131	23.5	29.5	21	43	5.8	44	24	24	87	111		
400	M 12	3D-2123	27	34	13	49	6.8	44	24	24	90	114	3D-117	5
	M 14	3D-2124	27	34	15	49	6.8	44	24	24	90	114	3D-100	
	M 16	3D-2125	27	34	17	49	6.8	44	24	24	90	114		
	M 20	3D-2109	27	34	21	49	6.8	44	24	24	90	114		





The Crimping people... since 1960

Tubular Cable Lugs

Extra wide palm type
With inspection Hole
Material - E Copper
Surface - Tin Plated

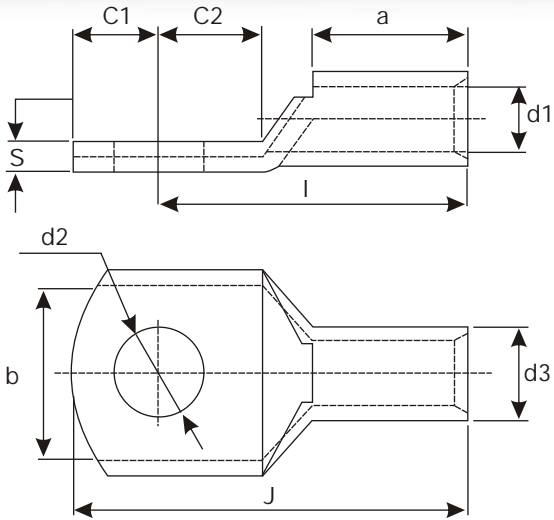

Conductor mm ²	Bolt \varnothing	3D Cat.No.	Dimensions in mm									
			Barrel ID <i>d1</i>	Barrel Length <i>a</i>	Palm Width <i>b</i>	Stud Size <i>d2</i>	Barrel OD <i>d3</i>	Stud Distance From top <i>C1</i>	Stud Distance From Barrel <i>C2</i>	Cree Page distance <i>I</i>	Total Length <i>J</i>	Palm thickness <i>S</i>
6	10	3D-2638	3.8	9	16	10.2	6.2	9	11	23	32	2.4
10	10	3D-2648	4.7	10	16	10.5	7.1	9	10	23	32	2.4
16	10	3D-2658	5.5	12	16	10.5	7.9	10	10	26	36	2.4
16	12	3D-2659	5.5	12	18	13	8.5	12	12	28	40	3

9

Tubular Cables Lugs

90° Angle Tube Dimensions as per DIN 46235
Material: Electrolytic Copper
Surface: Electro Tinned



Tubular Cable Lugs

45° Angle Tube Dimensions as per DIN 46235
Material: Electrolytic Copper
Surface: Electro Tinned



Compression Cable Lugs

For Copper Conductors According To Din 48 201,
Tube Dimensions : Din 46 235
Material : E Copper
Surface : Tin Plated, Alternatively Copper Finish
Type : With Two Long Holes In The Palm



The Crimping people... since 1960

Tubular Cable Lugs

Standard New Type, W/O Inspection Hole
for Copper Conductors
Material: Electrolytic Copper
Surface: Tin Plated

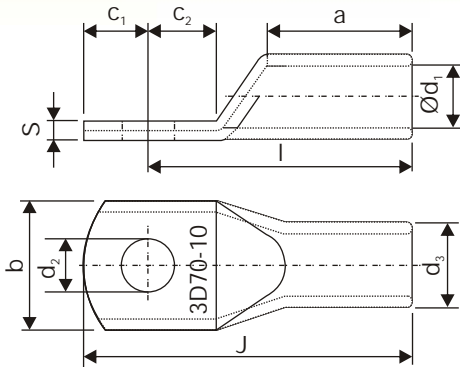

Copper Tubular Terminal Ends for solderless crimping to Copper Conductors

REF : I.C.F

Conductor mm ²	3D CAT NO.	Dimensions in mm									
		d ₁	a	b	d ₂	d ₃	C ₁	C ₂	k	J	s
17-5	3D-5042	6.0	14.0	11.9	5.2	8.5	6.0	10.0	3	33	2.5
17-6	3D-5043	6.0	14.0	11.9	6.5	8.5	6.0	10.0	3	33	2.5
17-8	3D-5044	6.0	14.0	16.0	8.2	8.5	9.0	11.0	3	37	1.7
17-10	3D-5045	6.0	11.0	16.0	10.2	8.5	9.0	11.0	3	37	1.7
23-5	3D-5046	7.1	18.0	14.3	5.2	10.2	7.0	10.0	4	39	3.1
23-6	3D-5047	7.1	18.0	14.3	6.5	10.2	7.0	10.0	4	39	3.1
23-8	3D-5048	7.1	18.0	14.3	8.2	10.2	7.0	10.0	4	39	3.1
23-10	3D-5049	7.1	18.0	19.0	10.2	10.2	10.0	12.0	4	44	2.2
23-29-5	3D-5050	8.0	18.0	16.3	5.2	11.7	8.0	11.0	4	41	3.7
29-6	3D-5051	8.0	18.0	16.3	6.5	11.7	8.0	11.0	4	41	3.7
29-8	3D-5052	8.0	18.0	16.3	8.2	11.7	8.0	11.0	4	41	3.7
29-10	3D-5053	8.0	18.0	20.0	10.2	11.7	11.0	14.0	4	47	2.8
29-13	3D-5054	8.0	18.0	20.0	13.0	11.7	11.0	14.0	4	47	2.8
45-5	3D-5055	9.8	18.0	19.3	5.2	13.7	10.0	10.0	5	43	3.9
45-6	3D-5056	9.8	18.0	19.3	6.5	13.7	10.0	10.0	5	43	3.9
45-8	3D-5057	9.8	18.0	19.3	8.2	13.7	10.0	10.0	5	43	3.9
45-10	3D-5058	9.8	18.0	19.3	10.2	13.7	10.0	10.0	5	43	3.9
45-13	3D-5059	9.8	18.0	22.0	13.0	13.7	11.0	14.0	5	48	3.2
57-6	3D-5060	11.1	24.0	22.2	6.5	15.8	11.0	15.0	6	56	4.7
57-8	3D-5061	11.1	24.0	22.2	8.2	15.8	11.0	15.0	6	56	4.7
57-10	3D-5062	11.1	24.0	22.2	10.2	15.8	11.0	15.0	6	56	4.7
57-13	3D-5062	11.1	24.0	22.2	13.0	15.8	11.0	15.0	6	56	4.7
75-6	3D-5063	12.6	24.0	25.0	6.5	17.8	13.0	15.0	6	58	5.2
75-8	3D-5064	12.6	24.0	25.0	8.2	17.8	13.0	15.0	6	58	5.2
75-10	3D-5065	12.6	24.0	25.0	10.2	17.8	13.0	15.0	6	58	5.2
75-13	3D-5066	12.6	24.0	25.0	13.0	17.8	13.0	15.0	6	58	5.2



The Crimping people... since 1960

Tubular Cable Lugs

Standard New Type, W/O Inspection Hole
for Copper Conductors
Material: Electrolytic Copper
Surface: Tin Plated

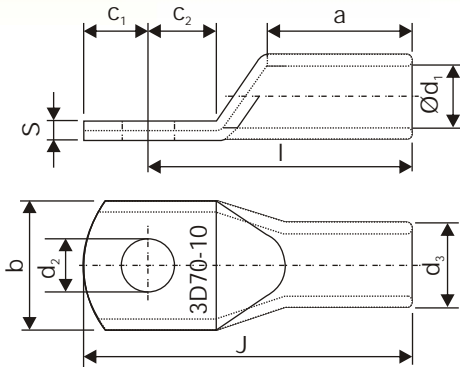

Copper Tubular Terminal Ends for solderless crimping to Copper Conductors

REF : I.C.F

Conductor mm ²	3D CAT NO.	Dimensions in mm									
		d ₁	a	b	d ₂	d ₃	C ₁	C ₂	k	J	s
90-6	3D-5067	13.7	24.0	26.9	6.5	19.1	13.0	16.0	6	59	5.4
90-8	3D-5068	13.7	24.0	26.9	8.2	19.1	13.0	16.0	6	59	5.4
90-10	3D-5069	13.7	24.0	26.9	10.2	19.1	13.0	16.0	6	59	5.4
90-13	3D-5070	13.7	24.0	26.9	13.0	19.1	13.0	16.0	6	59	5.4
110-6	3D-5071	15.3	24.0	29.6	6.5	20.9	15.0	17.0	6	62	5.6
110-8	3D-5072	15.3	24.0	29.6	8.2	20.9	15.0	17.0	6	62	5.6
110-10	3D-5073	15.3	24.0	29.6	10.2	20.9	15.0	17.0	6	62	5.6
110-13	3D-5074	15.3	24.0	29.6	13.0	20.9	15.0	17.0	6	62	5.6
146-8	3D-5075	17.5	29.0	34.0	8.2	24.0	17.0	18.0	7	71	6.5
146-10	3D-5076	17.5	29.0	34.0	10.2	24.0	17.0	18.0	7	71	6.5
146-12	3D-5077	17.5	29.0	34.0	13.0	24.0	17.0	18.0	7	71	6.5
146-16	3D-5078	17.5	29.0	34.0	17.0	24.0	17.0	18.0	7	71	6.5
183-10	3D-5079	19.8	29.0	38.2	10.2	26.9	18.0	21.0	8	76	7.1
183-12	3D-5080	19.8	29.0	38.2	13.0	26.9	18.0	21.0	8	76	7.1
183-16	3D-5081	19.8	29.0	38.2	17.0	26.9	18.0	21.0	8	76	7.1
225-10	3D-5082	21.9	29.0	42.2	10.2	29.7	21.0	24.0	9	83	7.8
225-12	3D-5083	21.9	29.0	42.2	13.0	29.7	21.0	24.0	9	83	7.8
225-16	3D-5084	21.9	29.0	42.2	17.0	29.7	21.0	24.0	9	83	7.8
225-20	3D-5085	21.9	29.0	42.2	21.0	29.7	21.0	24.0	9	83	7.8
299-12	3D-5086	25.4	29.0	48.5	13.0	34.0	24.0	26.0	10	89	8.6
299-16	3D-5087	25.4	29.0	48.5	17.0	34.0	24.0	26.0	10	89	8.6
299-20	3D-5088	25.4	29.0	48.5	21.0	34.0	24.0	26.0	10	89	8.6
366-12	3D-5089	28.0	38.0	53.6	13.0	37.6	27.0	29.0	11	105	9.6
366-16	3D-5090	28.0	38.0	53.6	17.0	37.6	27.0	29.0	11	105	9.6
366-20	3D-5091	28.0	38.0	53.6	21.0	37.6	27.0	29.0	11	105	9.6
437-12	3D-5092	30.5	38.0	59.1	13.0	41.7	29.0	32.0	12	111	11.2
437-16	3D-5093	30.5	38.0	59.1	17.0	41.7	29.0	32.0	12	111	11.2
437-20	3D-5094	30.5	38.0	59.1	21.0	41.7	29.0	32.0	12	111	11.2



The Crimping people... since 1960

Tubular Cable Lugs

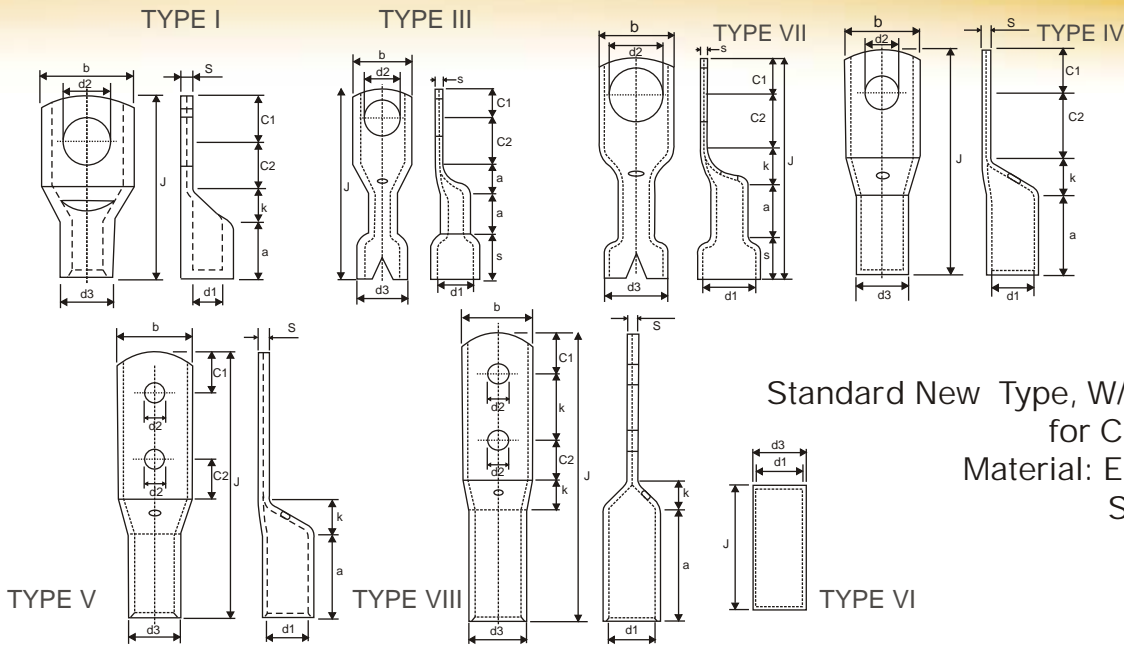

Standard New Type, W/O Inspection Hole
for Copper Conductors
Material: Electrolytic Copper
Surface: Tin Plated

Copper Tubular Terminal Ends for solderless crimping to Copper Conductors

REF : C.L.W

Conductor mm ²	3D CAT NO.	Dimensions in mm											
		d ₁	a	b	d ₂	d ₃	C ₁	C ₂	k	Type	J	s	
3-3	3D-5016	2.6	5.5	7.0	3.2	4.6	3.5	6.5		I	15.5	1.6	
3-3	3D-5017	2.6	5.5	5.0	3.2	4.6	2.5	6.5		I	14.5	2.0	
3-4	3D-5018	2.6	5.5	7.3	4.2	4.6	4.0	6.5		I	16.0	1.5	
3-4	3D-5019	2.6	5.5	8.0	4.2	4.6	4.0	6.5		I	16.0	1.4	
3-5	3D-5020	2.6	5.5	8.0	5.2	4.6	4.0	6.5		II	16.0	1.4	
3-6	3D-5021	2.6	8.0	10.0	6.2	5.0	5.0	10.0	3	III	34.0	1.4	
10-6	3D-5022	5.0	10.0	10.0	6.2	7.0	7.0	11.0	4	VII	40.0	2.0	
10-8	3D-5023	5.0	10.0	12.0	8.2	7.0	7.0	11.0	4	VII	40.0	1.6	
10-10	3D-5024	5.0	10.0	14.0	10.2	7.0	7.0	11.0	4	VII	40.0	1.4	
25-6	3D-5025	8.0	16.0	15.0	6.2	10.0	10.0	14.0	5	IV	45.0	2.0	
25-8	3D-5026	8.0	16.0	15.0	8.2	10.0	10.0	14.0	5	IV	45.0	2.0	
35-8	3D-5027	9.6	20.0	17.0	8.2	12.0	14.0	21.0	5	IV	60.0	2.4	
50-10	3D-5028	10.8	20.0	20.0	10.5	14.0	14.0	20.0	6	IV	60.0	3.2	
50-14	3D-5029	10.8	20.0	20.0	15.0	14.0	14.0	20.0	6	IV	60.0	3.2	
70-10	3D-5030	12.8	25.0	24.0	11.0	17.0	12.0	18.0	10	IV	65.0	4.2	
120-13	3D-5031	17.0	30.0	32.0	14.0	22.2	18.0	27.0	13	IV	88.0	5.2	
120-20	3D-5032	17.0	30.0	32.0	21.0	22.2	18.0	27.0	13	IV	88.0	5.2	
150-15	3D-5033	18.0	35.0	34.0	16.0	24.0	18.0	25.0	12	IV	90.0	6.0	
225-15	3D-5034	22.0	45.0	40.0	16.0	28.0	18.0	25.0	12	IV	100.0	6.0	
225-10X2	3D-5035	22.0	45.0	40.0	11.0	28.0	15.0	22.0	12	V	130.0	6.0	36
225-10	3D-5036	22.0	45.0	40.0	11.0	28.0	18.0	25.0	12	IV	100.0	6.0	
270-10X2	3D-5037	26.0	55.0	40.0	11.0	32.0	15.0	24.0	12	VIII	142.0	6.0	36
270	3D-5038	26.0				30.0				VI	70.0		
475-10X2	3D-5039	36.5	75.0	50.0	11.0	46.1	15.0	24.0	15	VIII	165.0	9.6	36
475-21	3D-5040	36.5	75.0	50.0	22.0	46.1	22.0	33.0	15	IV	145.0	9.6	
475-10	3D-5041	36.5	75.0	50.0	11.0	46.1	22.0	33.0	15	IV	145.0	9.6	



The Crimping people... since 1960

Tubular Cable Lugs

Standard New Type, W/O Inspection Hole
for Copper Conductors
Material: Electrolytic Copper
Surface: Tin Plated

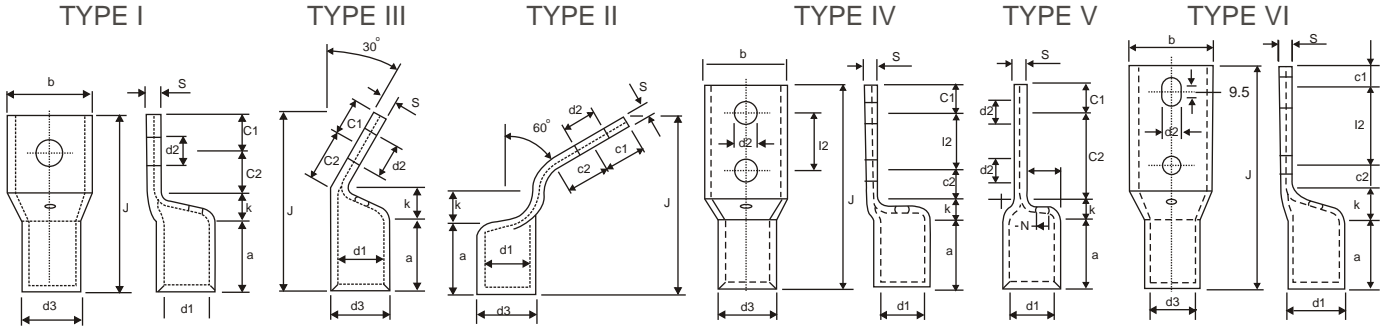

Copper Tubular Terminal Ends for solderless crimping to Copper Conductors

REF : D.L.W

Conductor mm ²	3D CAT NO.	Dimensions in mm											
		d ₁	a	b	d ₂	d ₃	C ₁	C ₂	k	Type	J	s	l ₂
133-10	3D-5000	17.0	27	32	10.3	22.2	19	28	8	I	82	5.2	
133-13	3D-5001	17.0	27	32	13.5	22.2	19	28	8	I	82	5.2	
133-13	3D-5002	17.0	27	32	13.5	22.2	14	19	7	I	67	5.2	
133-10	3D-5003	17.0	27	32	10.3	22.2	14	19	7	I	67	5.2	
133-10	3D-5004	17.0	27	32	10.3	22.2	14	19	12	II	62	5.2	
133-10	3D-5005	17.0	27	32	10.3	22.2	14	19	12	III	67	5.2	
133-8X2	3D-5006	17.0	27	32	8.7	22.2	11	11	8	IV	79	5.2	22.2
133-8X2	3D-5007	17.0	27	32	8.7	22.2	13	14	11	VI	109	5.2	44.4
270-16	3D-5008	24.6	40	46	16.6	31.7	21	22	11	I	94	7.1	
270-13	3D-5009	24.6	40	46	13.5	31.7	21	22	11	I	94	7.1	
270-13	3D-5010	24.6	35	46	13.5	31.7	21	22	15	III	86	7.1	
270-10X2	3D-5011	24.6	40	46	10.3	31.7	12	13	8	V	97	7.1	25.4
270-13X2	3D-5012	24.6	40	46	13.5	31.7	12	13	8	IV	105	7.1	31.7
400-17	3D-5013	29.3	47	53	17.4	37.2	22	29	10	I	108	7.9	
400-13	3D-5014	29.3	47	53	13.5	37.2	22	29	10	I	108	7.9	
400-14X2	3D-5015	29.3	51	53	14.3	37.2	13	27	7	IV	130	7.9	31.7

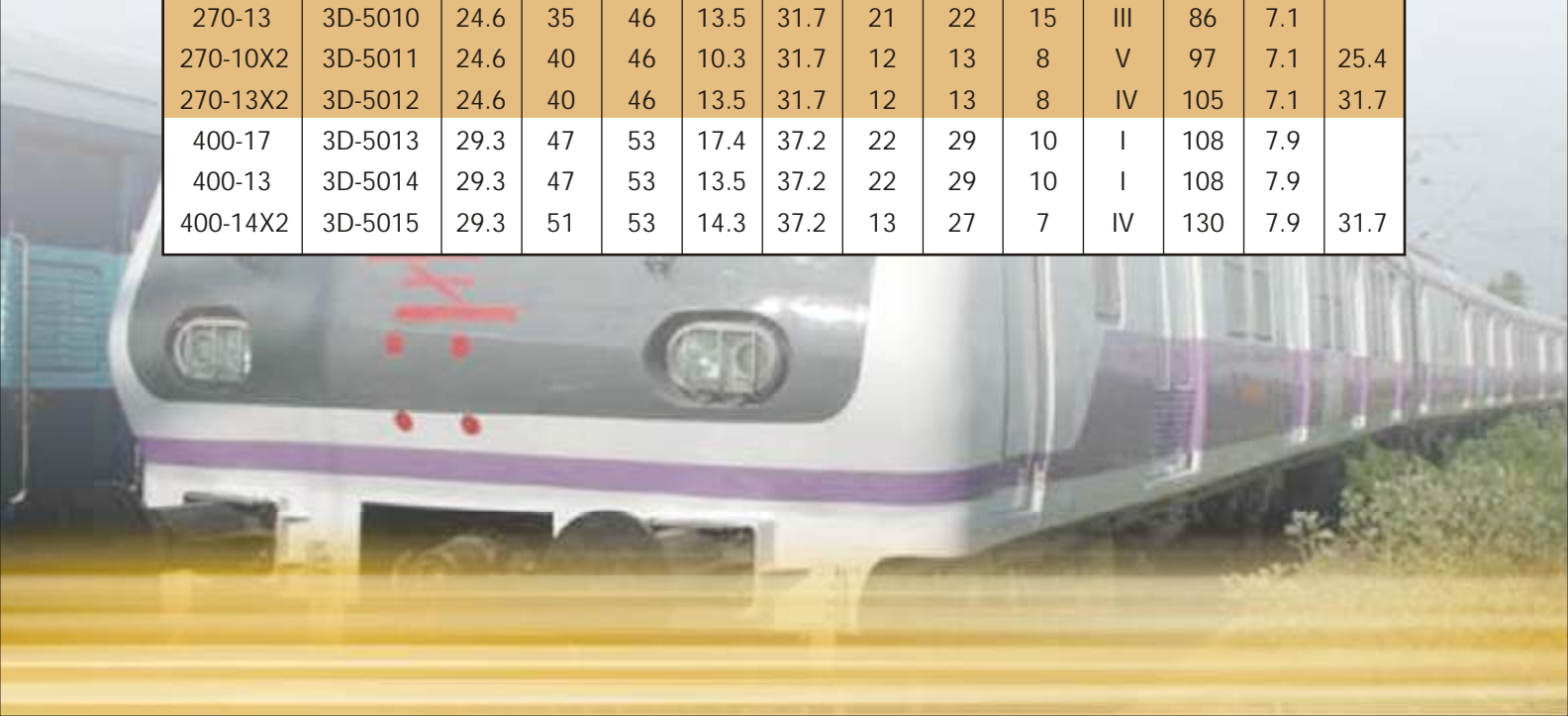





The Crimping people... since 1960

Connectors, Non-tention

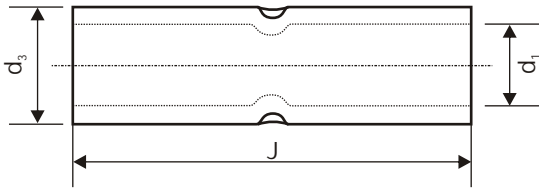
Standard Type With Cable Stopper
Material: E-copper
Surface: Tin Plated



Conductor mm ²	3D CAT NO.	Dimensions In mm			Tools	pcs 
		d ₁	d ₃	J		
1.5	3D-2802	1.8	3.7	12	3D-17, 3D-2	100
2.5	3D-2804	2.4	4.0	15	3D-17, 3D-2	100
4	3D-2806	3.1	4.8	15	3D-17, 3D-2	100
6	3D-2808	3.8	5.5	15	3D-17, 3D-2	100
10	3D-2810	4.5	6.2	20	3D-2, 3D-117,3D-88	100
16	3D-2812	5.4	7.1	20	3D-2, 3D-117,3D-88	50
20	3D-2816	6.0	7.7	20	3D-117, 3D-100,3D-88	50
25	3D-2817	6.8	8.8	32	3D-117, 3D-100,3D-88	50
35	3D-2820	8.2	10.6	36	3D-117, 3D-100,3D-88	50
50	3D-2823	10	12.8	40	3D-117, 3D-100,3D-88	50
70	3D-2826	11.2	14.7	40	3D-117, 3D-100,3D-88	25
95	3D-2828	13.5	17.4	45	3D-117, 3D-100,3D-88	25
120	3D-2830	15.0	19.4	45	3D-117, 3D-100,3D-88	25
150	3D-2833	16.5	21.2	55	3D-117, 3D-100,3D-88	25
185	3D-2836	18.5	23.5	65	3D-117, 3D-100	20
240	3D-2838	21.0	26.5	80	3D-117, 3D-100	10
300	3D-2841	23.5	30.0	85	3D-117, 3D-100	5
400	3D-2843	26.8	34.8	91	3D-117, 3D-100	5
500	3D-2844	30.0	39.0	100	3D-120	5
630	3D-2846	35.0	45.0	112	3D-120	5
800	3D-2847	39.0	50.6	150	3D-120	10
1000	3D-2848	43.0	56.2	170	3D-120	10



The Crimping people... since 1960

Butt Connectors

For Parallel Connection
W/O Cable Stopper
Material: E-copper
Surface: Tin Plated

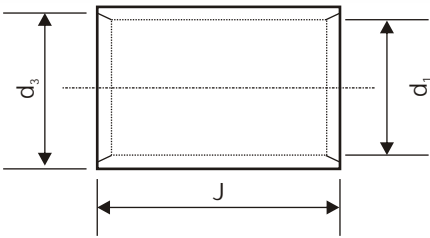

Conductor mm ²	3D CAT NO.	Dimensions In mm			Tools	pcs
		d ₁	d ₃	J		
1.5	3D-2790	1.6	3.2	7	3D-17, 3D-2	100
2.5	3D-2791	2.4	4.0	7	3D-17, 3D-2	100
6	3D-2792	3.5	5.5	7	3D-17, 3D-2	100
10	3D-2793	4.5	6.2	10.5	3D-2, 3D-117,3D-88	100
16	3D-2794	5.4	7.1	11.5	3D-2, 3D-117,3D-88	50
25	3D-2795	6.8	8.8	13	3D-117, 3D-100,3D-88	50
35	3D-2796	8.2	10.6	14	3D-117, 3D-100,3D-88	50
50	3D-2797	10	12.8	16	3D-117, 3D-100,3D-88	50
70	3D-2798	11.2	14.7	18	3D-117, 3D-100,3D-88	25
95	3D-2799	13.5	17.4	19	3D-117, 3D-100,3D-88	25

For Copper Conductors
With & Non Insulating Sleeve
Insulation : Hard PVC
Material: E-copper
Surface: Tin Plated

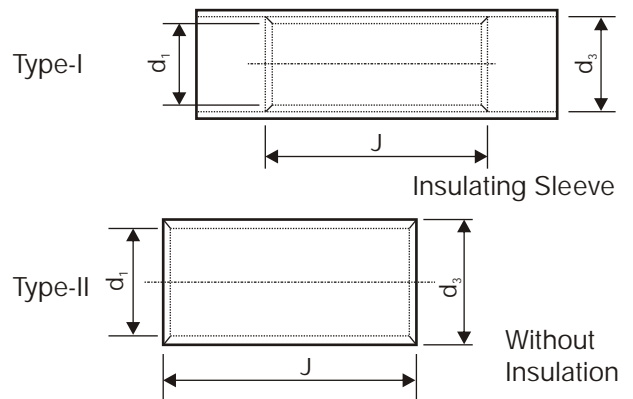

Conductor mm ²		3D CAT NO.	Dimensions In mm			Tools	pcs
			d ₁	d ₃	J		
1.5	TYPE-II	3D-1845	1.6	3.2	15	3D-17 3D-2	100
2.5	TYPE-II	3D-1846	2.4	4.0	15	3D-17 3D-2	50
4	TYPE-II	3D-1847	3.5	5.5	15	3D-17 3D-2	50
1.5	TYPE-I	3D-3762	1.6	3.2	25	3D-41	50
2.5	TYPE-I	3D-3763	2.4	4.0	25	3D-41	50
4	TYPE-I	3D-3764	3.5	5.5	27	3D-41	25



The Crimping people... since 1960

Tubular Cable Lugs Compression Type

Compression Type, Aluminium Terminal ends,
for Crimping to XLPE Conductors,
Material : Aluminium
Surface : Natural

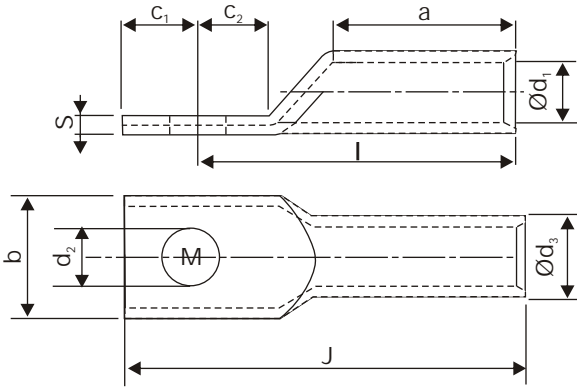

Conductor mm ²	Bolt Ø	3D CAT NO.	Dimensions in mm										Tools	pcs
			Barrel ID	Barrel OD	Stud Size	Palm Width	Palm thick- ness	Barrel Length	Stud Dist- ance From Top	Stud Dist- ance From Barrel	Crre- page Dist- ance	Total Length		
			d_1	d_3	d_2	b	s	a	C_1	C_2	l	J		
16	M 6	3D-4000	5	8.3	6.2	12	1.8	38	9	12	57	66	3D-7 3D-88 3D-100	160
25	M 8	3D-4001	7.2	9.6	8.2	14	2.4	38	9	12	57	66	//	100
35	M 8	3D-4002	8.3	11.1	8.2	16	2.8	47	11	11	65	76	//	80
50	M 10	3D-4003	10.1	13.5	10.2	19.5	3.4	46	11	13	67	78	//	50
70	M 10	3D-4004	11.2	14.5	10.2	20.5	4.3	59	13	13	80	93	//	60
95	M 12	3D-4005	12	16.9	12.7	23.5	4.9	70	14	14	93	107	//	50
120	M 12	3D-4006	13.7	19	12.7	26.5	5.3	70	15	15	96	111	//	40
150	M 12	3D-4007	15.1	21.1	12.7	29.5	6.0	80	17	17	108	125	//	20
	M 16	3D-4008	15.1	21.1	17	29.5	6.0	80	17	17	108	125		20
185	M 12	3D-4009	16.6	23.9	12.7	33	7.3	80	18	18	110	128	3D-7	20
	M 16	3D-4010	16.6	23.9	17	33	7.3	80	18	18	110	128	3D100	20
240	M 12	3D-4012	19.3	27.2	12.7	37.5	7.9	83	22	22	119	141	//	15
	M 16	3D-4013	19.3	27.2	17	37.5	7.9	83	22	22	119	141		15
300	M 12	3D-4015	21.8	30.2	12.7	42	8.4	86	27	27	127	154		12
	M 16	3D-4016	21.8	30.2	17	42	8.4	86	27	27	127	154		12
	M 20	3D-4014	21.8	30.2	20.1	42	8.4	86	27	27	127	154	//	12
400	M 20	3D-4017	25	34.8	20.3	48	9.8	110	30	30	154	184	3D-120	5
500	M 20	3D-4018	28.2	39.1	20.3	54	10.9	122	32	32	170	202	//	5
630	BLK	3D-4019	31.7	44.4		61	12.7	137	34	34	188	222	//	5
800	BLK	3D-4020	35.7	49.5		68	13.8	144	39	39	208	247	//	2
1000	BLK	3D-4021	41	56		77.5	15.0	157	45	45	232	277	//	2



The Crimping people... since 1960

Tubular Cable Lugs Compression Type

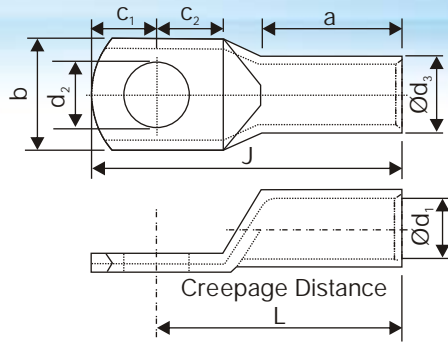

Aluminum Tubular Terminal Ends
for Crimping to Aluminum Conductors
Material: Aluminum
Surface: Natural



Conductor mm ²	Bolt Ø	3D CAT NO.	Dimensions in mm									Tools	pcs
			Barrel ID	Barrel OD	Stud Size	Palm Width	Barrel Length	Stud Distance	Stud Distance From Top	Creepage Dist-From Barrel	Total Length		
			d_1	d_3	d_2	b	a	C_1	C_2	l	J		
2.5	M 3	3D-2535	2.6	5.5	3.2	6.7	7	4	4	14	18	3D-17	100
4	M 4	3D-2536	2.9	5.5	4.2	7.2	7	4	4	14	18	3D-17	100
	M 5	3D-2537	2.9	5.5	5.2	12.0	7	5	5	16	21	3D-2	
6	M 6	3D-2538	3.5	5.5	6.4	12.0	7	6	6	17	23	3D-17	100
10	M 6	3D-2539	4.4	7.2	6.4	9.7	9	8	9	22	30	3D-7	100
	M 8	3D-2540	4.4	7.2	8.2	15.0	9	8	9	22	30	3D-2	
16	M 6	3D-2541	5.4	8.3	6.4	11.4	13	9	11	28	37	3D-7	50
	M 8	3D-2542	5.4	8.3	8.2	11.7	13	9	11	28	37	3D-88	
	M 10	3D-2543	5.4	8.3	10.2	18.0	13	9	11	29	38		
25	M 6	3D-2544	7.0	9.7	6.4	13.7	16	10	11	34	44	3D-7	50
	M 8	3D-2545	7.0	9.7	8.2	13.7	16	10	11	34	44	3D-124	
	M 10	3D-2546	7.0	9.7	10.2	14.0	16	10	11	34	44	3D-95H	
	M 12	3D-2547	7.0	9.7	12.7	20.0	16	12	12	35	47		
35	M 6	3D-2548	8.0	10.8	6.4	15.4	18	11	11	35	46	3D-7	50
	M 8	3D-2549	8.0	10.8	8.2	15.4	18	11	11	35	46	3D-124	
	M 10	3D-2550	8.0	10.8	10.2	15.7	18	11	11	35	46	3D-88	
50	M 8	3D-2551	9.3	13.0	8.2	18.3	22	11	13	43	54	3D-7	50
	M 10	3D-2552	9.3	13.0	10.2	18.3	22	11	13	43	54	3D-124	
	M 12	3D-2553	9.3	13.0	12.7	18.5	22	12	13	42	54		
70	M 8	3D-2554	11.3	15.5	8.2	21.8	26	13	13	47	60	3D-7	25
	M 10	3D-2555	11.3	15.5	10.2	21.8	26	13	13	47	60	3D-124	
	M 12	3D-2556	11.3	15.5	12.7	21.8	26	13	13	47	60		
95	M 10	3D-2557	13.2	17.4	10.2	24.8	28	14	14	50	64	3D-7	25
	M 12	3D-2558	13.2	17.4	12.7	24.8	28	14	14	50	64	3D-124	
	M 16	3D-2559	13.2	17.4	16.2	24.8	28	15	15	51	66		
120	M 10	3D-2560	14.7	19.6	10.2	28.0	32	15	15	58	73	3D-7	25
	M 12	3D-2561	14.7	19.6	12.7	28.0	32	15	15	58	73	3D-124	
	M 16	3D-2562	14.7	19.6	16.2	28.0	32	15	15	58	73	3D-88	
150	M 10	3D-2563	16.4	21.5	10.2	30.8	34	17	17	62	79	3D-7	25
	M 12	3D-2564	16.4	21.5	12.7	30.8	34	17	17	62	79	3D-124	
	M 16	3D-2565	16.4	21.5	16.2	30.8	34	17	17	62	79		
185	M 10	3D-2566	18.4	24.0	10.2	34.5	36	18	18	66	84	3D-7	20
	M 12	3D-2567	18.4	24.0	12.7	34.5	36	18	18	66	84	3D-124	
	M 16	3D-2568	18.4	24.0	16.2	34.5	36	18	18	66	84	3D-95H	
240	M 12	3D-2569	21.0	28.0	12.7	40.0	44	22	22	80	102	3D-7	10
	M 16	3D-2570	21.0	28.0	16.2	40.0	44	22	22	80	102	3D-124	
300	M 16	3D-2571	23.8	31.0	16.2	45.0	47	27	27	88	115	3D-7	5
	M 20	3D-2572	23.8	31.0	20.3	45.0	47	27	27	88	115	3D-124	
400	M 20	3D-2573	26.8	35.5	20.3	50.8	56	30	31	100	130	3D-7	5
500	M 20	3D-2574	29.9	41.0	20.3	57.8	60	32	33	108	140	3D-150	5
630	M 20	3D-2575	34.9	46.0	20.3	65.8	59	34	35	120	154	3D-150	5
800	BLK	3D-2576	39.0	51.0		73.3	77	39	39	141	180	3D-150	10
1000	BLK	3D-2577	43.0	57.0		81.5	100	45	45	175	220	3D-150	10

Note : ISI Licence is given for catalogue numbers 3D-2541 Through 3D-2573 (16 mm² to 400 mm²)
16-10 3D -2543 & 25-12 3D. 2547 W/O ISI Mark



The Crimping people... since 1960

Tubular Cable Lugs Compression Type

Aluminum Tubular In-Line Connectors
for Crimping to Aluminum Conductors
Material: Aluminum
Surface: Natural

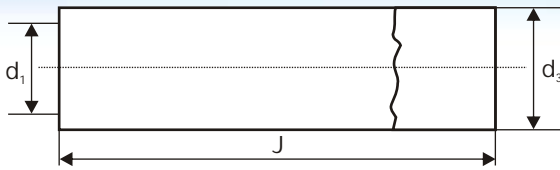

Conductor mm ²	3D CAT NO.	Dimensions In mm			Tools	pcs
		d_1	d_3	J		
2.5	3D-2578	2.6	5.5	16	3D-17, 3D-2, 3D-88	100
4	3D-2579	2.9	5.5	16	3D-17, 3D-2, 3D-88	100
6	3D-2580	3.5	5.5	20	3D-17, 3D-2, 3D-88	100
10	3D-2581	4.4	7.2	20	3D-2, 3D-7, 3D-88	100
16	3D-2582	5.4	8.3	26	3D-2, 3D-7, 3D-88	50
25	3D-2583	7.0	9.7	34	3D-7, 3D-124, 3D-88	50
35	3D-2584	8.0	10.8	39	3D-7, 3D-124, 3D-95H	50
50	3D-2585	9.3	13.0	44	3D-7, 3D-124, 3D-88	50
70	3D-2586	11.3	15.5	53	3D-7, 3D-124, 3D-88	25
95	3D-2587	13.2	17.4	58	3D-7, 3D-124, 3D-88	25
120	3D-2588	14.7	19.6	63	3D-7, 3D-124, 3D-88	25
150	3D-2589	16.4	21.5	67	3D-7, 3D-124	25
185	3D-2590	18.4	24.0	72	3D-7, 3D-124	20
240	3D-2591	21.0	28.0	86	3D-7, 3D-124	10
300	3D-2592	23.8	31.0	96	3D-7, 3D-124	5
400	3D-2593	26.8	35.5	110	3D-7, 3D-124	5
500	3D-2594	29.9	41.0	111	3D-150	5
630	3D-2595	34.9	46.0	134	3D-150	5
800	3D-2596	39.0	51.0	153	3D-150	10
1000	3D-2597	43.0	57.0	201	3D-150	10

Note : All Aluminium Terminals and Connectors can be tin plated upon request.

"3D-112" Corrosion Inhibiting Compound

(Based on Recommendations of Aluminium Federation of U.K. / British Standards Institutions spec. G-184/188)

Recommended Practice for Resistance to Corrosion

Whilst aluminium withstands weathering without protection during many years of service, the use of a corrosion inhibiting compound is recommended where conditions are particularly aggressive, such as chemical or salt-laden atmospheres, or where inspection and cleaning are likely to be irregular.

Such an inhibitor must:

- not affect electrical properties of the compression joint.
- be non-corrosive to aluminium, copper, steel, tin, zinc and combinations of these:
- not deteriorate on exposure to atmosphere at conductor operating temperatures:
- have good sealing properties against moisture and contaminating substances in the atmosphere.
- have a high temperature drop point:

This Corrosion Inhibiting Compound "3D-112" made as per British Standards Institution specification, is recommended for application over the prepared end of the conductor and inside the ferrule/terminal end, before crimping.





The Crimping people... since 1960

End-Sleeves

Dimensions DIN 46228, Part 4

Material: Copper

Surface: Tin Plated

Insulated: Free of Halide

Synthetic Material: Polypropylene

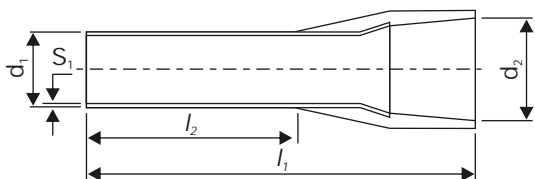

Conductor mm ²	3D CAT NO.	Dimensions in mm					Colour Group II	Tools	pcs 
		d_1	d_2	S_1	l_1	l_2			
0.5	3D-8004 H	1.0	2.6	0.15	12.0	6.0	WHITE	3D-48	1000
	3D-8147 H				14.0	8.0		3D-52	
	3D-8035 H				16.0	10.0			
0.75	3D-8005 H	1.2	2.8	0.15	12.3	6.0	GREY	3D-48	1000
	3D-8149 H				14.3	8.0		3D-52	
	3D-8036 H				16.3	10.0			
1	3D-8006 H	1.4	3.0	0.15	12.3	6.0	RED	3D-48	1000
	3D-8154 H				14.3	8.0		3D-52	
	3D-8007 H				16.3	10.0			
1.5	3D-8159 H	1.7	3.5	0.15	14.3	8.0	BLACK	3D-48	1000
	3D-8009 H				16.3	10.0		3D-52	
	3D-8038 H				24.3	18.0			
2.5	3D-8162 H	2.3	4.0	0.15	15.4	8.0	BLUE	3D-48	1000
	3D-8011 H				19.4	12.0		3D-52	
4	3D-8012 H	2.8	4.5	0.2	17.4	10.0	GREY	3D-48	1000
	3D-8013 H				19.4	12.0		3D-52	
6	3D-8015 H	3.5	6.0	0.2	20.5	12.0	YELLOW	3D-48	100
	3D-8043 H				26.5	18.0		3D-52	
10	3D-8017 H	4.5	7.5	0.2	22.8	12.0	RED	3D-48	100
16	3D-8020 H	5.8	8.7	0.2	22.0	12.0	BLUE	3D-48	100
	3D-8022 H				28.0	18.0		3D-53	
25	3D-8046 H	7.3	11.0	0.2	28.0	16.0	YELLOW	3D-110	50
	3D-8047 H				30.0	18.0			
35	3D-8050 H	8.3	12.5	0.2	30.0	16.0	RED	3D-110	50
	3D-8051 H				39.0	25.0			
50	3D-8053 H	10.3	15.0	0.3	36.0	20.0	BLUE	3D-110	50
	3D-8054 H				41.0	25.0			



The Crimping people... since 1960

Twin - Cable Endsleeves

Standard Type, With Insulating Sleeve
 Material: E-Copper + PVC
 Surface: Tin Plated

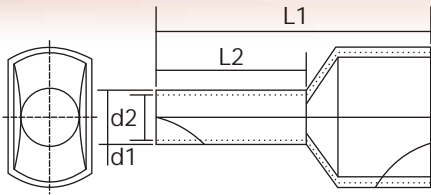

Conductor mm ²	3D CAT NO.	Dimensions in mm				Colour System	Tools	Pcs.
		d1	d2	L1	L2			
0.5-8*2	3D-7000	1.8	1.5	14.5	8	White	3D-48, 3D-48	1000
0.75-8*2	3D-7001	2.1	1.8	14.5	8	Grey	3D-48, 3D-52	1000
0.75-10*2	3D-7002	2.1	1.8	16.7	10		1000	
1.0-8*2	3D-7003	2.3	2	15.1	8	Red	3D-48, 3D-52	1000
1.0-10*2	3D-7004	2.3	2	17.1	10	Black	3D-48, 3D-52	1000
1.5-8*2	3D-7005	2.6	2.3	15.5	8		1000	
1.5-12*2	3D-7006	2.6	2.3	19.5	12	Blue	3D-48, 3D-52	1000
2.5-10*2	3D-7007	3.3	2.8	18.5	10		1000	
2.5-13*2	3D-7008	3.3	2.9	21.5	13	Grey	3D-48, 3D-52	1000
4.0-12*2	3D-7009	4.2	3.8	23.1	12		1000	
6.0-14*2	3D-7010	5.3	4.9	26.1	14	Yellow	3D-48, 3D-52	1000
10-14*2	3D-7011	6.9	6.5	26.6	14	Red	3D-48, 3D-52	1000
16-14*2	3D-7012	8.7	8.3	31.3	14	Blue	3D-48, 3D-52	1000

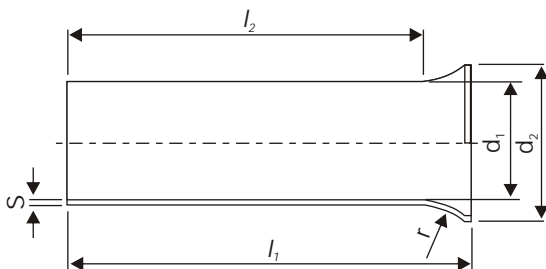

End-Sleeves

Dimensions DIN 46228, Part 1
 Material: Copper
 Surface: Tin Plated



Conductor mm ²	3D CAT NO.	Dimensions In mm					Tools	pcs
		d ₁	d ₂	S	l ₁	l ₂		
0.5	3D-8004	1.0	1.7	0.15	6	5.3	3D-48	1000
	3D-8035	1.0	1.7	0.15	10	9.3	3D-52	
0.75	3D-8005	1.2	1.9	0.15	6	5.3	3D-48	1000
	3D-8036	1.2	1.9	0.15	10	9.3	3D-52	
1	3D-8006	1.4	2.2	0.15	6	5.3	3D-48	1000
	3D-8007	1.4	2.2	0.15	10	9.3	3D-52	
1.5	3D-8008	1.7	2.5	0.15	7	6.0	3D-48	1000
	3D-8009	1.7	2.5	0.15	10	9.0	3D-52	
	3D-8037	1.7	2.5	0.15	12	11.0		
	3D-8038	1.7	2.5	0.15	18	17.0		



The Crimping people... since 1960

End-Sleeves

Dimensions DIN 46228, Part 1
Material: Copper
Surface: In Plated

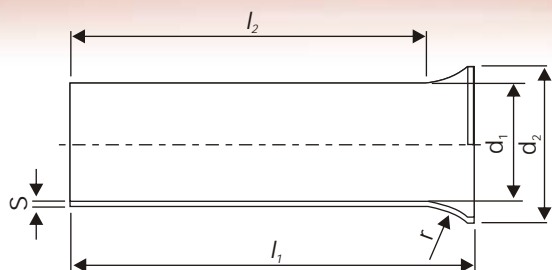

Conductor mm ²	3D CAT NO.	Dimensions In mm					Tools	pcs
		d ₁	d ₂	S	l ₁	l ₂		
2.5	3D-8010	2.3	3.3	0.15	7	6.0	3D-48	1000
	3D-8039	2.3	3.3	0.15	10	9.0	3D-52	1000
	3D-8011	2.3	3.3	0.15	12	11.0		1000
	3D-8040	2.3	3.3	0.15	18	17.0		1000
4	3D-8012	2.8	3.9	0.2	9	8.0	3D-48	1000
	3D-8013	2.8	3.9	0.2	12	11.0	3D-52	1000
	3D-8041	2.8	3.9	0.2	15	14.0		1000
	3D-8042	2.8	3.9	0.2	18	17.0		1000
6	3D-8014	3.5	4.7	0.2	10	9.0	3D-48	250
	3D-8015	3.5	4.7	0.2	12	11.0	3D-52	250
	3D-8016	3.5	4.7	0.2	15	14.0		250
	3D-8043	3.5	4.7	0.2	18	17.0		250
10	3D-8017	4.5	5.8	0.2	12	10.8	3D-48	250
	3D-8018	4.5	5.8	0.2	15	13.8	3D-53	250
	3D-8019	4.5	5.8	0.2	18	16.8		250
16	3D-8020	5.8	7.2	0.2	12	10.5	3D-48	250
	3D-8021	5.8	7.2	0.2	15	13.5	3D-53	250
	3D-8022	5.8	7.2	0.2	18	16.5		250
	3D-8044	5.8	7.2	0.2	25	23.5		
	3D-8045	5.8	7.2	0.2	32	30.5		
25	3D-8046	7.3	9.1	0.2	15	13.0	3D-110	250
	3D-8047	7.3	9.1	0.2	18	16.0		250
	3D-8048	7.3	9.1	0.2	25	23.0		100
	3D-8049	7.3	9.1	0.2	32	30.0		
35	3D-8050	8.3	10.2	0.2	18	16.0		100
	3D-8051	8.3	10.2	0.2	25	23.0		100
	3D-8052	8.3	10.2	0.2	32	30.0		
50	3D-8053	10.3	12.7	0.3	18	15.0	3D-110	
	3D-8054	10.3	12.7	0.3	25	22.0		
	3D-8055	10.3	12.7	0.3	32	29.0		
70	3D-8056	13.5	15.8	0.4	25	22.0		100
	3D-8057	13.5	15.8	0.4	32	29.0		
95	3D-8058	14.8	17.3	0.4	25	22.0	3D-110	
	3D-8059	14.8	17.3	0.4	32	29.0		
120	3D-8060	16.7	20.2	0.3	32	29.0		50
	3D-8061	16.7	20.2	0.3	40	37.0		
150	3D-8062	19.6	23.0	0.5	32	29.0	3D-110	
	3D-8063	19.6	23.0	0.5	40	37.0		
185	3D-8064	20.2	23.9	0.6	32	29.0	3D-110	
	3D-8065	20.2	23.9	0.6	40	37.0		25



The Crimping people... since 1960

Sheet Metal Lugs, Ring Type

Standard Type
 Brazed Seam
 Material: E-Copper
 Surface: Tin Plated

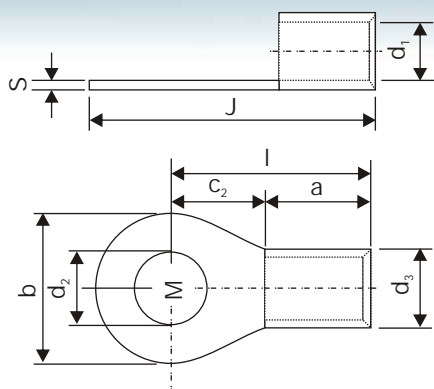

Conductor mm ²	Bolt Ø	3D CAT NO.	Dimensions In mm										Tools	pcs
			d ₁	d ₃	d ₂	b	s	a	C ₂	l	J			
0.5 To 1.5 mm ²	M 2	3D-1263	1.6	3.2	2.2	6	0.8	5	6	11	14	3D-2 3D-17	150	
	M 2.5	3D-1242	1.6	3.2	2.6	6	0.8	5	6	11	14			
	M 3	3D-1247	1.6	3.2	3.2	6	0.8	5	6	11	14			
	M 3	3D-1260	1.6	3.2	3.2	6.8	0.8	5	4.6	9.6	13			
	M 3	3D-1265	1.6	3.2	3.2	8	0.8	5	7	12	16			
	M 3.5	3D-1269	1.6	3.2	3.7	6	0.8	5	6	11	14			
	M 3.5	3D-1257	1.6	3.2	3.7	6.8	0.8	5	4.6	9.6	13			
	M 4	3D-1241	1.6	3.2	4.2	6	0.8	5	6	11	14			
	M 4	3D-1258	1.6	3.2	4.2	6.8	0.8	5	4.6	9.6	13			
	M 4	3D-1246	1.6	3.2	4.2	8	0.8	5	7	12	16			
	M 4	3D-1261	1.6	3.2	4.2	7	0.8	5	6	11	14.5			
	M 4	3D-1266	1.6	3.2	4.2	10	0.8	5	8	13	18			
	M 5	3D-1262	1.6	3.2	5.2	8	0.8	5	7	12	16			
	M 5	3D-1267	1.6	3.2	5.2	10	0.8	5	8	13	18			
	2.5 ² mm	M 6	3D-1224	1.6	3.2	6.4	10	0.8	5	8	13	18		3D-2 3D-17
M 6		3D-1268	1.6	3.2	6.4	12	0.8	5	7	12	18			
M 3		3D-1308	2.3	3.9	3.2	6.5	0.8	5	4.5	9.5	12.7			
M 3.5		3D-1292	2.3	3.9	3.7	6.5	0.8	5	4.5	9.5	12.7			
M 3.5		3D-1309	2.3	3.9	3.7	8	0.8	5	7	12	16			
M 4		3D-1296	2.3	3.9	4.2	8	0.8	5	7	12	16			
M 5		3D-1304	2.3	3.9	5.2	8	0.8	5	7	12	16			
M 5		3D-1310	2.3	3.9	5.2	10	0.8	5	8	13	18			
M 5		3D-1313	2.3	3.9	5.2	12	0.8	5	11	16	22			
M 6		3D-1342	2.3	3.9	6.4	10	0.8	5	8	13	18			
M 6		3D-1305	2.3	3.9	6.4	12	0.8	5	11	16	22			
M 6		3D-1314	2.3	3.9	6.4	16	0.8	5	12	17	25			
M 8		3D-1307	2.3	3.9	8.2	12	0.8	5	11	16	22			
M 8	3D-1311	2.3	3.9	8.2	16	0.8	5	12	17	25				
M 10	3D-1287	2.3	3.9	10.2	16	0.8	5	12	17	25				
M 10	3D-1524	2.3	3.9	10.2	18	0.8	5	15	20	29				
M 12	3D-1438	2.3	3.9	12.7	18	0.8	5	15	20	29				



The Crimping people... since 1960

Sheet Metal Lugs, Ring Type

Standard Type
 Brazed Seam
 Material: E-Copper
 Surface: Tin Plated

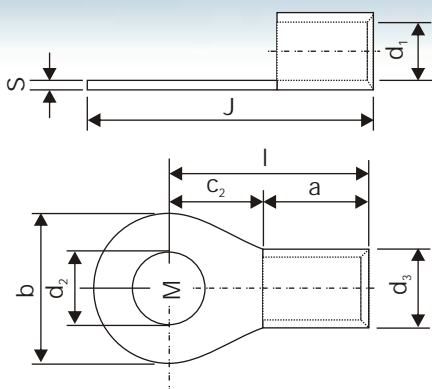

Conductor mm ²	Bolt Ø	3D CAT NO.	Dimensions in mm									Tools	pcs
			d ₁	d ₃	d ₂	b	s	a	C ₂	l	J		
4mm ² To 6mm ²	M 4	3D-1432	3.5	5.5	4.2	8	1	6	7	13	17	3D-17 3D-2	100
	M 4	3D-1435	3.5	5.5	4.2	10	1	6	8	14	19		
	M 5	3D-1431	3.5	5.5	5.2	8	1	6	7	13	17		
	M 5	3D-1408	3.5	5.5	5.2	10	1	6	8	14	19		
	M 5	3D-1433	3.5	5.5	5.2	8	1	6	12.8	18.8	22.8		
	M 5	3D-1405	3.5	5.5	5.2	12	1	6	8	14	20		
	M 5	3D-1404	3.5	5.5	5.2	12	1	6	10	16	22		
	M 6	3D-1415	3.5	5.5	6.4	12	1	6	8	14	20		
	M 6	3D-1417	3.5	5.5	6.4	12	1	6	10	16	22		
	M 6	3D-1406	3.5	5.5	6.4	14	1	6	12.5	18.5	25.5		
	M 8	3D-1416	3.5	5.5	8.2	12	1	6	8	14	20		
	M 8	3D-1421	3.5	5.5	8.2	14	1	6	12.5	18.5	25.5		
	M 8	3D-1407	3.5	5.5	8.2	16	1	6	16	22	30		
	M 8	3D-1429	3.5	5.5	8.2	18	1	6	15	21	30		
	M 9	3D-1410	3.5	5.5	9.7	14	1	6	12.5	18.5	25.5		
	M 10	3D-1427	3.5	5.5	10.2	16	1	6	16	22	30		
M 10	3D-1428	3.5	5.5	10.2	18	1	6	15	21	30			
M 12	3D-1430	3.5	5.5	12.7	18	1	6	15	21	30			
10mm ²	M 4	3D-1463	4.3	6.3	4.2	10	1	8	9	17	22	3D-2	100
	M 4	3D-1464	4.3	6.3	4.2	10	1	8	7	15	20		
	M 5	3D-1459	4.3	6.3	5.2	10	1	8	9	17	22		
	M 5	3D-1460	4.3	6.3	5.2	10	1	8	7	15	20		
	M 6	3D-1465	4.3	6.3	6.4	12	1	8	9	17	23		
	M 8	3D-1466	4.3	6.3	8.2	16	1	8	11	19	27		
	M 8	3D-1467	4.3	6.3	8.2	18	1	8	13	21	30		
	M 10	3D-1461	4.3	6.3	10.2	18	1	8	13	21	30		
	M 10	3D-1468	4.3	6.3	10.2	22	1	8	15	23	34		
	M 12	3D-1462	4.3	6.3	12.7	22	1	8	15	23	34		



The Crimping people... since 1960

Sheet Metal Lugs, Ring Type

Standard Type
 Brazed Seam
 Material: E-Copper
 Surface: Tin Plated

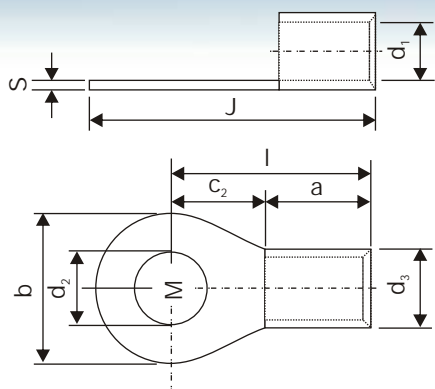

Conductor mm ²	Bolt Ø	3D CAT NO.	Dimensions in mm									Tools	pcs
			d ₁	d ₃	d ₂	b	s	a	C ₂	l	J		
16mm ²	M 5	3D-1516	5.6	8	5.2	10	1.2	10	9	19	24	3D-2 3D-109	50
	M 5	3D-1517	5.6	8	5.2	12	1.2	10	10	20	26		
	M 6	3D-1511	5.6	8	6.4	12	1.2	10	10	20	26		
	M 6	3D-1518	5.6	8	6.4	16	1.2	10	12	22	30		
	M 8	3D-1512	5.6	8	8.2	16	1.2	10	12	22	30		
	M 8	3D-1519	5.6	8	8.2	18	1.2	10	14	24	33		
	M 9	3D-1513	5.6	8	9.7	16	1.2	10	12	22	30		
	M 10	3D-1514	5.6	8	10.2	18	1.2	10	14	24	33		
	M 10	3D-1520	5.6	8	10.2	22	1.2	10	14	24	35		
	M 12	3D-1515	5.6	8	12.7	22	1.2	10	14	24	35		
25mm ²	M 6	3D-1561	7.5	11.1	6.4	12	1.8	11	14	25	31	3D-109	50
	M 6	3D-1557	7.5	11.1	6.4	16	1.8	11	11	22	30		
	M 6	3D-1558	7.5	11.1	6.4	16	1.8	11	14	25	33		
	M 8	3D-1556	7.5	11.1	8.2	12	1.8	11	14	25	31		
	M 8	3D-1552	7.5	11.1	8.2	16	1.8	11	11	22	30		
	M 8	3D-1554	7.5	11.1	8.2	16	1.8	11	14	25	33		
	M 10	3D-1553	7.5	11.1	10.2	16	1.8	11	11	22	30		
	M 10	3D-1559	7.5	11.1	10.2	18	1.8	11	14	25	34		
	M 10	3D-1560	7.5	11.1	10.2	22	1.8	11	20	31	42		
	M 12	3D-1555	7.5	11.1	12.7	22	1.8	11	20	31	42		
35mm ²	M 6	3D-1584	9	12.6	6.4	16	1.8	12	11	23	31	3D-109	50
	M 8	3D-1581	9	12.6	8.2	16	1.8	12	11	23	31		
	M 8	3D-1585	9	12.6	8.2	18	1.8	12	15	27	36		
	M 10	3D-1582	9	12.6	10.8	18	1.8	12	15	27	36		
	M 10	3D-1586	9	12.6	10.2	22	1.8	12	19	31	42		
	M 12	3D-1583	9	12.6	12.7	22	1.8	12	19	31	42		



The Crimping people... since 1960

Sheet Metal Lugs, Ring Type

Standard Type
 Brazed Seam
 Material: E-Copper
 Surface: Tin Plated

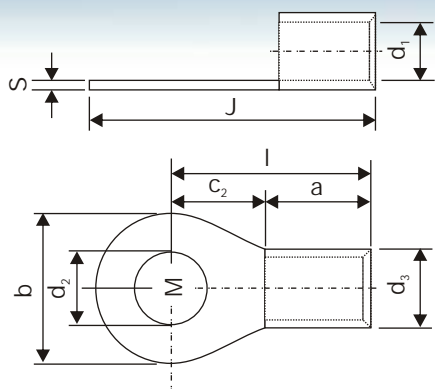

Conductor mm ²	Bolt Ø	3D CAT NO.	Dimensions in mm									Tools	pcs
			d ₁	d ₃	d ₂	b	s	a	C ₂	l	J		
50mm ²	M 8	3D-1609	10.5	14.1	8.2	18	1.8	16	18	34	43	3D-109	50
	M 10	3D-1607	10.5	14.1	10.2	18	1.8	16	18	34	43		
	M 10	3D-1610	10.5	14.1	10.2	22	1.8	16	16	32	43		
	M 10	3D-1611	10.5	14.1	10.2	24	1.8	16	20	36	48		
	M 12	3D-1608	10.5	14.1	12.7	24	1.8	16	20	36	48		
	M 16	3D-1612	10.5	14.1	16.2	32	1.8	16	22	38	54		
70mm ²	M 10	3D-1637	12	16	10.4	22	2	18	18	36	47	3D-109	25
	M 12	3D-1636	12	16	12.7	22	2	18	18	36	47		
	M 12	3D-1638	12	16	12.7	24	2	18	18	36	48		
	M 16	3D-1639	12	16	16.2	28	2	18	22	40	54		
95mm ²	M 10	3D-1651	13.5	18.1	10.2	22	2.3	20	15	35	46	3D-109	25
	M 10	3D-1652	13.5	18.1	10.2	24	2.3	18	20	38	50		
	M 12	3D-1650	13.5	18.1	12.7	24	2.3	20	18	38	50		
	M 16	3D-1653	13.5	18.1	16.2	28	2.3	20	24	44	58		
120mm ²	M 12	3D-1658	15	20.2	12.7	26	2.6	22	17	39	52	3D-109	25
	M 16	3D-1659	15	20.2	16.2	32	2.6	22	26	48	64		
	M 20	3D-1660	15	20.2	20.3	40	2.6	22	30	52	72		
150mm ²	M 12	3D-1668	16.5	23.7	12.7	34	3.6	24	25	49	66	3D-109	25
	M 16	3D-1666	16.5	23.7	16.2	34	3.6	24	25	49	66		
	M 16	3D-1669	16.5	23.7	16.2	40	3.6	24	30	54	74		
	M 20	3D-1667	16.5	23.7	20.3	40	3.6	24	30	54	74		



The Crimping people... since 1960

Sheet Metal Lugs, Ring Type

Standard Type, With Insulating Sleeve
 Material: E-Copper With PVC Sleeve
 Surface: Tin Plated

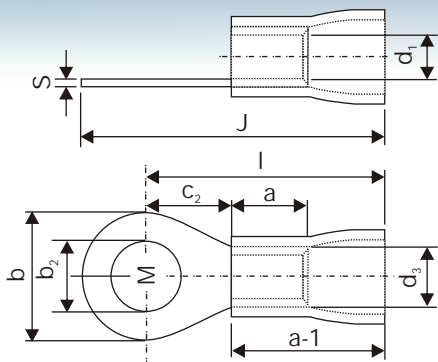

Conductor Mm ²	Bolt Ø	3D CAT NO.	Dimensions in mm									Tools	pcs
			d ₁	d ₃	d ₂	b	s	a	C ₂	l	J		
0.5 To 1.5mm ²	M 2	3D-3076	1.6	3.2	2.2	6	0.8	5	4	16	19	3D-41	100
	M 2.5	3D-3077	1.6	3.2	2.6	6	0.8	5	4	16	19		
	M 3	3D-3078	1.6	3.2	3.2	6	0.8	5	4	16	19		
	M 3	3D-3081	1.6	3.2	3.2	6.8	0.8	5	3.6	14.6	18		
	M 3	3D-3084	1.6	3.2	3.2	8	0.8	5	5	17	21		
	M 3.5	3D-3079	1.6	3.2	3.7	6	0.8	5	4	16	19		
	M 3.5	3D-3082	1.6	3.2	3.7	6.8	0.8	5	3.8	14.6	18		
	M 4	3D-3080	1.6	3.2	4.2	6	0.8	5	4	16	19		
	M 4	3D-3083	1.6	3.2	4.2	6.8	0.8	5	3.6	14.6	18		
	M 4	3D-3085	1.6	3.2	4.2	8	0.8	5	5	17	21		
	M 4	3D-3087	1.6	3.2	4.2	7.2	0.8	5	5	16	19.5		
	M 4	3D-3088	1.6	3.2	4.2	10	0.8	5	6	18	23		
	M 5	3D-3086	1.6	3.2	5.2	8	0.8	5	5	17	21		
	M 5	3D-3074	1.6	3.2	5.2	10	0.8	5	6	18	23		
M 6	3D-3089	1.6	3.2	6.4	10	0.8	5	6	18	23			
M 6	3D-3090	1.6	3.2	6.4	12	0.8	5	6	17	23			
2.5mm ²	M 3	3D-3126	2.3	3.9	3.2	6.5	0.8	5	3.5	14.5	17.7	3D-41	100
	M 3.5	3D-3127	2.3	3.9	3.7	6.5	0.8	5	3.5	14.5	17.7		
	M 3.5	3D-3128	2.3	3.9	3.7	8	0.8	5	5	17	21		
	M 4	3D-3129	2.3	3.9	4.2	8	0.8	5	5	17	21		
	M 5	3D-3130	2.3	3.9	5.2	8	0.8	5	5	17	21		
	M 5	3D-3131	2.3	3.9	5.2	10	0.8	5	7	18	23		
	M 5	3D-3133	2.3	3.9	5.2	12	0.8	5	9	21	27		
	M 6	3D-3132	2.3	3.9	6.4	10	0.8	5	7	18	23		
	M 6	3D-3134	2.3	3.9	6.4	12	0.8	5	9	21	27		
	M 6	3D-3136	2.3	3.9	6.4	16	0.8	5	10	22	30		
	M 8	3D-3135	2.3	3.9	8.2	12	0.8	5	9	21	27		
	M 8	3D-3137	2.3	3.9	8.2	16	0.8	5	10	22	30		
	M 10	3D-3138	2.3	3.9	10.2	16	0.8	5	10	22	30		
	M 10	3D-3139	2.3	3.9	10.2	18	0.8	5	14	25	34		
M 12	3D-3140	2.3	3.9	12.7	18	0.8	5	14	25	34			
4 - 6mm ²	M 4	3D-3196	3.5	5.5	4.2	8	1	6	5	21	25	3D-41	100
	M 5	3D-3197	3.5	5.5	5.2	8	1	6	5	21	25		



The Crimping people... since 1960

Sheet Metal Lugs, Ring Type

Standard Type, With Insulating Sleeve
 Material: E-Copper + PVC
 Surface: Tin Plated

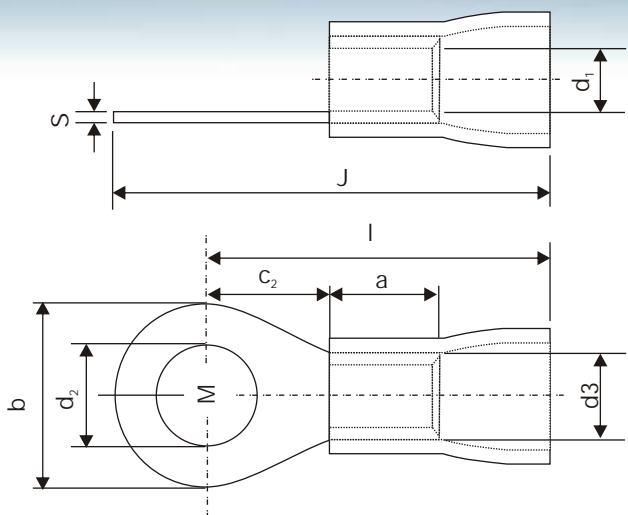

Conductor mm ²	Bolt Ø	3D CAT NO.	Dimensions in mm									Tools	pcs
			d ₁	b	d ₂	s	a	d ₃	C ₂	I	J		
4 - 6mm ²	M 4	3D-3198	3.5	10	4.3	1	6	5.5	5	22	27	3D-41	100
	M 5	3D-3199	3.5	10	5.2	1	6	5.5	5	22	27		
	M 5	3D-3200	3.5	8	5.2	1	6	5.5	9.8	26	30		
	M 5	3D-3201	3.5	12	5.2	1	6	5.5	6	22	28		
	M 5	3D-3204	3.5	12	5.2	1	6	5.5	7	24	30		
	M 6	3D-3202	3.5	12	6.4	1	6	5.5	6	22	28		
	M 6	3D-3205	3.5	12	6.4	1	6	5.5	7	24	30		
	M 6	3D-3206	3.5	14	6.4	1	6	5.5	10.5	26.5	33.5		
	M 8	3D-3203	3.5	12	8.2	1	6	5.5	6	22	28		
	M 8	3D-3207	3.5	14	8.2	1	6	5.5	10.5	26.5	33.5		
	M 8	3D-3209	3.5	16	8.2	1	6	5.5	13	30	38		
	M 8	3D-3211	3.5	18	8.2	1	6	5.5	12	29	38		
	M 9	3D-3208	3.5	14	9.7	1	6	5.5	10.5	26.5	33.5		
	M 10	3D-3210	3.5	16	10.2	1	6	5.5	13	30	38		
	M 10	3D-3212	3.5	18	10.2	1	6	5.5	12	29	38		
M 12	3D-3213	3.5	18	12.7	1	6	5.5	12	29	38			



The Crimping people... since 1960

Sheet Metal Lugs, Ring Type

Double Grip With Insulating Sleeve
Material: E-Copper + PVC
Surface: Tin Plated

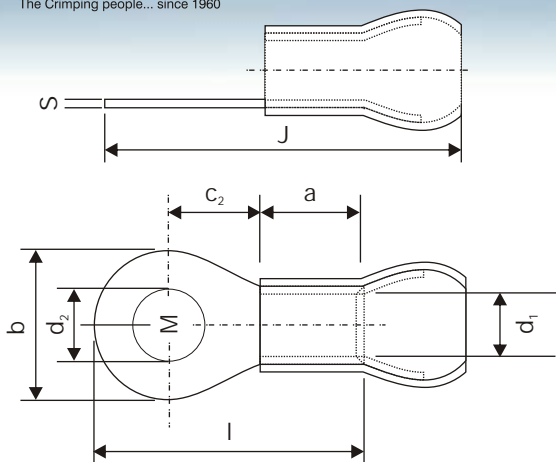

Conductor mm ²	Bolt Ø	3D CAT NO.	Dimensions in mm									Tools	pcs
			d ₁	b	d ₂	s	a	d ₃	C ₂	l	J		
0.5 To 1.5mm ²	M 2.5	3D-3337	1.6	6	2.6	0.8	5	3.2	4	16	19	3D-41	100
	M 3	3D-3338	1.6	6	3.2	0.8	5	3.2	4	14	19		
	M 3	3D-3341	1.6	6.8	3.2	0.8	5	3.2	3.6	13	18		
	M 3	3D-3344	1.6	8	3.2	0.8	5	3.2	5	16	21		
	M 3.5	3D-3366	1.6	7.2	3.7	0.8	5	3.2	4	14	21		
	M 3.5	3D-3339	1.6	6	3.7	0.8	5	3.2	4	14	19		
	M 3.5	3D-3342	1.6	6.8	3.7	0.8	5	3.2	3.8	13	18		
	M 4	3D-3340	1.6	6	4.2	0.8	5	3.2	4	14	19		
	M 4	3D-3343	1.6	6.8	4.2	0.8	5	3.2	3.6	13	18		
	M 4	3D-3345	1.6	8	4.2	0.8	5	3.2	5	16	21		
	M 4	3D-3347	1.6	7	4.2	0.8	5	3.2	5	14.5	19.5		
	M 4	3D-3348	1.6	10	4.2	0.8	5	3.2	6	18	23		
	M 5	3D-3346	1.6	8	5.2	0.8	5	3.2	5	16	21		
	M 5	3D-3349	1.6	10	5.2	0.8	5	3.2	6	18	23		
2.5mm ²	M 6	3D-3350	1.6	10	6.4	0.8	5	3.2	6	18	23	3D-41	100
	M 6	3D-3351	1.6	12	6.4	0.8	5	3.2	6	18	23		
	M 3	3D-3382	2.3	6.5	3.2	0.8	5	3.9	3.5	12.7	17.8		
	M 3.5	3D-3383	2.3	6.5	3.7	0.8	5	3.9	3.5	12.7	17.7		
	M 3.5	3D-3384	2.3	8	3.7	0.8	5	3.9	5	16	21		
	M 4	3D-3385	2.3	8	4.2	0.8	5	3.9	5	16	21		
	M 5	3D-3386	2.3	8	5.2	0.8	5	3.9	5	16	21		
	M 5	3D-3387	2.3	10	5.2	0.8	5	3.9	7	18	23		
	M 5	3D-3389	2.3	12	5.2	0.8	5	3.9	9	22	27		
	M 6	3D-3388	2.3	10	6.4	0.8	5	3.9	7	18	23		
	M 6	3D-3390	2.3	12	6.4	0.8	5	3.9	9	22	27		
	M 6	3D-3392	2.3	16	6.4	0.8	5	3.9	10	25	30		
	M 8	3D-3391	2.3	12	8.2	0.8	5	3.9	9	22	27		
	M 8	3D-3393	2.3	16	8.2	0.8	5	3.9	10	25	30		
M 10	3D-3394	2.3	16	10.2	0.8	5	3.9	10	25	30			
M 10	3D-3395	2.3	18	10.2	0.8	5	3.9	14	29	34			
M 12	3D-3396	2.3	18	12.7	0.8	5	3.9	14	29	34			



The Crimping people... since 1960

Sheet Metal Lugs, Ring Type

Double Grip With Insulating Sleeve
 Material: E-Copper + PVC
 Surface: Tin Plated

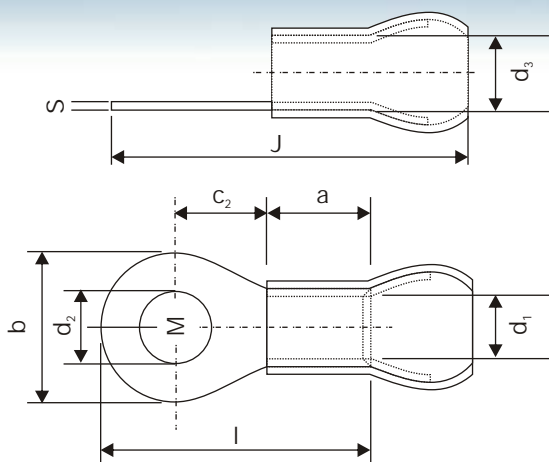

Conductor mm ²	Bolt Ø	3D CAT NO.	Dimensions in mm									Tools	pcs
			d ₁	d ₃	d ₂	b	s	a	C ₂	L	J		
4 - 6mm ²	M 4	3D-3493	3.5	5.5	4.2	8	1	6	5	17	26	3D-41	100
	M 4	3D-3495	3.5	5.5	4.2	10	1	6	5	19	28		
	M 5	3D-3494	3.5	5.5	5.2	8	1	6	5	17	26		
	M 5	3D-3496	3.5	5.5	5.2	10	1	6	5	19	28		
	M 5	3D-3497	3.5	5.5	5.2	8	1	6	9.8	22.8	31.8		
	M 5	3D-3498	3.5	5.5	5.2	12	1	6	6	20	29		
	M 5	3D-3501	3.5	5.5	5.2	12	1	6	7	22	31		
	M 6	3D-3499	3.5	5.5	6.4	12	1	6	6	20	29		
	M 6	3D-3502	3.5	5.5	6.4	12	1	6	7	22	31		
	M 6	3D-3503	3.5	5.5	6.4	14	1	6	10.5	25.5	34.5		
	M 8	3D-3500	3.5	5.5	8.2	12	1	6	6	20	29		
	M 8	3D-3504	3.5	5.5	8.2	14	1	6	10.5	25.5	34.5		
	M 8	3D-3506	3.5	5.5	8.2	16	1	6	13	30	39		
	M 8	3D-3508	3.5	5.5	8.2	18	1	6	12	30	39		
	M 9	3D-3505	3.5	5.5	9.7	14	1	6	10.5	25.5	34.5		
	M 10	3D-3507	3.5	5.5	10.2	16	1	6	13	30	39		
	M 10	3D-3509	3.5	5.5	10.2	18	1	6	12	30	39		
	M 12	3D-3510	3.5	5.5	12.7	18	1	6	12	30	39		



The Crimping people... since 1960

Sheet Metal Lugs, Fork Type

Standard Type, Brazed Seam
Material: E-Copper
Surface: Tin Plated

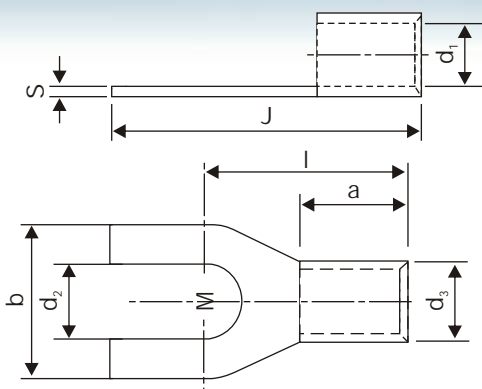

Conductor mm ²	Bolt Ø	3D CAT NO.	Dimensions in mm								Tools	pcs
			d ₁	b	d ₂	s	a	d ₃	l	J		
0.5 To 1.5mm ²	M 2	3D-1709	1.6	4.6	2.3	0.8	5.0	3.2	10.6	13	3D-2 3D-17	100
	M 3	3D-1923	1.6	6.0	3.1	0.8	5.0	3.2	11.0	14		
	M 3.5	3D-1699	1.6	6.8	3.6	0.8	5.0	3.2	11.1	14.5		
	M 3.5	3D-1700	1.6	6.0	3.6	0.8	5.0	3.2	11.0	14		
	M 4	3D-1701	1.6	8.0	4.1	0.8	5.0	3.2	12.0	16		
	M 4	3D-1704	1.6	6.5	4.1	0.8	5.0	3.2	11.0	15		
	M 5	3D-1875	1.6	8.0	5.1	0.8	5.0	3.2	12.0	16		
	M 5	3D-1702	1.6	10.0	5.1	0.8	5.0	3.2	13.0	18		
2.5mm ²	M 5	3D-1698	1.6	8.0	5.1	0.8	5.0	3.2	17.0	21	3D-17 3D-2	100
	M 3	3D-1902	2.4	5.6	3.1	0.8	5.0	4	10.0	14		
	M 3	3D-1889	2.3	6.0	3.1	0.8	5.0	3.9	11.0	14		
	M 3.5	3D-1890	2.3	6.0	3.6	0.8	5.0	3.9	11.0	14		
	M 3.5	3D-1884	2.3	6.5	3.6	0.8	5.0	3.9	11.8	15		
	M 4	3D-1898	2.3	6.5	4.1	0.8	5.0	3.9	11.8	15		
	M 4	3D-1891	2.3	8.0	4.1	0.8	5.0	3.9	12.0	16		
	M 5	3D-1892	2.3	10.0	5.1	0.8	5.0	3.9	14.0	19		
4mm ² To 6mm ²	M 5	3D-1903	2.6	10.6	5.0	1.0	6.2	4.6	15.7	21	3D-17 3D-2	100
	M 6	3D-1896	2.3	10.0	6.5	0.8	5.0	3.9	14.0	19		
	M 3	3D-1906	3.5	6.0	3.1	1.0	6.0	5.5	11.5	15		
	M 3.5	3D-1907	3.5	6.0	3.6	1.0	6.0	5.5	11.0	15		
	M 4	3D-1733	3.5	8.0	4.1	1.0	6.0	5.5	13.0	17		
	M 4	3D-1914	3.6	8.0	4.1	1.0	6.0	5.6	14.0	18		
	M 5	3D-1734	3.5	8.0	5.1	1.0	6.0	5.5	13.0	17		
10mm ²	M 5	3D-1916	3.6	10.0	5.1	1.0	6.0	5.6	15.0	20	3D-2	100
	M 6	3D-1915	3.6	11.0	6.4	1.0	6.0	5.6	16.0	21.5		
16mm ²	M 6	3D-1917	4.5	16.0	6.5	1.2	8.0	6.9	19.0	27	3D-2	100
	M 8	3D-1918	4.5	16.0	8.2	1.2	8.0	6.9	19.0	27		
16mm ²	M 5	3D-1922	5.3	10.0	5.1	1.2	10.0	7.7	20.0	26	3D-2	50



The Crimping people... since 1960

Sheet Metal Lugs, Fork Type

Standard Type, with Insulating Sleeve

Material: E-Copper

With PVC Sleeve

Surface: Tin Plated

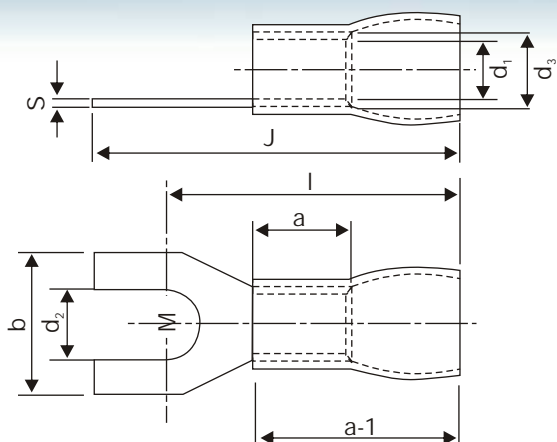

Conductor mm ²	Bolt Ø	3D CAT NO.	Dimensions In mm										Tools	pcs
			d ₁	b	d ₂	s	a	a-1	d ₃	l	J			
0.5 to 1.5mm ²	M 2	3D-3695	1.6	4.6	2.3	0.8	5	11	3.2	15.2	18	3D-41	100	
	M 3	3D-3640	1.6	6	3.1	0.8	5	11	3.2	16	19			
	M 3.5	3D-3641	1.6	6	3.6	0.8	5	11	3.2	16	19			
	M 3.5	3D-3639	1.6	6.8	3.5	0.8	5	11	3.2	15	19			
	M 4	3D-3647	1.6	6.5	4.1	0.8	5	11	3.2	16	20			
	M 4	3D-3642	1.6	8	4.1	0.8	5	11	3.2	17	21			
	M 5	3D-3650	1.6	8	5.1	0.8	5	11	3.2	17	21			
	M 5	3D-3643	1.6	10	5.1	0.8	5	11	3.2	19	23			
	M 5	3D-3638	1.6	8	5.1	0.8	5	11	3.2	22	26			
2.5mm ²	M 3	3D-3671	2.4	5.6	3.1	0.8	5	11	4	15	19	3D-41	100	
	M 3	3D-3661	2.3	6	3.1	0.8	5	11	3.9	16	19			
	M 3.5	3D-3662	2.3	6	3.6	0.8	5	11	3.9	16	19			
	M 3.5	3D-3657	2.3	6.5	3.5	0.8	5	11	3.9	16.8	20			
	M 4	3D-3663	2.3	8	4.1	0.8	5	11	3.9	17	21			
	M 4	3D-3668	2.3	6.5	4.1	0.8	5	11	3.9	16.8	20			
	M 5	3D-3664	2.3	10	5.1	0.8	5	11	3.9	19	24			
	M 5	3D-3673	2.6	10.6	5.0	1	6.2	11	4.6	20	25			
	M 6	3D-3670	2.3	10	6.4	0.8	5	11	3.9	19	24			
4mm ² To 6mm ²	M 3	3D-3674	3.5	6	3.1	1	6	14	5.5	21	24	3D-41	100	
	M 3.5	3D-3675	3.5	6	3.5	1	6	14	5.5	21	24			
	M 4	3D-3679	3.6	8	4.1	1	6	14	5.6	23	27			
	M 4	3D-3720	3.5	8	4.1	1	6	11	5.5	21	25			
	M 5	3D-3721	3.5	8	5.1	1	6	11	5.5	21	25			
	M 5	3D-3681	3.6	10	5.1	1	6	14	5.6	24	29			
	M 6	3D-3680	3.6	11	6.4	1	6	14	5.6	25	30.5			



The Crimping people... since 1960

Sheet Metal Lugs, Fork Type

Double Grip, With Insulating Sleeve
Material: E-Copper With PVC Sleeve
Surface: Tin Plated

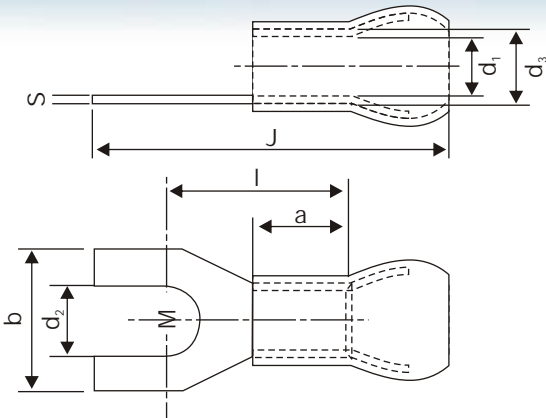

Conductor mm ²	Bolt Ø	3D CAT NO.	Dimensions in mm								Tools	pcs
			d ₁	d ₃	d ₂	b	s	a	l	J		
0.5 to 1.5mm ²	M 3.5	3D-3685	1.6	3.2	3.5	6.8	0.8	4	14.8	19	3D-41	100
2.5mm ²	M 3.5	3D-3687	2.3	3.9	3.5	6.5	0.8	5	16.8	20	3D-41	100
4mm ² to 6mm ²	M 3	3D-3689	3.5	5.5	3.1	6	1	6	20.5	24	3D-41	100
	M 3.5	3D-3690	3.5	5.5	3.5	6	1	6	20	24		

Sheet Metal Lugs, Rectangular Pin Type

Brazed Seam,
Material : E Copper
Surface : Tin Plated

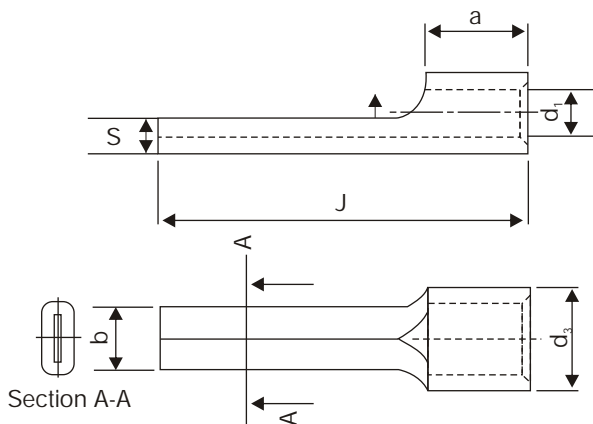

Conductor mm ²	3D CAT NO.	Dimensions in mm						Tools	pcs
		d ₁	d ₃	b	s	a	J		
10mm ²	3D-1041	4.3	6.7	4.3	2.4	8	22	3D-17	100
16mm ²	3D-1042	5.3	7.3	2.7	2	10	25	3D-17	50
16mm ²	3D-1043	5.8	8.2	5.5	2.4	10	26.0	3D-17	50
25mm ²	3D-1044	7.5	11.1	7.0	3.6	11	31.0	3D-109	50
35mm ²	3D-1045	9.0	12.6	8.0	3.6	12	37.0	3D-109	50
50mm ²	3D-1046	10.5	14.1	9.0	3.6	16	42.0	3D-109	50
70mm ²	3D-1047	12.0	16.0	10.0	4	18	45.0	3D-109	25



The Crimping people... since 1960

Sheet Metal Lugs, Round Pin Type

W/O Sleeve, Brazed Seam
Material: E-Copper
Surface: Tin Plated

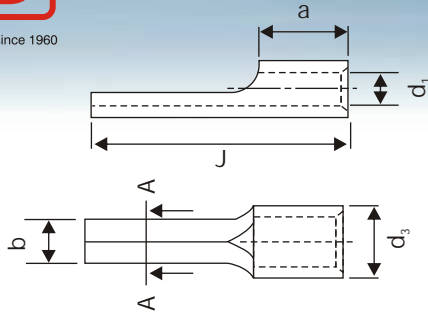
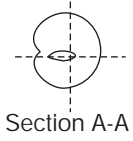

Conductor mm ²	3D CAT NO.	Dimensions in mm					Tools	pcs
		d ₁	d ₃	b	a	J		
0.5 To 1.5mm ²	3D-1012	1.6	3.2	1.9	5	17	3D-17 3D-2	100
	3D-1015	1.6	3.2	1.9	5	14		
	3D-1019	1.8	3.2	1.9	5	17		
2.5mm ²	3D-1020	2.4	4	1.7	4.2	14.4	3D-17 3D-2	100
	3D-1021	2.3	3.9	1.9	5	17		
	3D-1023	2.3	3.9	1.9	5	21		
4mm ²	3D-1028	2.8	4.5	1.7	4.2	14.4	3D-17 3D-2	100
	3D-1030	2.9	4.9	2.7	6	20		
6mm ²	3D-1037	3.6	5.6	2.6	6.4	20.4	3D-17 3D-2	100
	3D-1036	3.6	5.6	2.7	6	20		
	3D-1039	4	6	2.7	6	20		

Sheet Metal Lugs, Round Pin Type

With Insulating Sleeve
Material: E-Copper With PVC Sleeve
Surface: Tin Plated

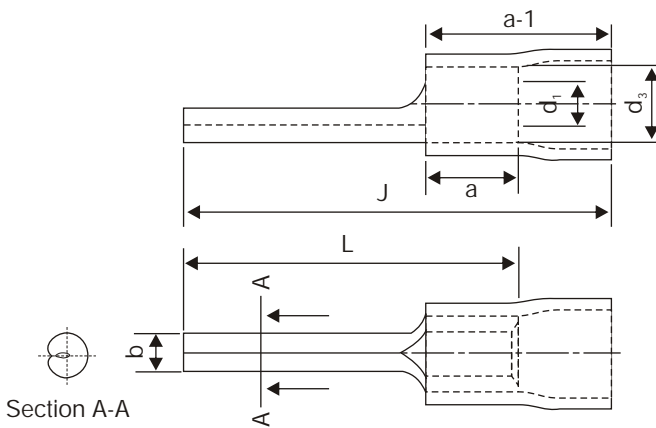

Conductor mm ²	3D CAT NO.	Dimensions in mm						Tools	pcs
		d ₁	d ₃	b	a	a-1	J		
0.5 To 1.5mm ²	3D-3008	1.6	3.2	1.9	5	11	22	3D-41	100
	3D-3013	1.6	3.2	1.9	5	11	19		
	3D-3020	1.8	3.8	1.9	5	11	22		
2.5mm ²	3D-3022	2.3	3.9	1.9	5	11	22	3D-41	100
4mm ² to 6mm ²	3D-3026	2.9	4.9	2.7	6	14	28	3D-41	100



The Crimping people... since 1960

Sheet Metal Lugs, Round Pin Type

Double Grip, With Insulating Sleeve
 Material: E-Copper With PVC Sleeve
 Surface: Tin Plated

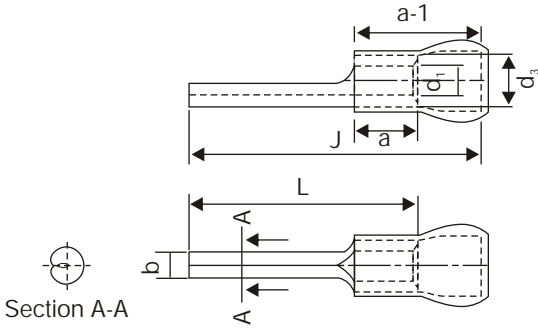

Conductor mm ²	3D CAT NO.	Dimensions in mm								Tools	pcs
		d ₁	d ₃	b	s	a	a-1	J	L		
0.5 to 1.5mm ²	3D-3040	1.6	3.2	1.9	0.8	5	11	22	17	3D-41	100
2.5mm ²	3D-3043	2.3	3.9	1.9	0.8	5	11	22	17	3D-41	100
4mm ² to 6mm ²	3D-3046	2.9	4.9	2.7	1	6	14	29	20	3D-41	100

Sheet Metal Lugs, Flat Pin Type

Standard Type Sleeve, Brazed Seam
 Material: E-Copper
 Surface: Tin Plated

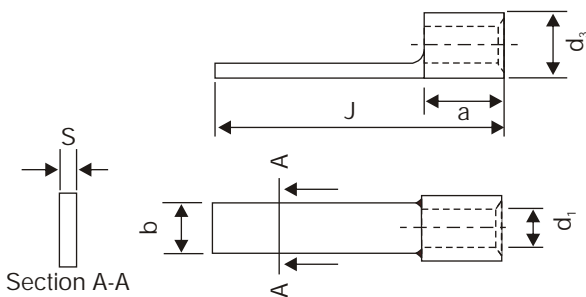

Conductor mm ²	3D CAT NO.	Dimensions in mm						Tools	pcs
		d ₁	d ₃	b	s	a	J		
0.5 to 1.5mm ²	3D-1011	1.6	3.2	3.1	0.8	5	17	3D-17	100
	3D-1013	1.6	3.2	2.3	0.8	5	15.5	3D-2	
	3D-1014	1.6	3.2	2.3	0.8	5	23.5		
2.5mm ²	3D-1022	2.3	3.9	3.1	0.8	5	17	3D-17	100
	3D-1027	2.4	4	3.1	0.8	4.2	14.4		
	3D-1024	2.3	3.9	2.3	0.8	5	23.5		
	3D-1025	2.3	3.9	2.8	0.8	5	14		
	3D-1029	2.8	4.4	3.1	0.8	4.2	14.4		
4mm ² To 6mm ²	3D-1032	3.6	5.6	5.1	1	6	20	3D-17	
	3D-1035	3.4	5.5	5.1	1	6.35	20.6		
	3D-1038	3.6	5.6	2.8	1	6	16		



The Crimping people... since 1960

Sheet Metal Lugs, Insulated Flat Pin Type

With Insulating Sleeve
Material: E-Copper With PVC Sleeve
Surface: Tin Plated

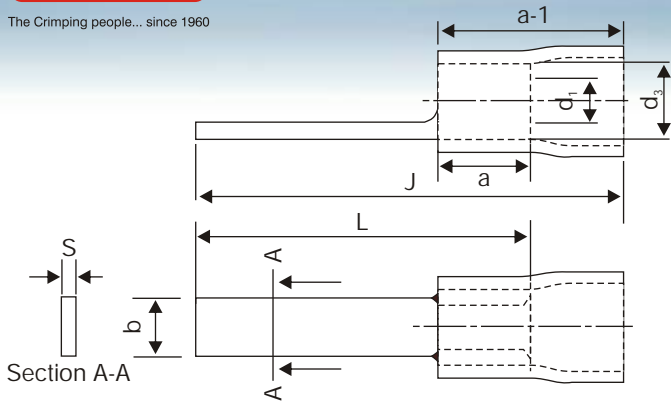

Conductor mm ²	3D CAT NO.	Dimensions In mm								Tools	pcs
		d ₁	d ₃	b	s	a	a-1	J	L		
0.5 To 1.5mm ²	3D-3009	1.6	3.2	3.1	0.8	5	11	22	17	3D-41	100
	3D-3011	1.6	3.2	2.3	0.8	5	11	20.5	15.5		
	3D-3012	1.6	3.2	2.3	0.8	5	11	28.5	23.5		
2.5mm ²	3D-3023	2.3	3.9	3.1	0.8	5	11	22	17	3D-41	100
	3D-3025	2.3	3.9	2.3	0.8	5	11	28.5	23.5		
4mm ² to 6mm ²	3D-3027	3.6	5.6	5.1	1	6	14	36	20		

35

Sheet Metal Lugs, Insulated Flat Pin Type Double Grip

With Insulating Sleeve
Material: E-Copper With PVC Sleeve
Surface: Tin Plated

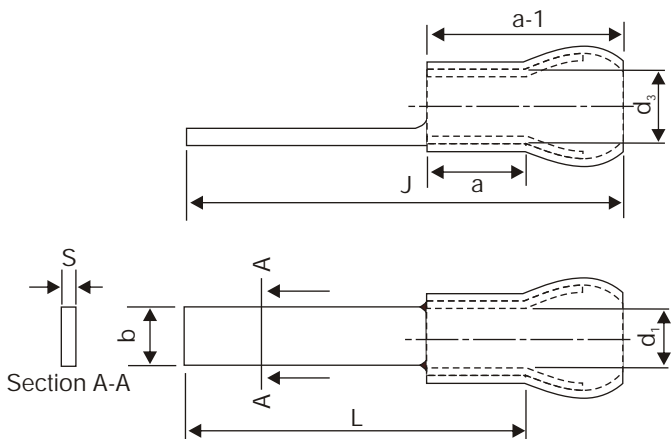

Conductor mm ²	3D CAT NO.	Dimensions In mm								Tools	pcs
		d ₁	d ₃	b	s	a	a-1	J	L		
2.5mm ²	3D-3044	2.3	3.9	3.1	0.8	5	11	22	17	3D-41	100



The Crimping people... since 1960

Brass / Copper Connectors, Male / Female Disconnects with Tin Plated



Receptacle Connectors



Vinyl Ins. Butt Connectors (Copper Tube)



Nylon Ins. Butt Connectors



Heat Shrinkable Butt Connectors With Water Proof

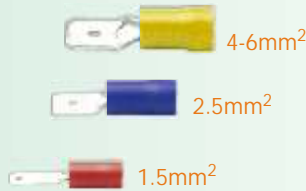

Male Disconnects



Female Disconnects

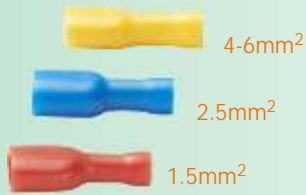

Fully Insulated Female



Piggy Back Disconnects



Female Nylon Insulated Disconnects



Male Nylon Insulated Disconnects



Wire Nuts



Bullet Connectors



The Crimping people... since 1960

Bus Bar & Transformer Type Cable Lugs & Brass Connectors with Tin Plated



Stripping Quick Splice



Vinyl Ins. Butt Connectors (Copper Tube)



Nylon Ins. Butt Connectors



Close End Connectors



Terminals For Transformer Strip Binding



Copper Terminal



Copper Bus Bar



Copper Bus Bar



T Aluminium & Copper Connector



X Aluminium & Copper Connector



Copper Earthing Strips Plain & Perforated



The Crimping people... since 1960

Hand Crimping Tool - 3D-17



EN 19 made jaw

Ratchet mechanism for quick locking and unlocking



Spring steel handles to give strength and durability to the tool. Rubber grips provide ergonomic handling.



- Crimping tool for non-insulated brazed copper terminals and connectors.
- Crimping range is from 1.5mm² to 6mm².
- The jaw is made from EN 19 and handles from spring steel giving strength and durability to the tool. Rubber grips provide ergonomic handling and good grip.
- Ratchet mechanism for quick locking and unlocking.



Hand Crimping Tool - 3D-2



Spring steel handles to give strength and durability to the tool. Rubber grips provide ergonomic handling.

Ratchet mechanism for quick locking and unlocking

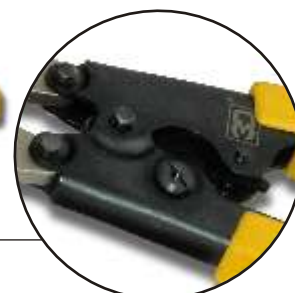

EN 19 made jaw

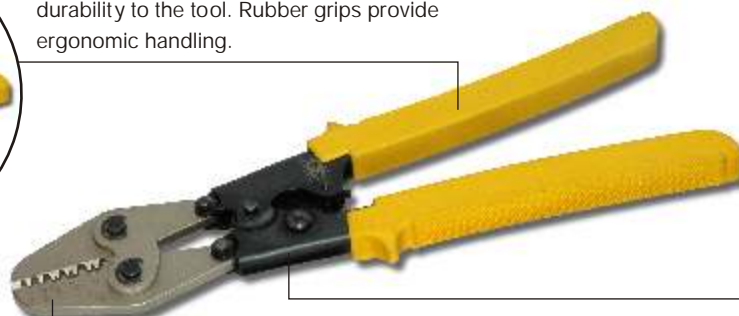

- Crimping tool for non-insulated brazed copper terminals, tubular lugs and connectors.
- Crimping range is from 1.5mm² to 16mm².
- The jaw is made from EN 19 and handles from spring steel giving strength and durability to the tool. Rubber grips provide ergonomic handling and a good grip.
- Ratchet mechanism for quick locking and unlocking.





The Crimping people... since 1960

Hand Crimping Tool - 3D-41

New

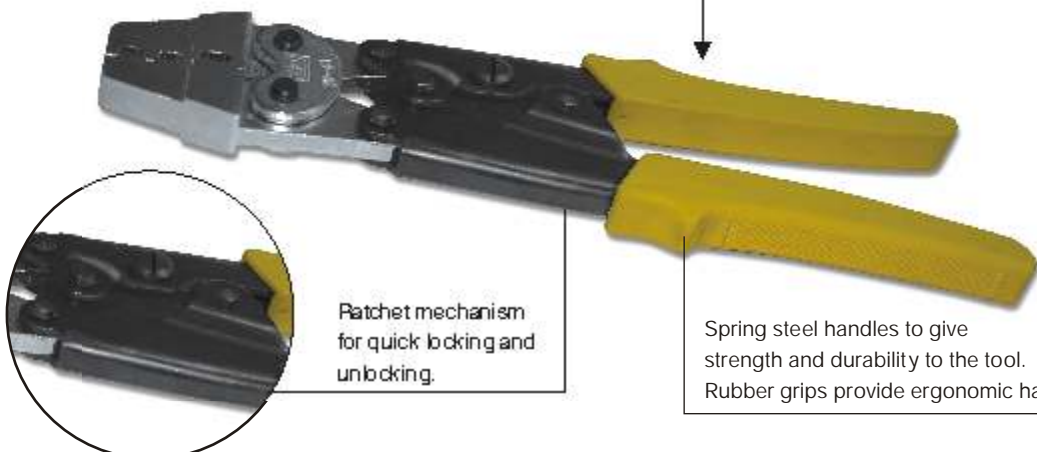

Ratchet mechanism for quick locking and unlocking.

The jaws are made from EN 19. The ergonomic grips are made from polypropylene.

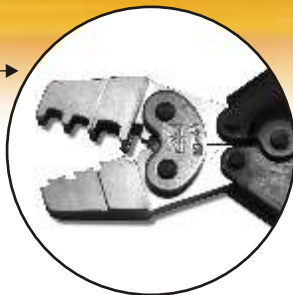

Spring steel handles to give strength and durability to the tool. Rubber grips provide ergonomic handling.



- Crimping tool for PVC/Nylon insulated, double grip, terminals and connectors.
- Crimping range is from 1.5mm² to 6mm².
- The jaws are made from EN 19.
- The handles are made from spring steel giving strength and durability to the tool. Rubber grips Provide ergonomic handling and a good grip.
- Ratchet mechanism for quick locking and unlocking. The crimping pressure can also be adjusted to accommodate different terminal sizes.



Hand Crimping Tool - 3D-48



EN 19 forging flat made jaw, 8mm thick to accommodate all lengths of end sleeves.



Spring steel handles to give strength and durability to the tool. Rubber grips provide ergonomic handling.

Ratchet mechanism for quick locking and unlocking

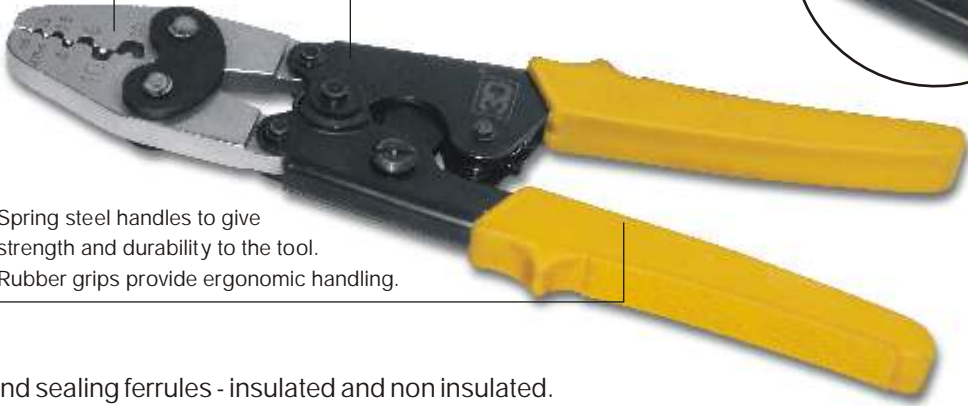

- Crimping tool for end sealing ferrules - insulated and non insulated.
- Crimping range is from 0.5mm² to 16mm².
The jaw is made from EN 19 forging flat and is 8mm thick to accommodate all lengths of end sleeves.
- Crimp profile is v-shaped.
- The handles are made from spring steel giving strength and durability to the tool. Rubber grips Provide ergonomic handling and a good grip.
- Ratchet mechanism for quick locking and unlocking





The Crimping people... since 1960

Hand Crimping Tool - 3D-52



EN 19 forging flat made jaw, 8mm thick to accommodate all lengths of end sleeves.



Ratchet mechanism for quick locking and unlocking.



The handles are made from spring steel giving strength and durability to the tool. Rubber grips provide ergonomic handling and a good grip.



- Crimping tool for end sealing ferrules - insulated and non insulated.
- Crimping range is from 0.5mm² to 6mm²
- The jaw is made from EN 19 forging flat and is 8mm thick to accommodate all lengths of end sleeves.
- Crimp profile is trapezoid-shaped.
- The handles are made from spring steel giving strength and durability to the tool. Rubber grips provide ergonomic handling and a good grip.
- Ratchet mechanism for quick locking and unlocking.

Hand Crimping Tool - 3D-53



The jaw is made from EN 19 forging flat to accommodate all lengths of end sleeves.



Spring steel handles to give strength and durability to the tool. Rubber grips provide ergonomic handling.

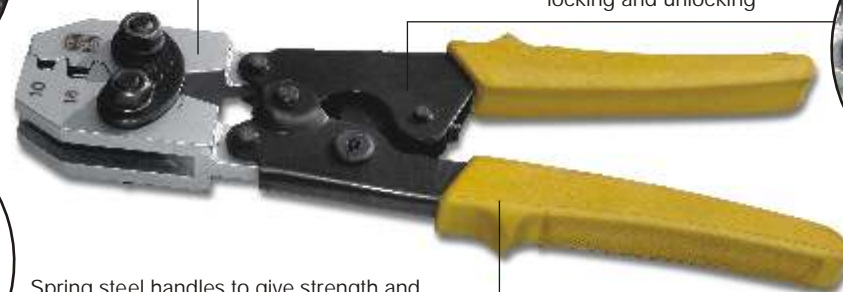

Ratchet mechanism for quick locking and unlocking

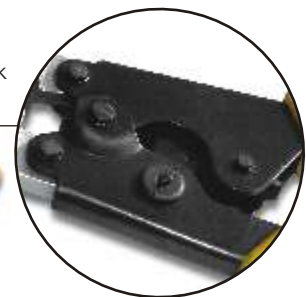

- Crimping tool for end sealing ferrules - insulated and non insulated.
- Crimping range is from 10mm² to 16mm²
- The jaw is made from EN 19 forging flat to accommodate all lengths of end sleeves.
- Crimp profile is trapezoid-shaped.
- The jaw is made from EN 19 and handles from spring steel giving strength and durability to the tool. Rubber grips provide ergonomic handling and a good grip.
- Ratchet mechanism for quick locking and unlocking.



The Crimping people... since 1960

Hand Crimping Tool - 3D-95

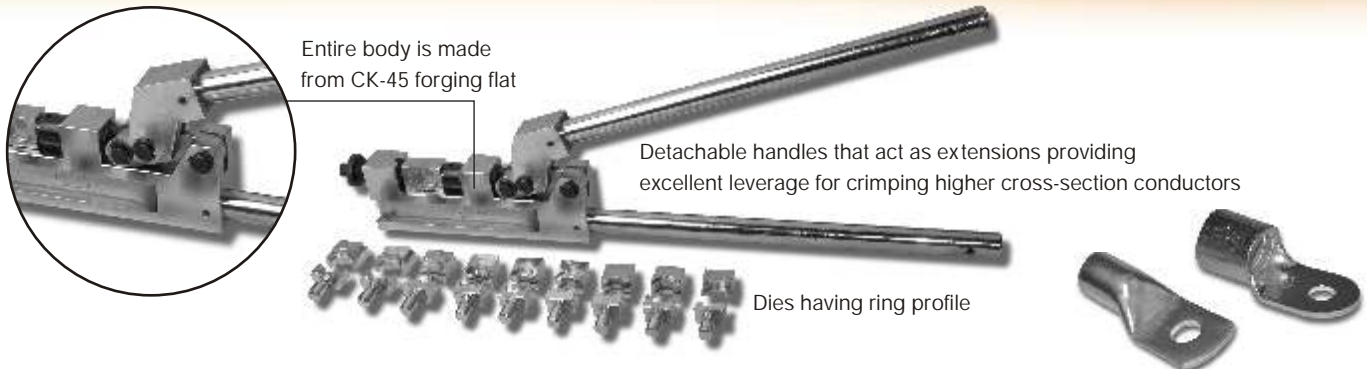

- Single tool accommodates a wide array of terminals (copper and aluminum).
- Entire body is made from CK-45 forging flat. It is chrome plated for corrosion resistance and finish.
- Detachable handles that act as extensions providing excellent leverage for crimping higher cross-section conductors.

3D-95 VARIANTS	CRIMPING CAPACITY	DESCRIPTION	STD. DIES	HANDLE
3D-95R	10 - 95 mm ²	For Cu Light duty/ Al. terminals . with Al. cables	Ring dies > 10 ² , 16 ² , 25 ² , 35 ² , 50 ² , 70 ² , 95 ²	Not Included
3D-96	10 - 185 mm ²	For Cu Light duty/ Al. terminals . with Al. cables	Ring dies > 10 ² , 16 ² , 25 ² , 35 ² , 50 ² , 70 ² , 95 ² , 120 ² , 150 ² , 185 ²	Included
3D-95H	2.5 - 185 mm ²	For Al terminals to Al. cables	Hex dies > 2.5 ² to 185 ²	Included
3D-107H	2.5 - 185 mm ²	For Cu Light duty to Al cables	Included	Included
3D-108H	1.5 - 185 mm ²	For Cu terminals to Cu Cables	Hex dies > 1.5 ² to 185 ²	Included
3D-109	10 - 95 mm ²	For Ring Terminals	10 - 95 mm ²	Not Included
3D-110	25 - 185 mm ²	For End Sealing Ferrules	25 ² to 185 ²	Included

41

Dieless Tool - 3D-95B

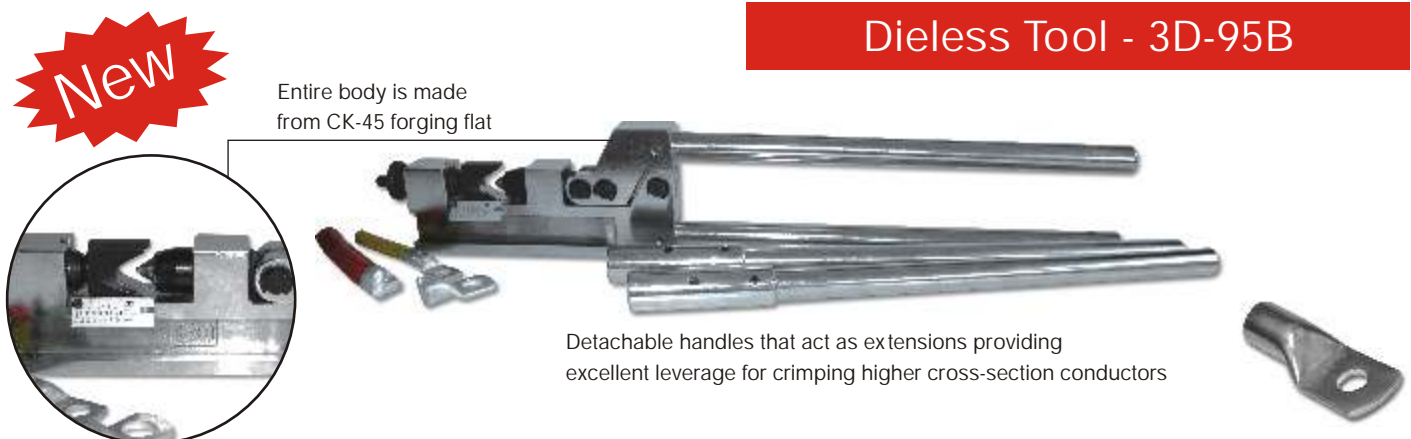

- Designed for Al Lugs & Connectors (as per IS standards) and Cu. Light duty lugs only
- Entire body is made from CK-45 forged flat. It is chrome plated for corrosion resistance & finish.
- Crimping range is from 10 to 185mm²
- Detachable handles that act as extensions providing excellent leverage for crimping higher cross-section conductors.
- Not recommended for Sheet metal lugs.
- Tool can adopt to conventional ring and hex dies.



The Crimping people... since 1960

Hand Crimping Tool - 3D-7

chrome plated for corrosion resistance
made from CK-45 forged flat

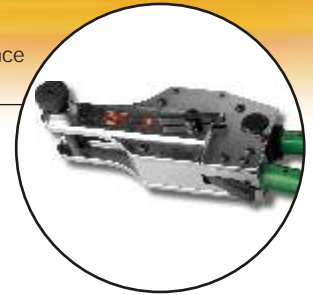

Dies having hexagonal profile

- The mail body is made from CK-45 forged flat. High strength and durability. It is CNC machined for accuracy and finish.
- It is chrome plated for corrosion resistance.
- Cam- Gear powered mechanism for efortless crimping and automatic release of die.

3D-7 VARIANTS	CRIMPING CAPACITY	DESCRIPTION	STD. DIES	EXTRA DIES *	
				CAT NO.	FOR CONDUCTOR (mm2)
3D-7	2.5 - 400 mm ²	For Crimping Al. terminals / connectors Al. cables	120 ² , 150 ² , 185 ² , 240 ² , 300 ² , 400 ²	3D-316 3D-317 3D-318 3D-319 3D-320	10 ² , 16 ² , 25 ² 2.5 ² , 4 ² , 6 ² , 35 ² 50 ² 70 ² 95 ²
3D-116	2.5 - 400 mm ²	For Crimping Copper light duty terminals/ connectors to Al. cables	120 ² , 150 ² , 185 ² , 240 ² , 300 ² , 400 ²	3D-641 3D-642 3D-643 3D-644 3D-645	10 ² , 16 ² , 25 ² 4 ² , 6 ² , 35 ² 2.5 ² , 50 ² 70 ² 95 ²
3D-117	1.5 - 400 mm ²	For Crimping Heavy duty copper terminals / connectors to XLPE Cu. Cables.	120 ² , 150 ² , 185 ² , 240 ² , 300 ² , 400 ²	3D-652 3D-653 3D-654 3D-655 3D-656	10 ² , 16 ² , 25 ² 4 ² , 6 ² , 35 ² 1.5 ² , 2.5 ² , 50 ² 70 ² 95 ²

* Extra dies on extra payment

Cable Cutter - 3D-31

Made from EN 42 steel, very durable and the blade retains sharp edge after prolonged use.



Entire tool is blackened to resist corrosion.



- Wire cutting tool with a range of 6mm diameter.
- Light weight and simple to use.
- Made from EN 42 steel, very durable and the blade retains sharp edge after prolonged use.
- Entire tool is blackened to resist corrosion.



The Crimping people... since 1960

Heavy Duty Crimping Tool - 3D-150



Chrome plated MS body for corrosion resistance

Hand operated hydraulic pump



- Highly versatile tool for heavy-duty crimping upto 1000 mm²
- Chrome plated MS body for corrosion resistance.
- Hydraulic pump (3D-149) which is hand operated and exerts a pressure of 350 kg/cm³
- Optional trolley and pressure gauge can be provided for easy movement.

43

3D-150 VARIANTS	CRIMPING CAPACITY	DESCRIPTION	STD. DIES	EXTRA DIES *	
				CAT NO.	FOR CABLE (mm ²)
3D-120H	25 - 1000 mm ²	For Cu. Terminals/ connectors to Cu Std. And XLPE cables	120 ² , 150 ² , 185 ² , 240 ² , 300 ² , 400 ²	3D-701 3D-702 3D-703 3D-704 3D-705 3D-734 3D-735 3D-736 3D-737	25 ² 35 ² 50 ² 70 ² 95 ² 500 ² 630 ² 800 ² 1000 ²
3D-121H	25 - 1000 mm ²	For Cu. Economy terminals And Au cables	120 ² , 150 ² , 185 ² , 240 ² , 300 ² , 400 ²	3D-709 3D-710 3D-711 3D-712 3D-713 3D-738 3D-739 3D-740 3D-741	25 ² 35 ² 50 ² 70 ² 95 ² 500 ² 630 ² 800 ² 1000 ²
3D-150R	120 - 1000 mm ²	For Al./ Cu. Light duty Terminals / Connectors. to Ac cables	120 ² , 150 ² , 185 ² , 240 ² , 300 ² , 400 ²	3D-541 3D-542 3D-543 3D-544 3D-545 3D-546 3D-547	630 ² Cu. Terminals 500 ² Al. Terminals 630 ² Al. Terminals 1000 ² Cu. Terminals 800 ² Cu. Terminals 800 ² Al. Terminals 1000 ² Al. Terminals
3D-150H	25 - 1000 mm ²	For Al./ terminals/ connectors with Al. cables	120 ² , 150 ² , 185 ² , 240 ² , 300 ² , 400 ²	3D-717 3D-718 3D-328 3D-329 3D-330 3D-501 3D-502 3D-503 3D-504	25 ² 35 ² 50 ² 70 ² 95 ² 500 ² 630 ² 800 ² 1000 ²

* Extra dies on extra payment



The Crimping people... since 1960

Heavy Duty Crimping Tool - 3D-100



- Hand operated hydraulic crimping tool for aluminium and copper lugs ranging from 25 to 400mm²
- Lightweight head is made from EN-19 and is blackened for corrosion resistance.
- The handle is knurled for extra grip.

3D-100 VARIANTS	CRIMPING CAPACITY	DESCRIPTION	STD. DIES	EXTRA DIES *	
				CAT NO.	FOR CONDUCTOR (mm ²)
3D-100	25 - 400 mm ²	For Copper terminals and connectors to . Cu. Std And XLPE cables.	120 ² , 150 ² , 185 ² , 240 ² , 300 ² , 400 ²	3D-781 3D-782 3D-783 3D-784 3D-785	25 ² 35 ² 50 ² 70 ² 95 ²
3D-125	25 - 400 mm ²	For Cu Light duty and connectors to Al. cables	120 ² , 150 ² , 185 ² , 240 ² , 300 ² , 400 ²	3D-794 3D-795 3D-796 3D-797 3D-798	25 ² 35 ² 50 ² 70 ² 95 ²
3D-124	25 - 400 mm ²	For Al terminals and connectors to Al. cables	120 ² , 150 ² , 185 ² , 240 ² , 300 ² , 400 ²	3D-807 3D-808 3D-809 3D-810 3D-811	25 ² 35 ² 50 ² 70 ² 95 ²
3D-100A New	500 - 630 mm ²	For Al terminals and Cu Light duty terminals and connectors	500 ² , 630 ²	3D-818 3D-819	500 ² 630 ²

* Extra dies on extra payment



The Crimping people... since 1960

Cable Cutter - 3D-30



Made from EN 47 steel, very durable and the blade retains sharp edge after prolonged use.



Can cut upto dia 40



The hosing is a quick-release hose which is leak proof.



- Armoured aluminium and copper cable cutting tool with a range of 40 mm diameter. Cutting is done with a Hand-operated hydraulic pump(3D-170).
- Light weight and simple to use.
- Made from EN 47 steel, very durable and the blade retains sharp edge after prolonged use.
- It features a light weight but robust forged head that fits nicely into the operator's hand.
- Entire tool is blackened to resist corrosion.
- The pump is light and portable, a must for onsite usage. The hosing is a quick-release hose which is leak proof. It can provide a pressure of 250 kg/cm³.

45

Hand Crimping Tool - 3D-88



Head is made from cast EN-19

Body is made from CK-45 forged flat



- Hand operated hydraulic crimping tool for tubular copper - heavy duty and copper economy and aluminum lugs.
- Body is made from CK-45 forged flat. The crimping head is made from cast EN-19. Tool is light in weight and robust for rough handling.
- The crimping head is interlocking and swivels 180 degrees for quick change of dies.
- Crimping range is from 10 to 120mm²
- Crimping is complete within 20 strokes.
- Comes with a wooden box with excellent finish
- The dies are made from EN-19 forging flat and are chrome plated for corrosion resistance.





The Crimping people... since 1960

Quality Policy

We, at **billets ELEKTRO WERKE Ltd.**
are committed to achieving full
customer satisfaction and enhancing it.
This commitment is shared by all our
employees and is an integral part of the
fundamental value system of our company.

We shall achieve this by continual improvement
of processes, products, services and systems,
designed to meet the expectations of the
Customers, and thereby foster
good partnerships with them.



We are approved vendors for:

- | | |
|---|----------------------------|
| 1) ABB LIMITED | 2) AREVA T & D (INDIA) LTD |
| 3) ALSTOM PROJECTS INDIA LIMITED | 4) BHARAT EARTH MOVERS LTD |
| 5) BHARAT HEAVY ELECTRICALS LTD | 6) BLUE STAR LTD |
| 7) C-DOT | 8) CESC LTD |
| 9) CUMMINS GENERATOR TECHNOLOGIES | 10) CENTRAL RAILWAY |
| 11) CROMPTON GREAVES LTD | 12) EXIDE INDUSTRIES LTD |
| 13) EMERSON NETWORK POWER (I) PVT. LTD. | 14) HIND RECTIFIERS LTD |
| 15) ITI LTD | 16) LARSEN & TOUBRO LTD |
| 17) NTPC LTD | 18) NALCO |
| 19) OTIS ELEVATOR CO (INDIA) LTD | 20) POWERICA LTD |
| 21) RELIANCE INDUSTRIES LTD | 22) SCHNEIDER ELECTRIC |
| 23) SIEMENS LTD | 24) TORRENT POWER LIMITED |
| 25) TYCO ELECTRONICS CORP INDIA PVT LTD | |



The Crimping people... since 1960

billets ELEKTRO WERKE LTD.

42, 1st Floor, Jagat Satguru Indl. Estate,
Off Aarey Road, Goregaon (E),
Mumbai - 400 063. India.

Tel.: +91-22-4058 4200

Fax: +91-22-4058 4222 / 2878 7072

E-Mail: sales@bewl.in, exports@bewl.in

Web: www.bewl.in

Dealer / Distributor

CRIMPING TOOLS AND TERMINALS

An ISO 9001 / 2008 Company

Copy right & Trade Mark registered
Note: Product Dimensions & Quantity packing standard can change without prior notice.

PUB. No.: 01/2010